

DSS-15020L

Indium Antimonide Solid State Detector

ELEMENTAL ANALYSIS
FLUORESCENCE
GRATINGS & OEM SPECTROMETERS
OPTICAL COMPONENTS
CUSTOM SOLUTIONS
PARTICLE CHARACTERIZATION
RAMAN / AFM-RAMAN / TERS
SPECTROSCOPIC ELLIPSOMETRY
SPR IMAGING

An indium antimonide photodiode, available with liquid nitrogen cooling, provides good spectral response in the mid-IR.

If you need a single point detector to measure signals in the mid-IR spectral region, the solid state InSb detector HORIBA Scientific is an excellent choice. With high sensitivity (D^*) and thermoelectric cooling, responsivity extends from 1000 nm to 5500 nm. This is one of a number of single point detectors available from HORIBA Scientific. Contact us for further information.

Used in conjunction with optically optimized housings, these detectors integrate seamlessly with HORIBA's extensive selection of monochromators. In addition, the SpectrAcq2 acquisition module allows for software integration with LabSpec, SynerJY, or LabVIEW. With all of the additional optical adapters available from HORIBA, a user can easily go from individual components to a complete spectroscopy solution.

Features and Benefits

- Wide spectral responsivity from 1000 nm to 5500 nm
- High sensitivity ($D^* \sim 10^{11}$)
- Down-looking liquid nitrogen detector housing

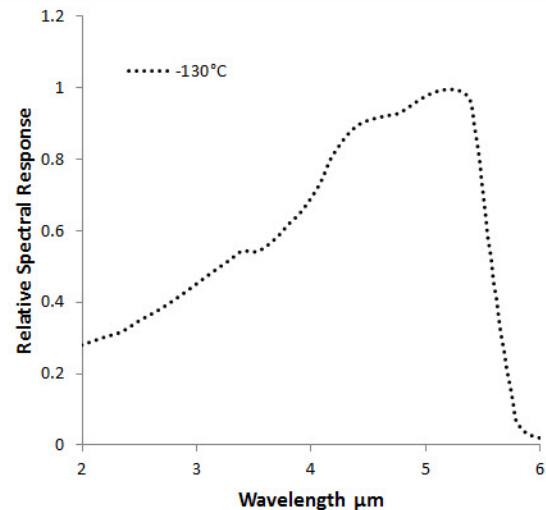

Accessories

Various accessories are available for powering the detectors, optically coupling detectors to HORIBA monochromators, and data acquisition.

- Power supply for LN2 detectors, DSS-15VP
- Mirror-based housing, 1427C
- BNC cable, J30646
- SpectrAcq2 data acquisition module
- SMA fiber adapter, DSS-SMA
- Dual 1427C housing adapter, J23078370
- Dual detector housing, J23079050
- BNC switchbox for dual detectors, SWB-AB

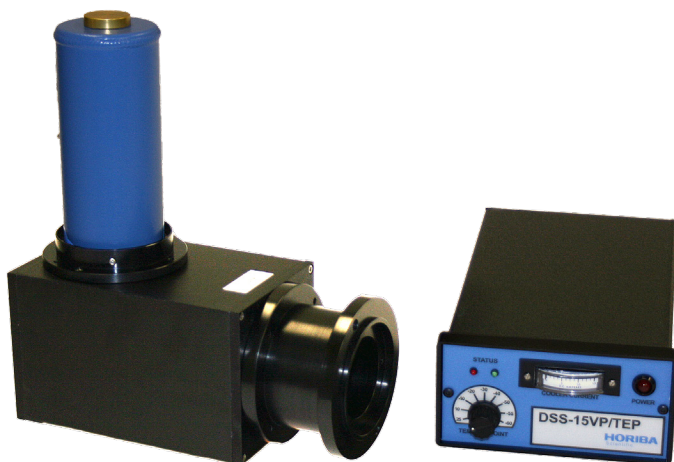

Specifications

Part number	DSS-IS020L
Detector type	2.0 mm diameter indium antimonide photodiode
Operating temperature (°C)	-130°C Liquid Nitrogen Cooled
Operating wavelength (µm)	1.0 – 5.5 µm
Responsivity (V/W @ peak)	10 ⁵ / 10 ⁴
Detectivity (D*)	1.2 x 10 ¹¹
Bandwidth (-3dB – Hz, typical)	DC – 2.5 kHz
Power requirements	± 9 VDC to ± 15 VDC
Connections	BNC signal output. Shielded power cable terminated with a DB-9 connector directly couples the unit with the PS/TC-1 Low Noise Power Supply / Controller.

Mechanical Dimensions

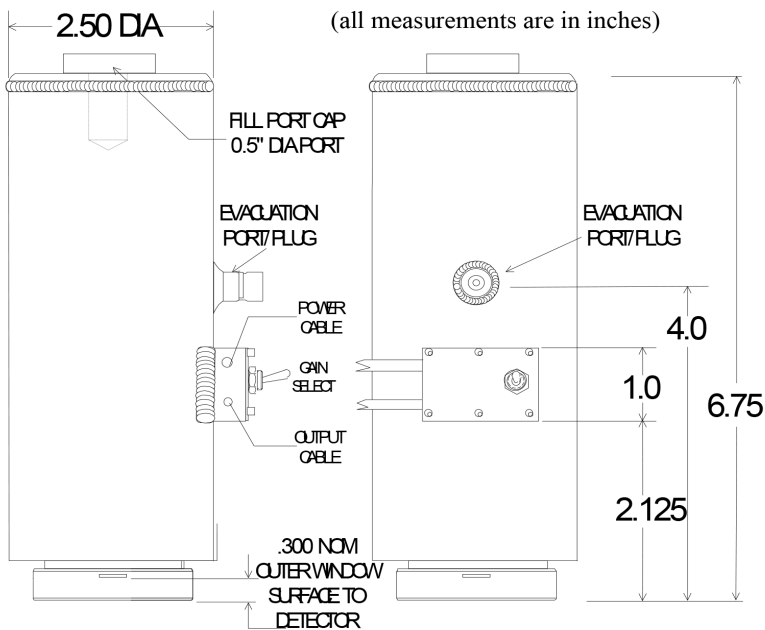

Electrical Diagram

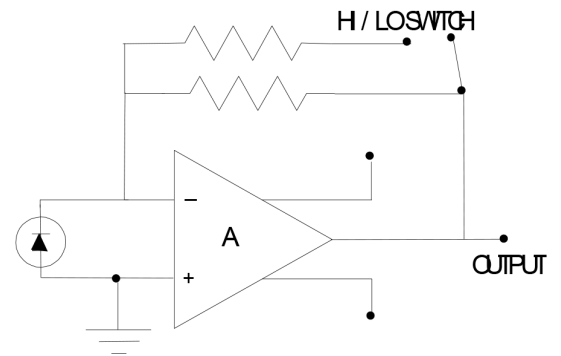

DB-9 Pin Out Diagram

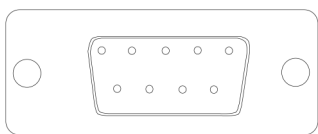

- | | |
|---------------|-------------|
| 1. No connect | 6. +V |
| 2. No connect | 7. -V |
| 3. No connect | 8. GND |
| 4. No connect | 9. Case GND |
| 5. No connect | |

info.sci@horiba.com

www.horiba.com/osd

HORIBA
Scientific

USA: +1 732 494 8660
UK: +44 (0)1604 542 500
China: +86 (0)21 6289 6060
Taiwan: +886 3 5600606

France: +33 (0)1 69 74 72 00
Italy: +39 06 51 59 22 1
India: +91 80 41273637
Brazil: +55 (0)11 2923 5400

Germany: +49 (0) 6251 8475 0
Japan: +81(75)313-8121
Singapore: +65 (0)6 745 8300
Other: +33 (0)1 69 74 72 00