

PoliSpectra[®] M116 MultiTrack Spectrometer

8-16-32 Simultaneous UV-NIR Spectra

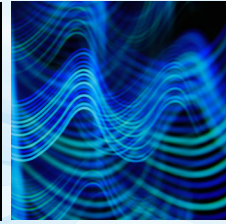
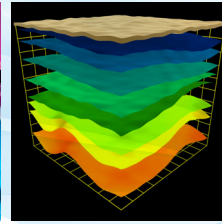
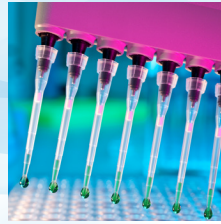
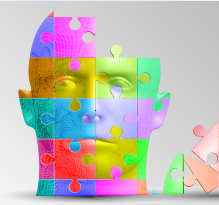

For OEM
Industrial Applications

PoliSpectra® MultiTrack Fiber Spectrometers

8-16-32 Simultaneous UV-NIR Spectra

Overview

HORIBA designs and manufactures a large range of custom OEM fiber-coupled, multi-spectra spectrometers capable of simultaneous measurement of up to 32 fiber channels and sequential measurement up to 96. Utilizing a concentric imaging spectrometer with a broadband spectral range and a customized fiber bundle, the HORIBA OEM multifiber spectrometers provide excellent imaging quality with minimum crosstalk.

The PoliSpectra® MultiTrack systems feature high throughput/sensitivity and a 2D Scientific back-illuminated CMOS sensor which can be configured with 8, 16 or 32 fiber input channels for simultaneous acquisition of UV-NIR spectra.

With an optional nitrogen purge, the system can be configured for low UV coverage. Additionally the high QE sCMOS sensor and an integrated order sorting filter allow wavelength coverage beyond 1 μm .

Applications

- MultiTrack Spectroscopy
- Fluorescence, Emission and Reflectance

Some examples from semiconductor applications to life sciences:

- Quality Control
- Light Source Calibration Monitoring
- Plasma Monitoring
- Blood/DNA Multisampling

Optical and Mechanical Layout

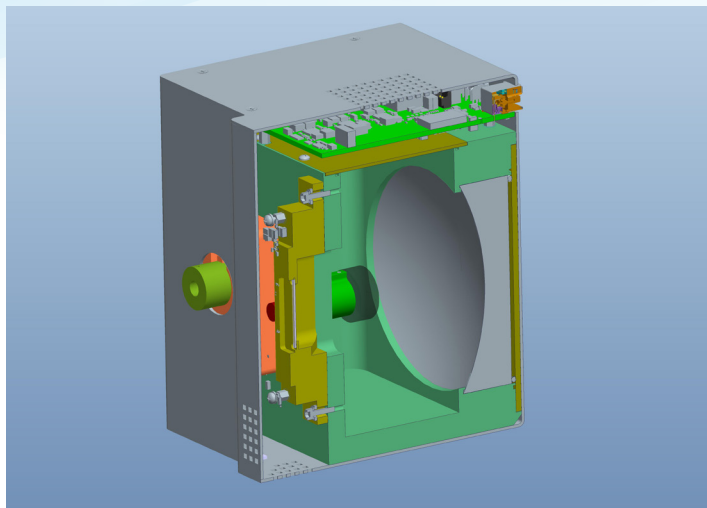

Concentric spectrometer's layout providing excellent spatial imaging.

Features

Simultaneous measurement up to 32 fiber channels with minimal crosstalk

Extended UV capability below 200 nm

High spectral and spatial resolution combined with high throughput

High speed and low noise sCMOS 2048 pixel sensor

On-board processing capability using powerful dual-core ARM cortex and 2 GB memory

USB 3 interface

Stable and robust

8-channel Spectrometer Specifications*

Spectral Coverage	185 - 1050 nm (extension to low UV with N2 purge) Tunable at factory between these ranges: 185-920 nm and 280-1050 nm
Spectrometer Input	8 channel, $\phi 200 \mu\text{m}$ core fibers with $\phi 220 \mu\text{m}$ clad, separated by a $\phi 220 \mu\text{m}$ dead fiber
Spectral Resolution	1.25 nm typical (22 μm slit width) and up, depending on the slit size
Spectral Dispersion	34.6 nm/mm; 0.38 nm/pixel
Crosstalk** (Adjacent Channel)	< 0.1% (measured @ 600 nm)
Crosstalk (Non-adjacent Channel)	< 0.1% (measured @ 600 nm)
Focal Length	116 mm
F/#	F/2.3
Smile and Keystone	1.5 pixel (typical)
Stray Light***	< 0.1% (typical)
Wavelength Accuracy	0.1 nm (using 8 channel wavelength calibration)
Software	LabVIEW™ acquisition software for initial evaluation (DLLs provided for software integration)

16-channel and 32-channel Spectrometer Specifications

Spectral Coverage	185 - 1050 nm (configurable based on customer's need)
Spectrometer Input	16 channel, $\phi 100 \mu\text{m}$ core fibers with $\phi 110 \mu\text{m}$ clad 32 channel, $\phi 70 \mu\text{m}$ core fibers with $\phi 77 \mu\text{m}$ clad
Spectral Resolution	1 nm and up, depending on fiber core size
Spectral Dispersion	34.6 nm/mm; 0.38 nm/pixel
F/#	F/2.3
Smile and Keystone	1.5 pixel (typical)
Stray Light	< 0.1% (typical)
Wavelength Accuracy	0.1 nm (using 32 channel wavelength calibration)

Specifications for Scientific Back-Illuminated CMOS Image Sensor with High Speed Electronics

Detector Model	sCMOS BI sensor with electronic rolling shutter (all the parameters are specified at normal room temperature of 25° C unless otherwise noted)	
Sensor Format****	2048 x 512	
CMOS Pixel Size	11 μm x 11 μm	
CMOS Height	5.6 mm	
CMOS QE	The peak QE is 77% at 250 nm and 95% at 560 nm (refer to graphs below)	
Sensor Temperature	Uncooled	
Frame Rate	94 fps (HDR mode), 188 fps (STD mode) on 2D sCMOS sensor	
Full Well	80 ke ⁻ typical (HDR mode)	
Communication	USB 3	
Readout Noise	1.6 e ⁻ typical, 2.0 e ⁻ maximum	
Digitization	16-bit (HDR mode), 12-bit (High Sensitivity mode)	
Dynamic Range	93.9 dB typical in HDR mode	
Non-linearity (measured on each system)	1.8% (maximum) in HDR mode	<0.9% (maximum) in High Sensitivity mode
Environmental Conditions	Operating temperature 15° C to 40° C ambient; Relative humidity < 70% (non-condensing); Storage temperature -25° C to 45° C	
Power requirements AC/DC power supply (provided)	90-264 VAC, 47-63 Hz	

* Specifications, form factor, and spectrometer cover subject to change without notice. No LabVIEW license is needed to run our acquisition software.

** Crosstalk (to adjacent channels): the % of signal leaking to the adjacent channels while one channel is on and others are off.

*** Stray light using BP Filter: Baseline light level, outside the band, divided by BP peak (unsaturated) value.

**** [See sensor manufacturer's Blemish / Defect information](#)

Features

Scientific CMOS Back-Illuminated Sensor Quantum Efficiency

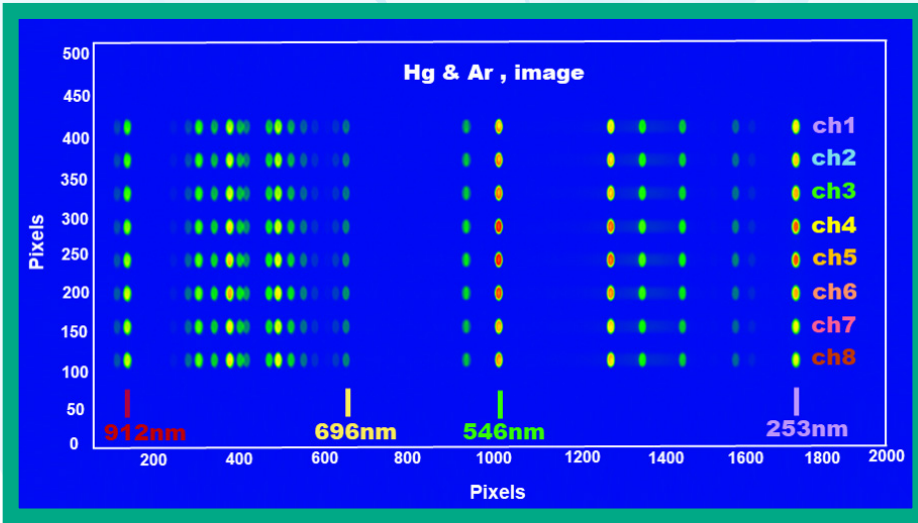
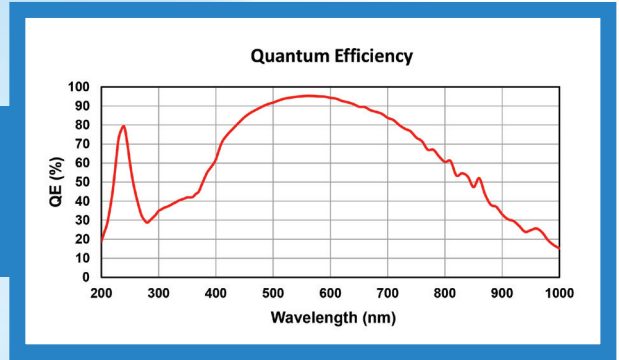
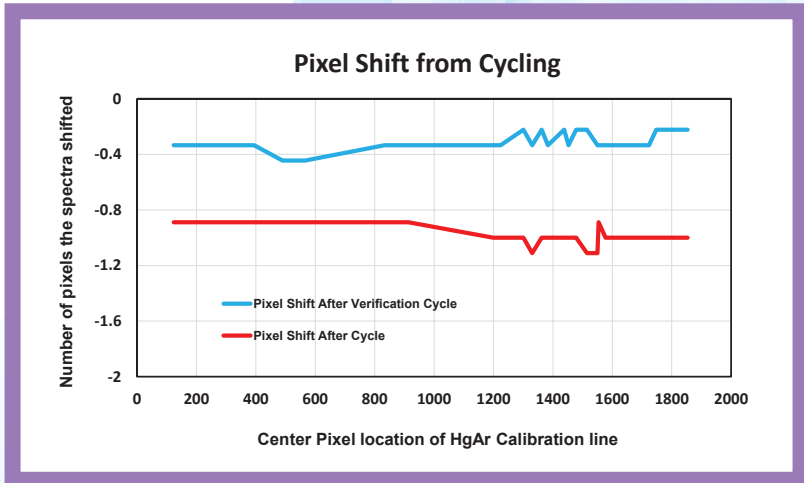
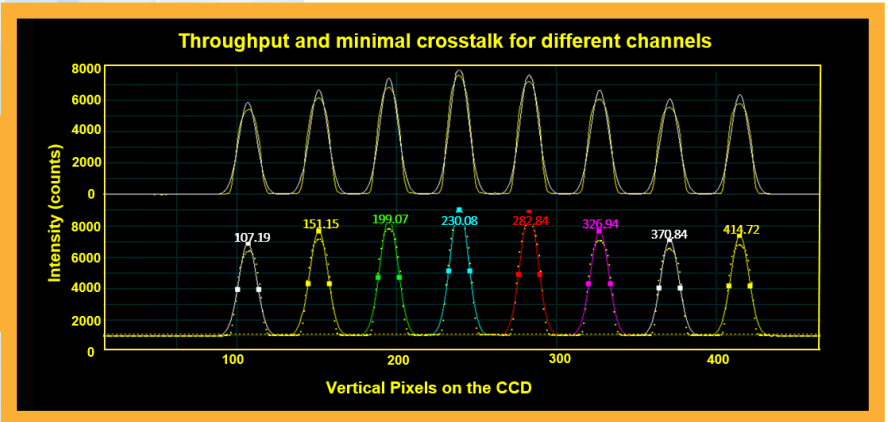

Image of 8-channel Fiber Bundle Illuminated with Hg and Ar Lamp

Throughput Differences and Crosstalk between Input Fiber Channels



Thermal stability study cycling from -20°C to 50°C

Hyperspectral Imaging Distortions: Keystone and Smile

Definitions:

The **KEYSTONE** property is a band-to-band magnification that changes with wavelength. This involves mixing of spectra from adjacent field positions.

The **SMILE** property is a wavelength shift caused by a change in dispersion with field position [1].

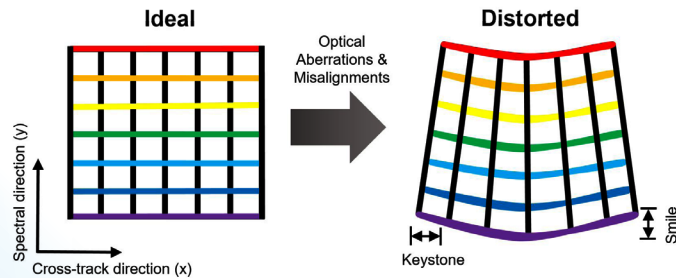

Schematic showing an ideal image compared to a real image with optical distortions [2]

L_{λ} = Pixel center location of each Field Identifier slit at a given wavelength

$$\text{Keystone} = (L_{\lambda_{\max}} - L_{\lambda_{\min}})$$

C_{λ} = Center pixel location of a given wavelength at each Field Identifier location

$$\text{Smile} = (C_{\lambda_{\max}} - C_{\lambda_{\min}})$$

KEYSTONE is measured by calculating the maximum displacement a field slit makes as it moves across the entire spectrum, and the **SMILE** is measured by calculating the maximum displacement a wavelength makes as it moves across the entire height of the region of interest.

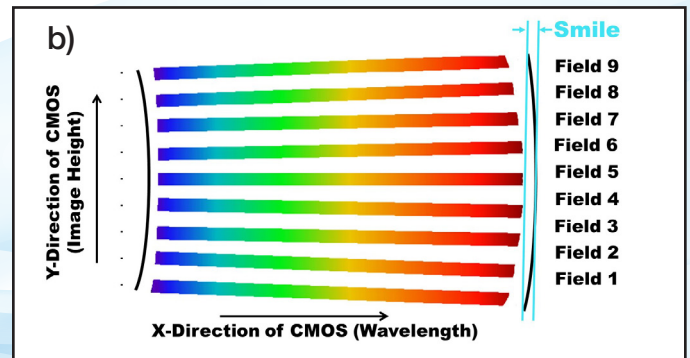
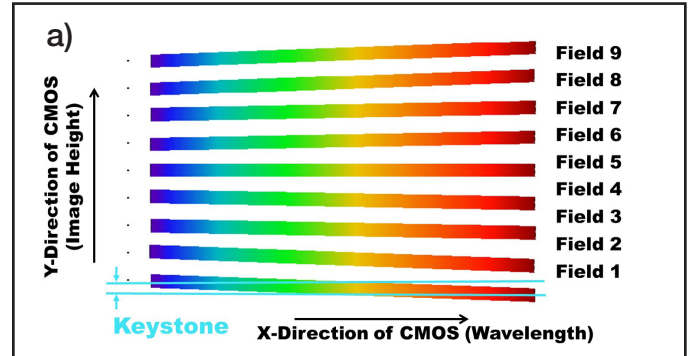

The method HORIBA uses to measure a) Keystone and b) Smile

Excellent optical performance for PoliSpectra MultiTrack system showing keystone and smile smaller than 1.5 pixels

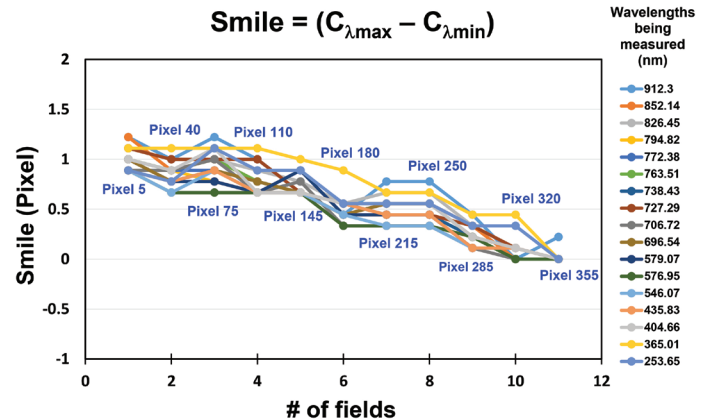
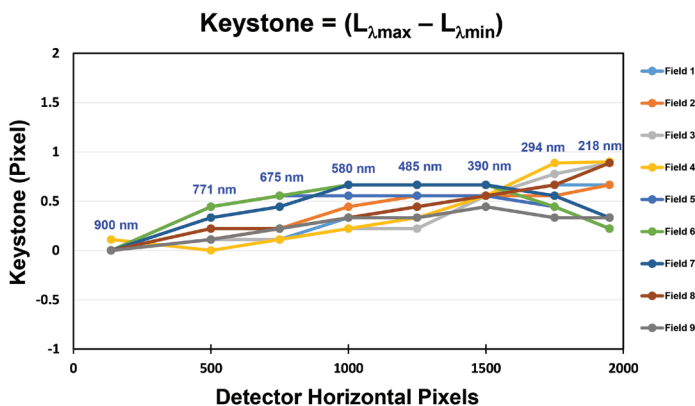

An example of the production testing for HORIBA's hyperspectral/multichannel spectroscopy systems based on the method described above.

[1] J. Fischer, M. Baumbach, J. Bowles, J. Grossmann, and J. Antoniadis, "Comparison of low-cost hyperspectral sensors," Proc SPIE, Vol. 3438, pp. 23-30, 1998.

[2] N. Yokoya, N. Miyamura, and A. Iwasaki, "Detection and correction of spectral and spatial misregistrations for hyperspectral data using phase correlation method," Applied Optics, vol. 49, no. 24, pp.4568-4575, 2010.

System Mechanical Drawings

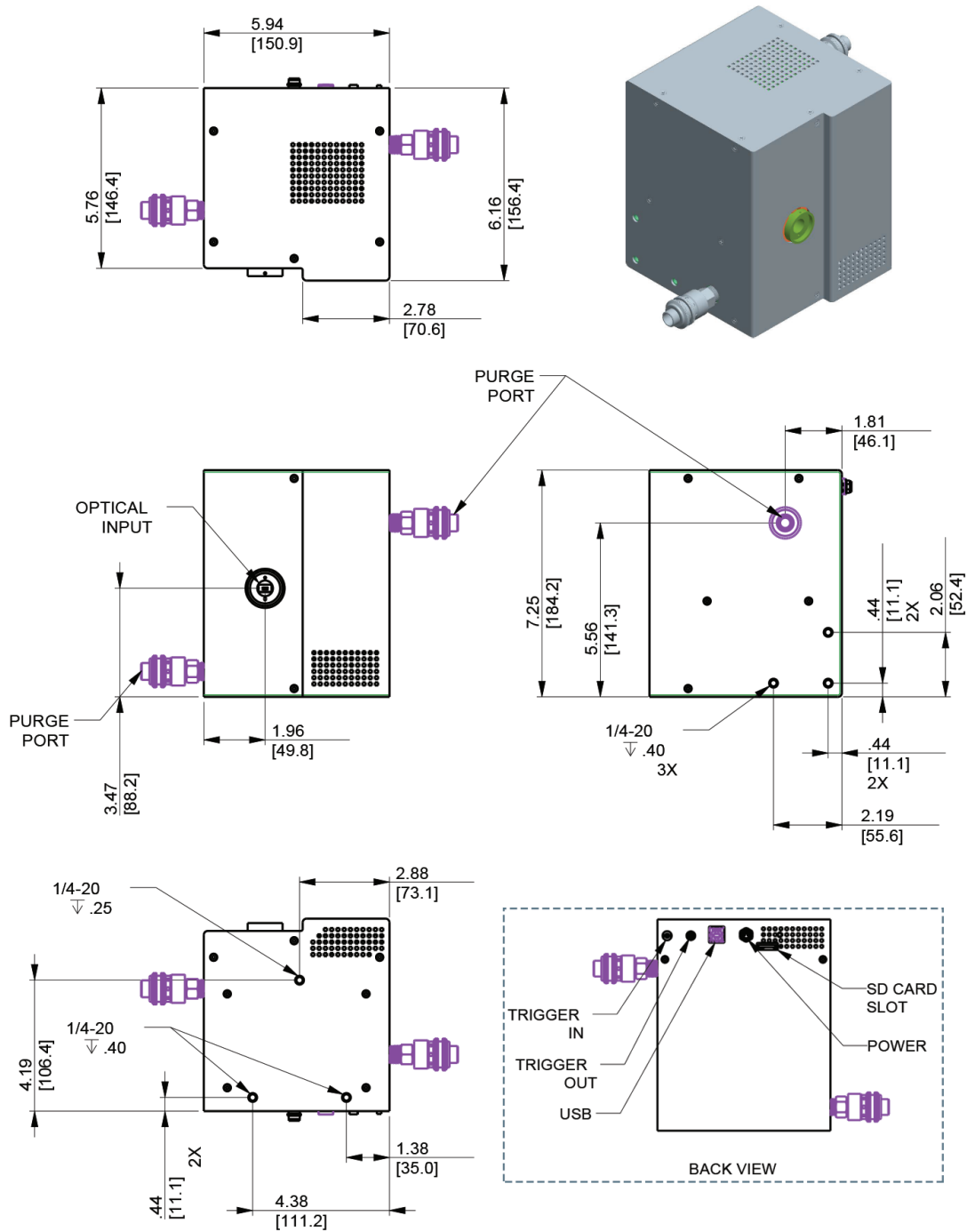

Customer can specify any number of fiber channels (between 4 and 32) for simultaneous measurement. Fiber bundle type and length can be customized.

Best Selling Miniature Spectrometers for OEM Industrial Applications

Fiber-coupled USB Spectrometers:

MiniVS20 Spectrometer with Linear UV-VIS CMOS or NIR InGaAs Sensor

5 nm resolution

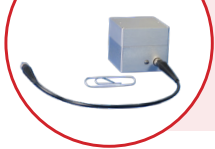

OEM hand-held spectrometer covering 190 to 1,700 nm for various low stray light applications

- Aberration-corrected concave holographic grating options
- VIS configuration featuring a 1.7" x 1.9" x 2" size combined with full F/2.3 optics for high signal-to-noise
- High throughput, compactness and long term reliability

MiniVS70 VIS Spectrometer with FI CMOS or BI CCD

1 nm resolution



NEW miniaturized VS70 configuration

- Based on high performance aberration-corrected concave gratings fitted with a custom order-sorting filter to eliminate higher orders
- Low cost combined with high performance and low stray light
- Long term opto-mechanical stability and choice of front-illuminated linear CMOS or back-illuminated CCD sensors

VS70 UV-VIS-NIR Spectrometer with Uncooled / TE-cooled CCD

1-2 nm resolution



Compact, versatile most popular VS70 OEM spectrometer and OES configurations

- Based on high performance aberration-corrected concave gratings with full F/2.3 aperture
- Affordable, high throughput, robust and stable
- Electronics drivers ranging from **USB-2 to Ethernet and EtherCAT**

CiCi-Raman-NIR with Scientific Camera Optimized for 785 nm

6 cm⁻¹ resolution

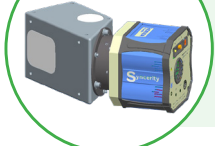

Most compact OEM Raman spectrometer with aberration-corrected holographic grating

- Covers 150-3,300 cm⁻¹
- High efficiency and low stray light
- Available in F/2.3 and in compact F/5 configurations
- -50° C deep-cooled scientific CCD camera with minimized etaloning and high NIR QE

PoliSpectra® Quad Spectrometer for Simultaneous Acquisition of 4 VIS Spectra

1 nm resolution



CCD spectrometer for simultaneous acquisition from 4 fiber inputs (470-730 nm)

- High-speed electronics (as fast as <1.5 msec readout time for 4 spectra)
- QUAD-channel high throughput system (f/2.3) and ultra-low stray light
- Industrial low-light applications from low light fluorescence to reflectance

PoliSpectra® M116 8-32 Channel MultiTrack UV-VIS-NIR CMOS Spectrometer

1 nm resolution



Fiber-coupled multi-spectra system with 8- to 32-channel simultaneous measurements

- Concentric optical design with UV extended spectral range provides minimized crosstalk
- High throughput USB-3 system featuring a fast 2D scientific BI CMOS running at 94 to 188 frames per second, acquiring 8, 16 or 32 simultaneous spectra (2048 pixels per spectrum)

PoliSpectra® H116 Imaging Spectrometer for Hyperspectral Work from UV to NIR

Free-space coupled
1 nm & 40 μm resolution



Ultra-high performance rugged spectrometer for hyperspectral imaging with a 2D sCMOS Camera

- For line-image scanning, in a push-broom hyperspectral configuration
- High throughput, USB-3 system featuring a fast 2D scientific BI CMOS with rolling shutter, running at 94 (HDR) to 188 (Standard Mode) frames per second (2048 pixels per spectrum)

OEM Spectrometer Selection Guide

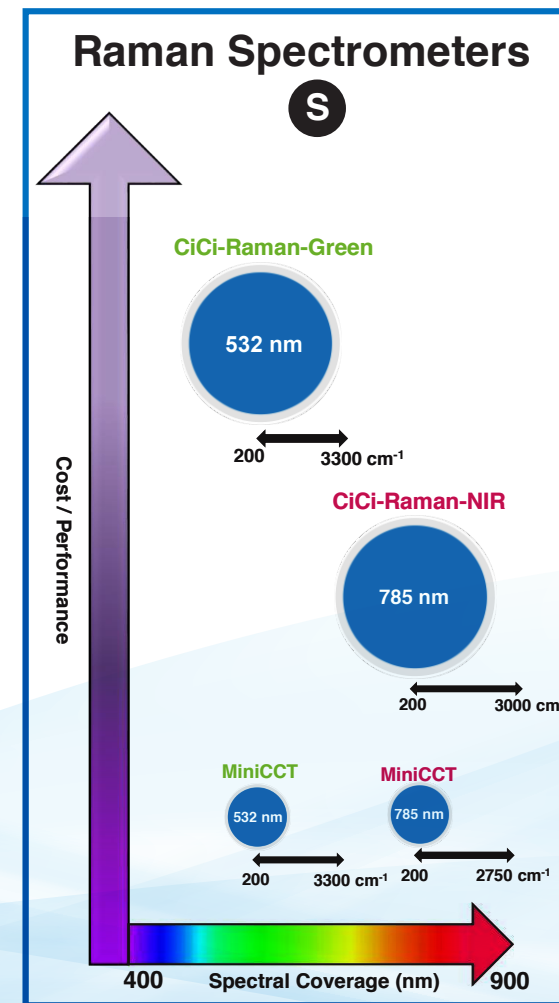
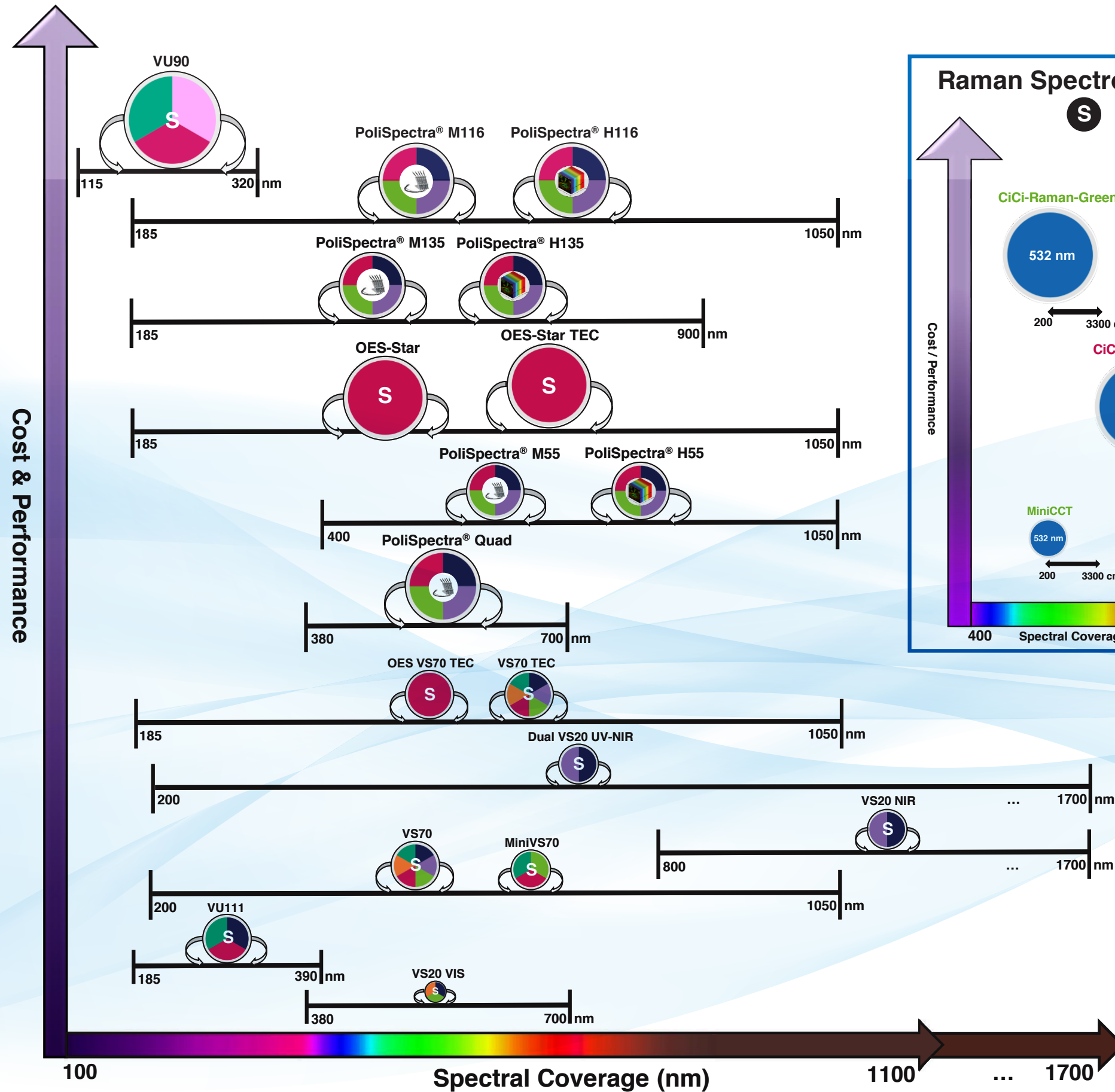

Legend

Spectrometer Input Type

- S** Single-fiber Input
- Multi-fiber Input
- Hyperspectral Imager

Technique & Application

- Emission (OES)
- Absorbance
- Fluorescence
- Reflectance
- Raman
- Metrology
- Photoluminescence
- Colorimetry

Spectrometer Size

- ≤ 10.5x9x7 inches
- ≤ 8x8x8 inches
- ≤ 7.5x4.5x5 inches
- ≤ 7.5x4.5x3 inches
- ≤ 6x6x7.5 inches
- ≤ 5x5x5 inches
- ≤ 5x5x2 inches
- ≤ 2x2x2 inches

OEM Philosophy and Mission

3 Centers of Excellence Dedicated to OEM Spectroscopy and Camera Solutions in US, EU, and Asia

Our mission is to provide a complete development and manufacturing experience, from optical simulations to opto-mechanical design and prototyping of spectroscopic and camera systems extending to, and including, electronics, firmware, software design and first articles.

Our products provide superior performance, reliability and stability, combined with robust cost reduction. Capable of flexible high volume production capacity in quantities of hundreds to thousands per year, we offer full confidentiality providing "Black Boxes" or private labelling, using your logo or graphics.

Unmatched customer service is provided by our exceptionally experienced workforce featuring on-time delivery and flexibility, allowing scheduling modifications.

Adhering to Copy Exactly! (CE!) processes, our fully trained staff, from engineering to manufacturing, form a dedicated OEM engineering force that supports you over the lifetime of the product.

Scientific Segment - OEM Products and Capabilities:

- Custom master optical diffraction gratings
- Diffraction grating replicas (concave, convex and flat)
- Spectrometers, optical assemblies with pre-aligned sensors (CCD, PDA, CMOS, InGaAs) using either customers' or HORIBA's OEM electronics
- OES spectrometers
- Spectroscopy systems or modular engines, such as mini fluorometers and mini Raman systems
- Single and double scanning monochromators
- Imaging spectrographs and spectrometers with CCD or CMOS cameras
- Multispectra spectrometers with multiple fiber inputs / MultiTrack spectroscopy
- Hyperspectral system with HORIBA or customer provided camera (Push-broom configurations)
- Cameras: Spectroscopic deep-cooled scientific cameras (1D and 2D CCD & InGaAs – FI and BI)
- OEM electronics for optosensors ranging from PD and PDA to CCD and CMOS sensors
- Imaging cameras: Uncooled and cooled with FI and BI high-end scientific CMOS
- VUV/FUV spectrometers and CCD vacuum and N2-purged cameras

Scientific Deep Cooled CCD, InGaAs and CMOS Cameras



	USA & Canada	Japan	Europe & Asia
	OEM.US@horiba.com	OEM.JAPAN@horiba.com	OEMSALES.JYFR@horiba.com
	+1 732 494 8660 Ext. 7733	+81 (75) 313 8121	+33 (0) 1 69 74 72 00