

PoliSpectra[®] H116

Imaging Spectrometer for Hyperspectral Applications

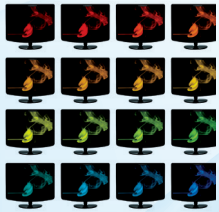
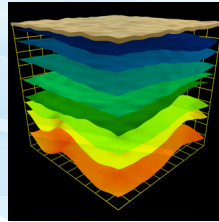
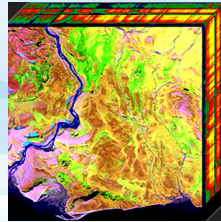
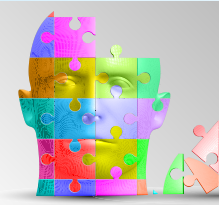

For OEM
Industrial Applications

PoliSpectra[®] H1 16 Spectrometers

Imaging Spectrometer for Hyperspectral Applications

Overview

HORIBA has developed a high performance rugged hyperspectral imaging spectrometer with an integrated 2D scientific CMOS camera. The elegant all-concentric design combines high spatial and spectral resolution using a type-I holographic diffraction grating and mirror. This system can be used as a line-scanning instrument (push-broom) that collects full spectral data simultaneously, across the input slit height at up to 188 frames per second.

Applications

- Quality Control Inspection
- Process Monitoring
- Remote Aerial Sensing
- Advanced Machine Vision
- Environmental monitoring
- Food & Beverage Inspection
- Recycling

Optical and Mechanical Layout

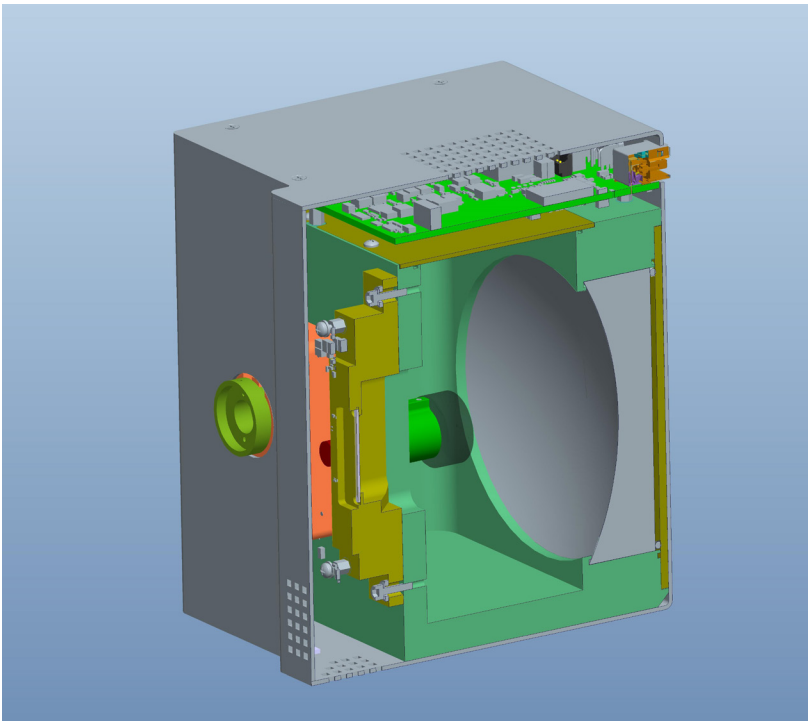

Concentric spectrometer's layout providing excellent spatial imaging.

Features

**Superb imaging quality
due to high spectral and
spatial resolution at F/2.3**

**Frame rates
as fast as 188 fps**

**High throughput
combined with low
stray light performance**

**2D scientific CMOS
with high quantum
efficiency and low noise**

**On-board processing
capability using powerful
dual-core ARM cortex
and 2 GB memory**

**Broad wavelength
coverage from
185 nm to 1050 nm**

Stable and robust

General Spectrometer Specifications*

Spectral Coverage	185–1050 nm Tunable at factory between these ranges: 185-920 nm and 280-1050 nm
Spectral Resolution	1.25 nm typical (22 μm slit width) and up, depending on the slit size
Spatial Resolution	50 μm typical
Spectral Dispersion	34.6 nm/mm; 0.38 nm/pixel
Focal Length	116 mm
F/#	F/2.3
Smile and Keystone	1.5 pixel (typical)
Stray Light**	< 0.1% (typical)
Wavelength Accuracy	0.1 nm (using multi-area wavelength calibration)
Software	LabVIEW™ acquisition software for initial evaluation (DLLs provided for software integration)

Specifications for Scientific Back-Illuminated CMOS Image Sensor with High Speed Electronics

Detector Model	sCMOS BI sensor with electronic rolling shutter. (All the parameters are specified at normal room temperature of 25° C unless otherwise noted.)	
Sensor Format***	2048 x 512	
CMOS Pixel Size	11 μm x 11 μm	
CMOS Height	5.6 mm	
CMOS QE	The peak QE is 77% at 250 nm and 95% at 560 nm (refer to graphs below)	
Sensor Temperature	Uncooled	
Frame Rate	94 fps (HDR mode), 188 fps (STD mode) on 2D sCMOS sensor	
Full Well	80 ke ⁻ typical (HDR mode)	
Readout Noise	1.6 e ⁻ typical, 2.0 e ⁻ maximum	
Digitization	16-bit (HDR mode), 12-bit (High Sensitivity mode)	
Dynamic Range	93.9 dB typical in HDR mode	
Non-linearity (measured on each system)	1.8% (maximum) in HDR mode	<0.9% (maximum) in High Sensitivity mode
Communication	USB 3	
Environmental Conditions	Operating temperature 15° C to 40° C ambient; Relative humidity <70% (non-condensing); Storage temperature -25° C to 45° C	
Power requirements AC/DC Power Supply (provided)	90-264 VAC, 47–63 Hz	

* Specifications, form factor, and spectrometer cover subject to change without notice. No LabVIEW license is needed to run our acquisition software.

** Stray light using BP Filter: Baseline light level, outside the band, divided by BP peak (unsaturated) value.

*** [See sensor manufacturer's Blemish / Defect information](#)

Scientific CMOS Back-Illuminated Sensor Quantum Efficiency

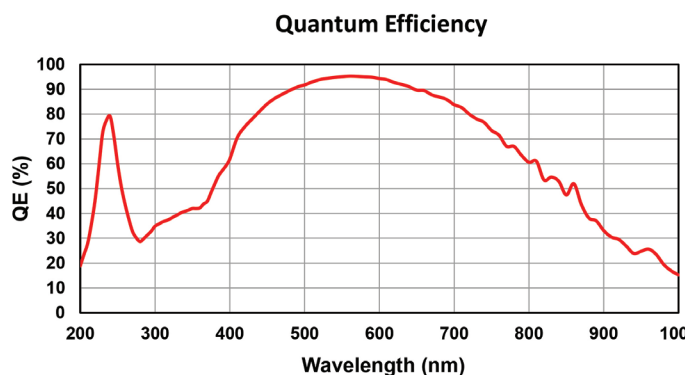

Features

Push Broom Hyperspectral Imaging Configuration

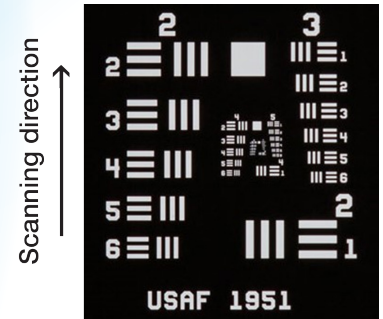
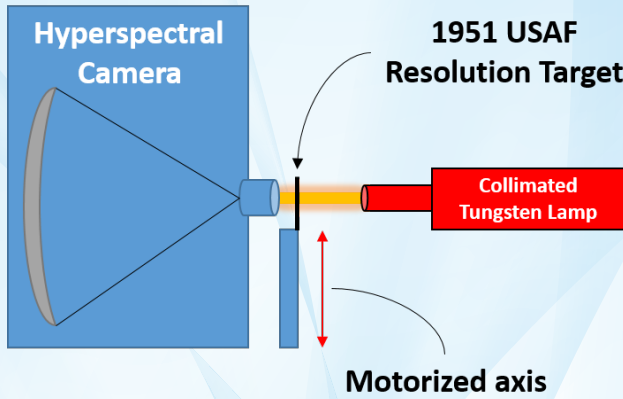

USAF 1951 transmission resolution target.

Resolution test configuration using the H116 hyperspectral camera and a 1951 USAF transmission resolution target via the push broom method. A lens focuses the image on the slit, which is oriented horizontally. A motorized stage moves the target vertically to assemble the hyperspectral cube. A collimated tungsten light provides illumination.

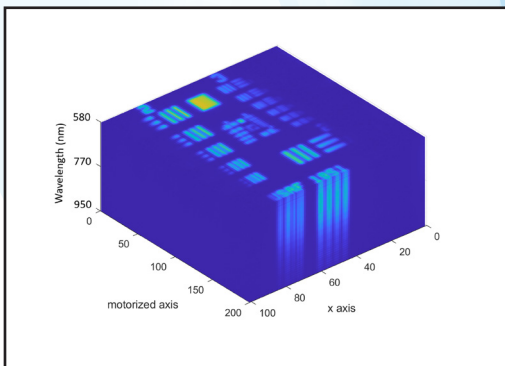

A hyperspectral cube of the 1951 USAF target stitched together from 200 images illuminated by a tungsten lamp. The hyperspectral camera acquired this image in XZ-plane slices (corresponding to real space horizontal axis and wavelength, respectively) and assembled the hyperspectral cube by stitching XZ images along the y-axis (the motorized scan axis). The intensity at each point is in units of electron counts.

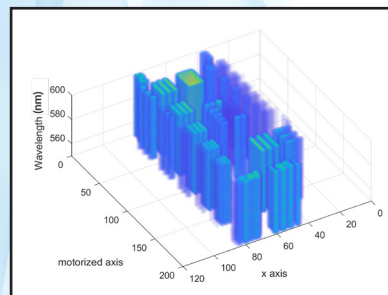
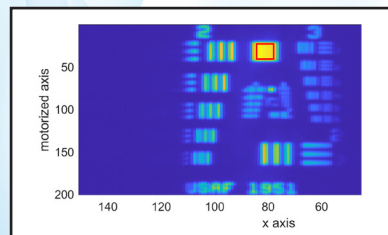

A hyperspectral cube with the background subtracted

(Left) A slice of the hyperspectral cube showing the 1951 USAF resolution target at 808 nm. Pixels from the sliced hyperspectral cube were spatially averaged (within the red box at left) to produce a spectrum for that area (shown below). No sample transmission below 400 nm.

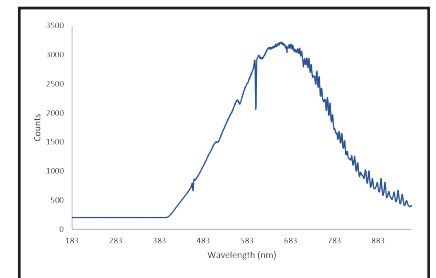

Over the last 25 years, HORIBA has been a pioneer in the field of holographic gratings and imaging spectrographs, and has been awarded many patents.

Our first patent on an Offner design, coupled with a CCD and multiple fibers at the input, was filed in 1989, and published in 1992.

Examples of key patents:

- 1971: First aberration-corrected grating
- 1972: Concave grating spectrograph with flat field
- 1989: Aberration-corrected grating in a Czerny-Turner spectrometer
- 1992: Concentric (Offner) spectrograph with holographic grating and 2D detector
- 1999: Concentric (Dyson) spectrograph
- 2010: Spectrometer with astigmatism correction
- 2011: Concentric (Dyson) spectrograph with improved image quality.

he PoliSpectra H116 and M116 use a new proprietary concentric layout combined with a Type-I holographic grating. Such Type-I gratings feature equidistant and parallel grooves, and are optimized for very broad spectral range.

Hyperspectral Imaging Distortions: Keystone and Smile

Definitions:

The **KEYSTONE** property is a band-to-band magnification that changes with wavelength. This involves mixing of spectra from adjacent field positions.

The **SMILE** property is a wavelength shift caused by a change in dispersion with field position [1].

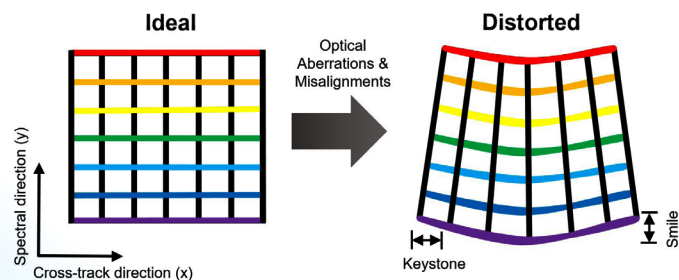

Schematic showing an ideal image compared to a real image with optical distortions [2]

L_{λ} = Pixel center location of each Field Identifier slit at a given wavelength

$$\text{Keystone} = (L_{\lambda_{\max}} - L_{\lambda_{\min}})$$

C_{λ} = Center pixel location of a given wavelength at each Field Identifier location

$$\text{Smile} = (C_{\lambda_{\max}} - C_{\lambda_{\min}})$$

KEYSTONE is measured by calculating the maximum displacement a field slit makes as it moves across the entire spectrum and the **SMILE** is measured by calculating the maximum displacement a wavelength makes as it moves across the entire height of the region of interest.

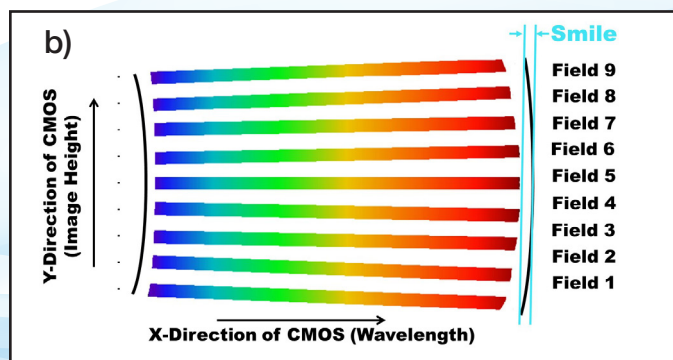
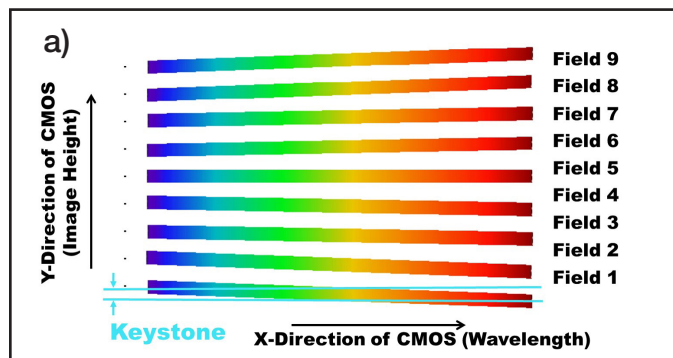

The method HORIBA uses to measure a) Keystone and b) Smile

Excellent optical performance for PoliSpectra system showing keystone and smile smaller than 1.5 pixels

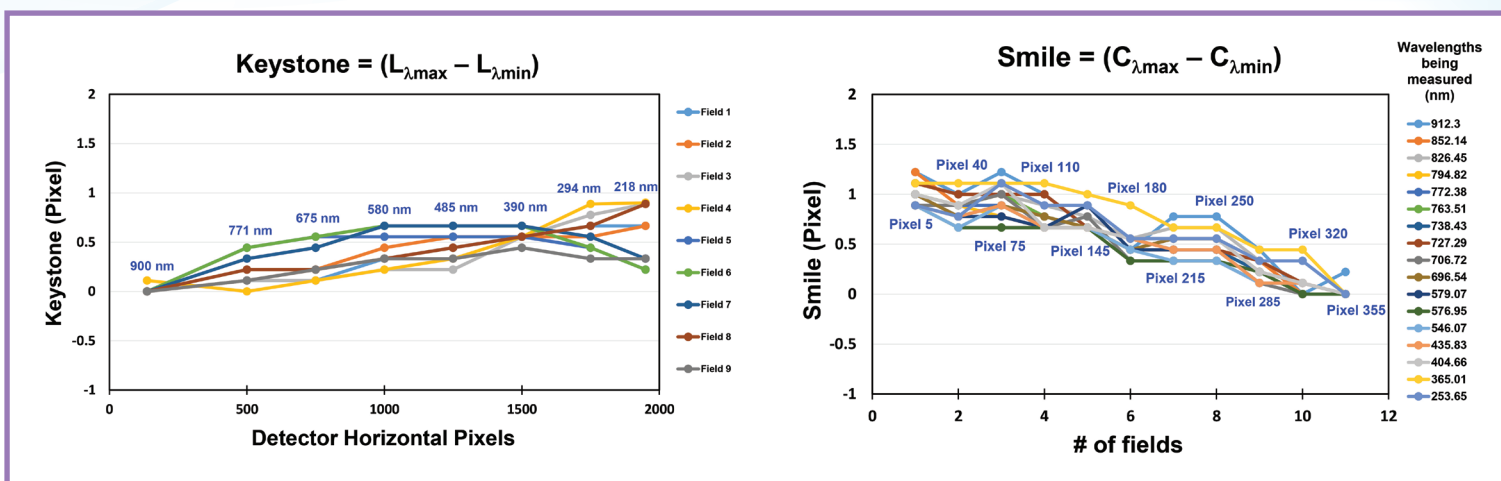

An example of the production testing for HORIBA's hyperspectral/multichannel spectroscopy systems based on the method described above.

[1] J. Fischer, M. Baumbach, J. Bowles, J. Grossmann, and J. Antoniadis, "Comparison of low-cost hyperspectral sensors," Proc SPIE, Vol. 3438, pp. 23-30, 1998.

[2] N. Yokoya, N. Miyamura, and A. Iwasaki, "Detection and correction of spectral and spatial misregistrations for hyperspectral data using phase correlation method," Applied Optics, vol. 49, no. 24, pp.4568-4575, 2010.

System Mechanical Drawings

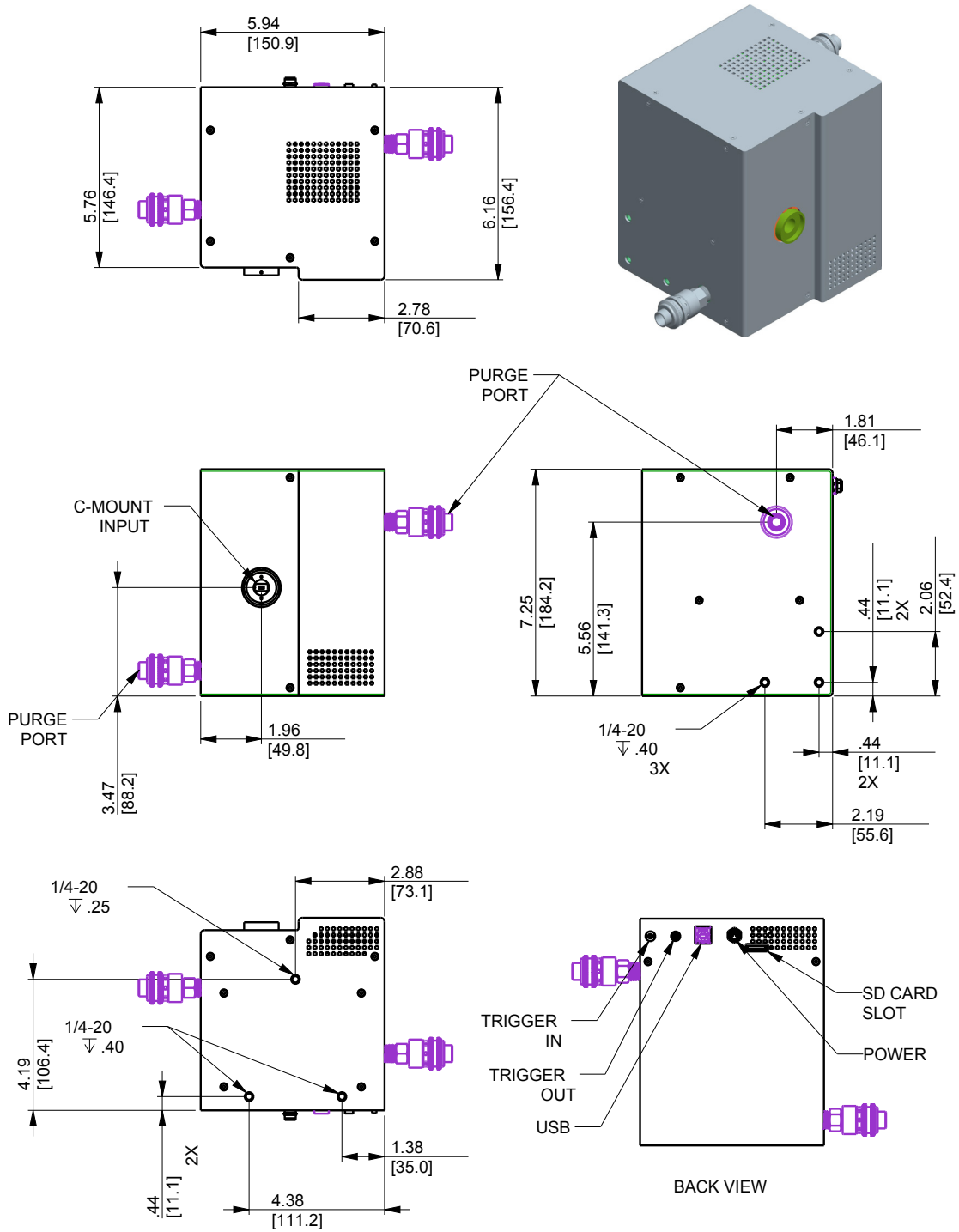

Customer's provided optics are required to image onto the 22 μm x 5632 μm spectrometer slit.

Best Selling Miniature Spectrometers for OEM Industrial Applications

Fiber-coupled USB Spectrometers:

MiniVS20 Spectrometer with Linear UV-VIS CMOS or NIR InGaAs Sensor

5 nm resolution

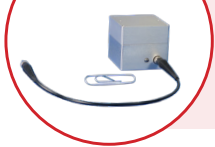

OEM hand-held spectrometer covering 190 to 1,700 nm for various low stray light applications

- Aberration-corrected concave holographic grating options
- VIS configuration featuring a 1.7" x 1.9" x 2" size combined with full F/2.3 optics for high signal-to-noise
- High throughput, compactness and long term reliability

MiniVS70 VIS Spectrometer with FI CMOS or BI CCD

1 nm resolution



NEW miniaturized VS70 configuration

- Based on high performance aberration-corrected concave gratings fitted with a custom order-sorting filter to eliminate higher orders
- Low cost combined with high performance and low stray light
- Long term opto-mechanical stability and choice of front-illuminated linear CMOS or back-illuminated CCD sensors

VS70 UV-VIS-NIR Spectrometer with Uncooled / TE-cooled CCD

1-2 nm resolution



Compact, versatile most popular VS70 OEM spectrometer and OES configurations

- Based on high performance aberration-corrected concave gratings with full F/2.3 aperture
- Affordable, high throughput, robust and stable
- Electronics drivers ranging from **USB-2 to Ethernet and EtherCAT**

CiCi-Raman-NIR with Scientific Camera Optimized for 785 nm

6 cm⁻¹ resolution

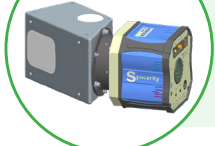

Most compact OEM Raman spectrometer with aberration-corrected holographic grating

- Covers 150-3,300 cm⁻¹
- High efficiency and low stray light
- Available in F/2.3 and in compact F/5 configurations
- -50° C deep-cooled scientific CCD camera with minimized etaloning and high NIR QE

PoliSpectra® Quad Spectrometer for Simultaneous Acquisition of 4 VIS Spectra

1 nm resolution



CCD spectrometer for simultaneous acquisition from 4 fiber inputs (470-730 nm)

- High-speed electronics (as fast as <1.5 msec readout time for 4 spectra)
- QUAD-channel high throughput system (f/2.3) and ultra-low stray light
- Industrial low-light applications from low light fluorescence to reflectance

PoliSpectra® M116 8-32 Channel MultiTrack UV-VIS-NIR CMOS Spectrometer

1 nm resolution



Fiber-coupled multi-spectra system with 8- to 32-channel simultaneous measurements

- Concentric optical design with UV extended spectral range provides minimized crosstalk
- High throughput USB-3 system featuring a fast 2D scientific BI CMOS running at 94 to 188 frames per second, acquiring 8, 16 or 32 simultaneous spectra (2048 pixels per spectrum)

PoliSpectra® H116 Imaging Spectrometer for Hyperspectral Work from UV to NIR

Free-space coupled
1 nm & 40 μm resolution



Ultra-high performance rugged spectrometer for hyperspectral imaging with a 2D sCMOS Camera

- For line-image scanning, in a push-broom hyperspectral configuration
- High throughput, USB-3 system featuring a fast 2D scientific BI CMOS with rolling shutter, running at 94 (HDR) to 188 (Standard Mode) frames per second (2048 pixels per spectrum)

OEM Spectrometer Selection Guide

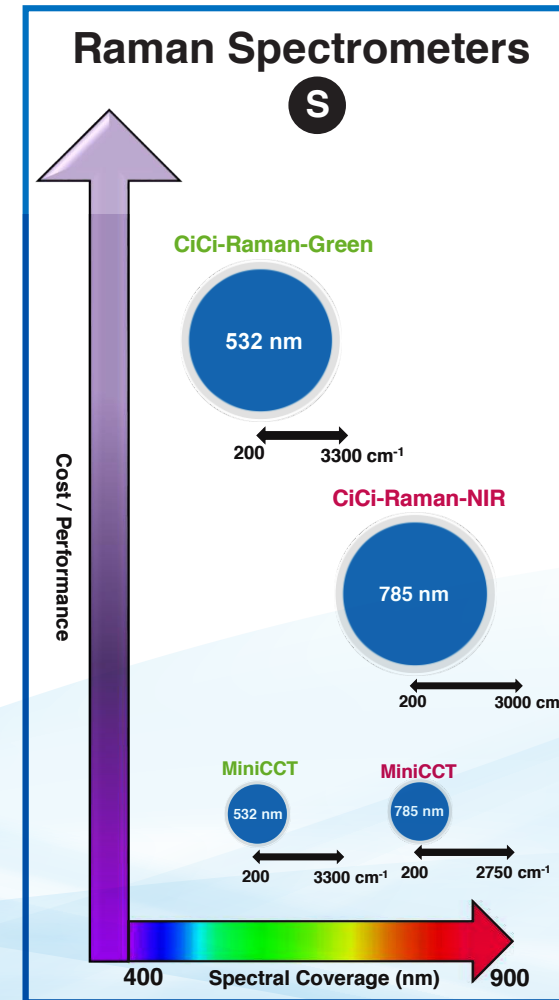
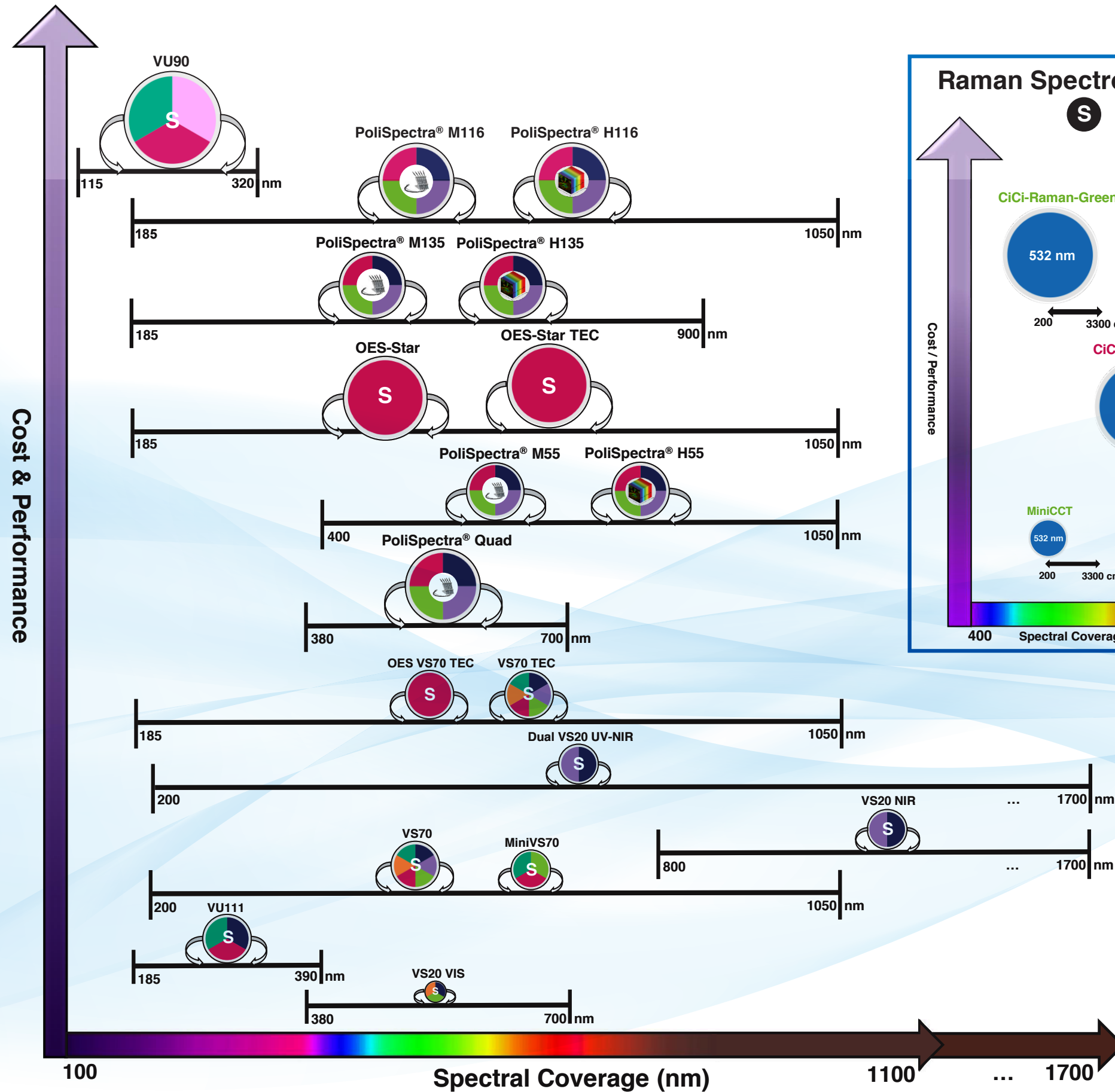

Legend

Spectrometer Input Type

- S** Single-fiber Input
- Multi-fiber Input
- Hyperspectral Imager

Technique & Application

- Emission (OES)
- Absorbance
- Fluorescence
- Reflectance
- Raman
- Metrology
- Photoluminescence
- Colorimetry

Spectrometer Size

- ≤ 10.5x9x7 inches
- ≤ 8x8x8 inches
- ≤ 7.5x4.5x5 inches
- ≤ 7.5x4.5x3 inches
- ≤ 6x6x7.5 inches
- ≤ 5x5x5 inches
- ≤ 5x5x2 inches
- ≤ 2x2x2 inches

OEM Philosophy and Mission

3 Centers of Excellence Dedicated to OEM Spectroscopy and Camera Solutions in US, EU, and Asia

Our mission is to provide a complete development and manufacturing experience, from optical simulations to opto-mechanical design and prototyping of spectroscopic and camera systems extending to, and including, electronics, firmware, software design and first articles.

Our products provide superior performance, reliability and stability, combined with robust cost reduction. Capable of flexible high volume production capacity in quantities of hundreds to thousands per year, we offer full confidentiality providing "Black Boxes" or private labelling, using your logo or graphics.

Unmatched customer service is provided by our exceptionally experienced workforce featuring on-time delivery and flexibility, allowing scheduling modifications.

Adhering to Copy Exactly! (CE!) processes, our fully trained staff, from engineering to manufacturing, form a dedicated OEM engineering force that supports you over the lifetime of the product.

Scientific Segment - OEM Products and Capabilities:

- Custom master optical diffraction gratings
- Diffraction grating replicas (concave, convex and flat)
- Spectrometers, optical assemblies with pre-aligned sensors (CCD, PDA, CMOS, InGaAs) using either customers' or HORIBA's OEM electronics
- OES spectrometers
- Spectroscopy systems or modular engines, such as mini fluorometers and mini Raman systems
- Single and double scanning monochromators
- Imaging spectrographs and spectrometers with CCD or CMOS cameras
- Multispectra spectrometers with multiple fiber inputs / MultiTrack spectroscopy
- Hyperspectral system with HORIBA or customer provided camera (Push-broom configurations)
- Cameras: Spectroscopic deep-cooled scientific cameras (1D and 2D CCD & InGaAs – FI and BI)
- OEM electronics for optosensors ranging from PD and PDA to CCD and CMOS sensors
- Imaging cameras: Uncooled and cooled with FI and BI high-end scientific CMOS
- VUV/FUV spectrometers and CCD vacuum and N2-purged cameras

Scientific Deep Cooled CCD, InGaAs and CMOS Cameras



	USA & Canada OEM.US@horiba.com +1 732 494 8660 Ext. 7733	Japan OEM.JAPAN@horiba.com +81 (75) 313 8121	Europe & Asia OEMSALES.JYFR@horiba.com +33 (0) 1 69 74 72 00
--	--	---	---