

PTI QuantaMaster™ Series

Modular Research Fluorometers for Lifetime and Steady State Measurements

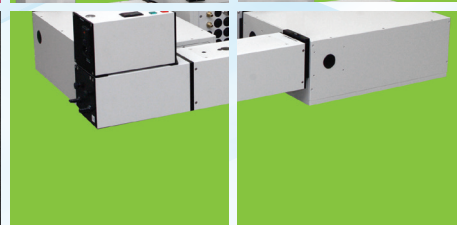
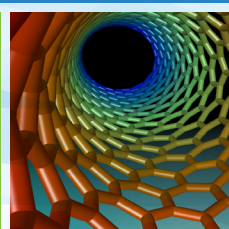
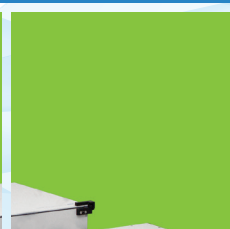
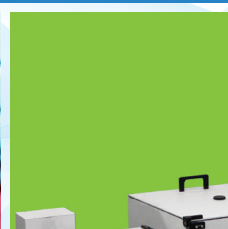
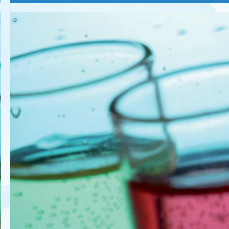

Most sensitive and flexible fluorometers

Unique PTI QuantaMaster™ Benefits

- *Highest guaranteed sensitivity specification*
- *World class software for all steady state and lifetimes needs*
- *Extended wavelength range with triple grating monochromators*
- *Multiple light sources and detectors with dual entrance and dual exit monochromators*
- *Excellent stray light rejection with large single or double additive, coma corrected, monochromators*
- *World class TCSPC lifetime enhancements, up to 100 MHz*
- *NIR steady state and phosphorescence lifetime detection to 5,500 nm*

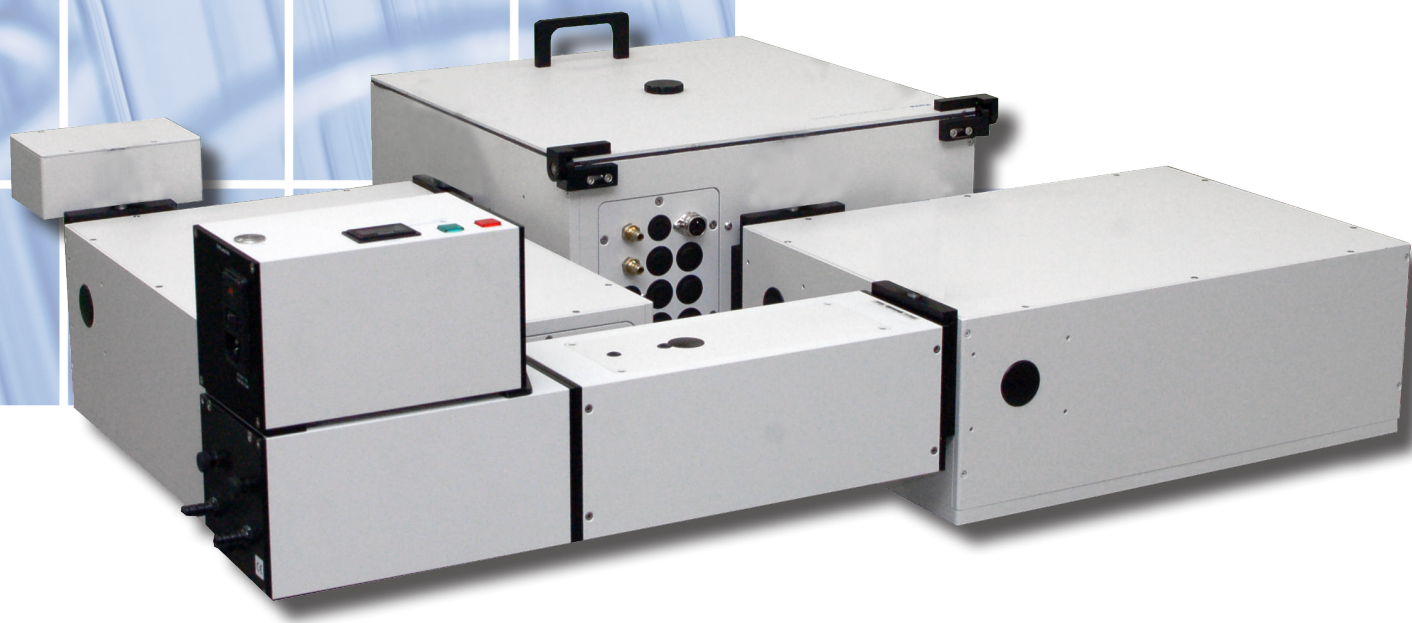



“The new PTI QuantaMaster 8000 series of modular research fluorometers from HORIBA Scientific offer the world’s highest guaranteed sensitivity specifications, plus many unique benefits.”

PTI QuantaMaster 8000 Series

The PTI QuantaMaster™ series of modular research grade spectrofluorometers are multidimensional systems for photoluminescence measurements. The foundation of a fluorescence spectroscopy laboratory is built on steady state intensity measurements such as wavelength scans, time-based experiments, synchronous scans and polarization. The PTI QuantaMaster 8000 series ensures you get the best possible results for all these measurements with high sensitivity, spectral resolution and stray light rejection. This level of sensitivity is achieved using a unique xenon illuminator, providing safety, cost, and energy consumption benefits not found amongst competitor companies. These conditions make the PTI QuantaMaster system ideal for the highest demands of fluorescence research.

The PTI QuantaMaster system is adaptable to every research need, with additions such as TCSPC fluorescence lifetimes, upconversion lasers and phosphorescence detection up to 5,500 nm. Using an optional pulsed light source allows for not only spectral and kinetic fluorescence and phosphorescence measurements, but also the measurement of lifetimes in the picosecond to seconds range. This addition is especially beneficial when using fluorescent probes prone to photobleaching, and when characterizing inorganic material with longer lifetimes. The modular design of the PTI QuantaMaster 8000 series ensures that your system can be easily adapted to your growing research needs.

Ultimate Sensitivity

The industry standard for sensitivity of a fluorometer is the signal-to-noise ratio calculated from a water Raman spectrum. Using this standardized test, our signal-to-noise ratio has been demonstrated to be the highest. The extreme sensitivity of the PTI QuantaMaster fluorometer is achieved with the lowest wattage lamp in the industry. This is a result of the intelligent engineering of the unique PTI PowerArc™ arc lamp illuminator featuring an ellipsoidal reflector with the highest possible light gathering efficiency of 67%, and focusing the light in a tight spot at the monochromator slit. As a result, the standard 75 W Xe delivers light to the sample more efficiently than higher power lamps featured by other instruments. This reduces energy waste and excessive heat generation by an overpowered light source, not to mention cost, while exceeding the sensitivity of all competitors' designs. Another contribution to the high sensitivity of the PTI QuantaMaster comes from the asymmetrical, aberration-corrected monochromator, optimized for the best light throughput and stray light rejection.

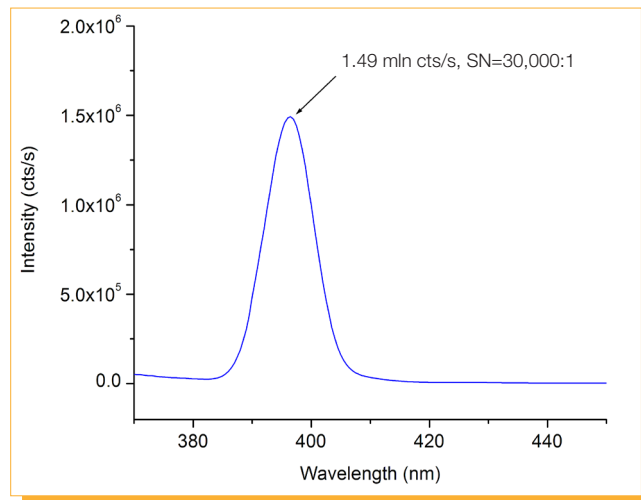

Water Raman spectrum of the PTI QuantaMaster 8000, resulting in a signal-to-noise ratio of >30,000:1! (Experimental conditions: $\lambda_{\text{exc}} = 350 \text{ nm}$, $\Delta\lambda_{\text{exc}} = \Delta\lambda_{\text{em}} = 5 \text{ nm}$, $\text{int} = 1 \text{ s.}$)

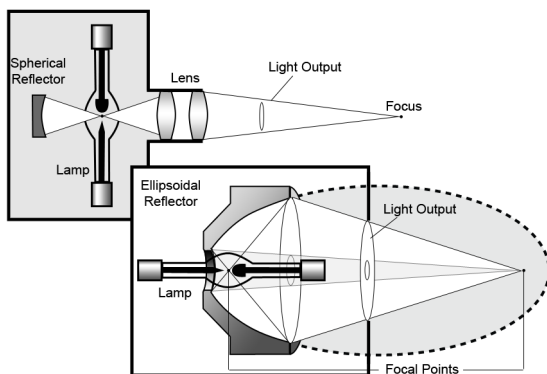

Superior optical design of the PTI QuantaMaster 75 W Xe lamp illuminator is a key factor in PTI QuantaMaster 8000 sensitivity.

Want a higher wattage light source?

No problem. We offer a 450 W lamp that retains the same system sensitivity.

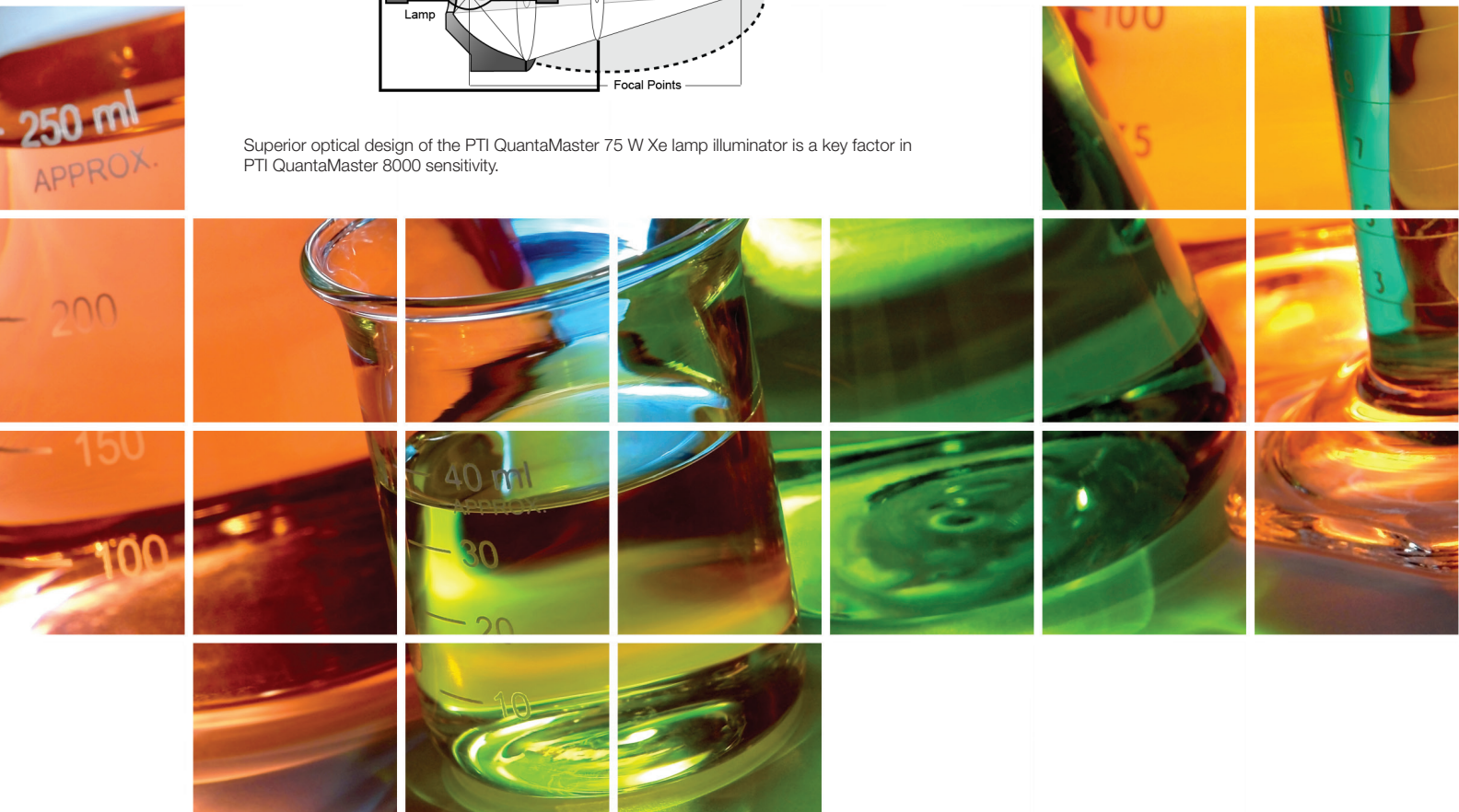

Ultimate Stray Light Rejection

With Single or Optional Double Additive Monochromators

Suppression of stray light is one of the most critical factors when measuring highly scattering, or low quantum yield samples. Every PTI QuantaMaster 8000 series spectrofluorometer is custom made with the highest quality optics to insure the lowest amount of scatter. The standard 300 mm focal length asymmetrical Czerny-Turner monochromators are coma-corrected and individually optimized for purpose as either excitation or emission monochromators, ensuring the lowest amount of stray light contamination for the best detection of the true fluorescence signal. These monochromators boast an impressively high stray light rejection of 1×10^{-5} in a single excitation monochromator configuration. For more sensitivity and higher performance, the PTI QuantaMaster 8000 can also be configured with double additive 300 mm focal length monochromators, improving the stray light rejection to 1×10^{-10} . The PTI QuantaMaster 8000 also offers an optional order sorting filter wheel for rejection of second order signals from large spectral scans. This ultimate stray light performance was motivated by an increasing demand for photoluminescence spectrometers in materials science, where strongly scattering samples, such as powders, wafers and films, are routinely used. Very low stray light performance will also benefit researchers working in biological, biomedical and environmental areas where cell suspensions, protein and biomembrane solutions, or soil samples, generate high levels of scattered light.

Resolution

Resolution is of utmost importance to photoluminescence research. High quality resolution can reveal detailed spectral features which is indispensable for applications in materials science and analytical chemistry. Resolution is the key to detecting very narrow lines, which is necessary to study fine interactions in inorganic materials and crystals. The PTI QuantaMaster 8000 yields high quality resolution due to innovative optical design, and very minimal optical aberrations.

The PTI QuantaMaster 8000 series spectrofluorometers use a precision-driven asymmetrical, 300 mm focal length Czerny-Turner monochromator with a motorized triple grating turret and motorized flipping mirrors. More than 30 different gratings are available. Due to the combination of the computer-controlled motor with micro-stepping resolution and available grating selection, it is possible to achieve a minimum 0.022 nm step size. This means that within the UV and Vis spectral regions, you can resolve spectral features well below 0.1 nm.

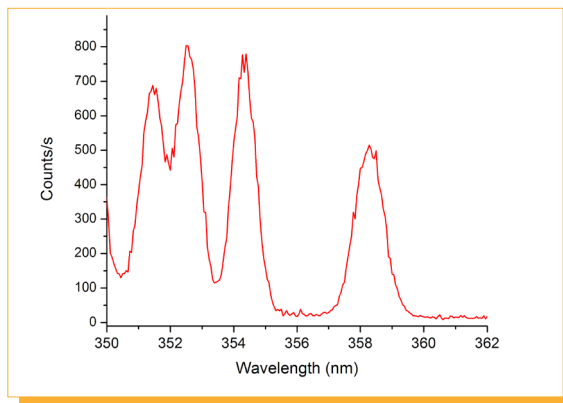

Raman spectrum of CCl₄ using a PTI QuantaMaster 8000 with single excitation & single emission monochromators. Well-resolved peaks and no contamination from the Rayleigh scattering demonstrates the excellent stray light suppression. (Experimental conditions: $\lambda_{\text{ex}} = 349 \text{ nm}$, $\Delta\lambda_{\text{ex}} = 0.7 \text{ nm}$, $\Delta\lambda_{\text{em}} = 0.7 \text{ nm}$, step size = 0.05 nm, integration time = 1 s.)

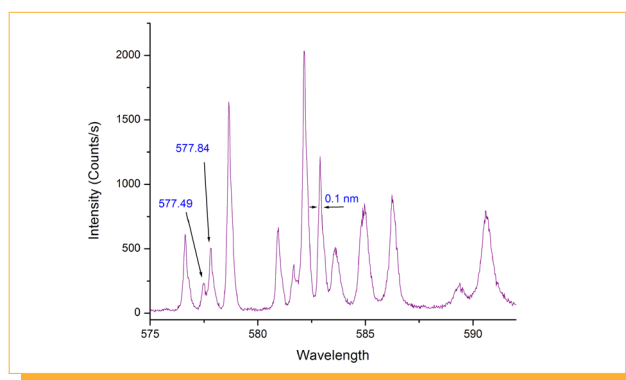
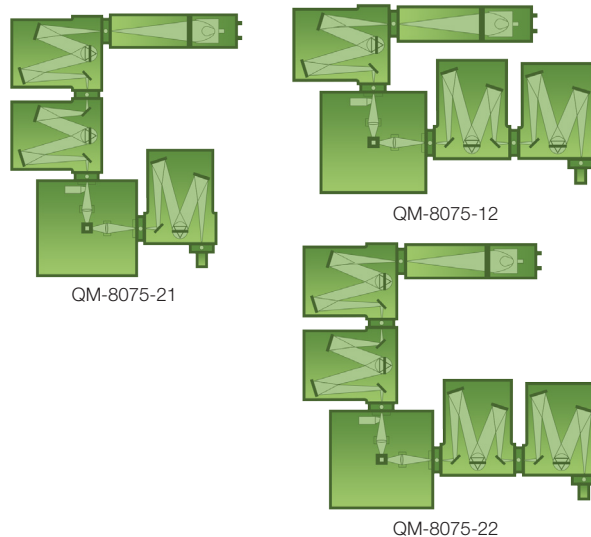

Emission scan of Dysprosium-doped YAG crystal measured at 78K in software controlled LN cryostat illustrating excellent resolution of narrow spectral lines attained at low temperature. (Experimental conditions: $\lambda_{\text{ex}} = 353 \text{ nm}$, $\Delta\lambda_{\text{ex}} = 5 \text{ nm}$, $\Delta\lambda_{\text{em}} = 0.1 \text{ nm}$, step size = 0.022 nm, integration time = 1 s.)

Spectral Range and Signal Detection

For most applications, the typical detector employed is a PhotoMultiplier Tube (PMT). The standard PTI QuantaMaster 8000 configuration features a highly sensitive PMT, with the option of photon counting, analog, TCSPC and SSTD detector modes. The PTI QuantaMaster series offers you the ability to customize the system to meet your applications needs. Digital detection, or photon counting, offers the highest sensitivity as it records single photon events. The analog detection measures the current that is generated on the PMT anode, and provides for additional detection gain control. This greatly enhances the dynamic range of the instrument, especially for higher intensity signals. For NIR and IR applications, we also offer specialized PMTs and solid state detectors, such as InGaAs, PbS and InSb diode detectors that are capable of detecting out to 5500 nm. Most of these detectors can be used with pulsed light sources for time-resolved photoluminescence. Multiple detectors can be used with a single instrument: a single monochromator will accept two, and a double monochromator, up to three detectors. The selection is done by computer-controlled steering mirrors which direct the emitted light to a selected detector. A triple, motorized grating turret ensures good light efficiency for any detector range.



Excitation and Emission Correction

All light sources emit light that is not of equal intensity across the output spectrum, and this can lead to errors in the measurement of an excitation spectrum. The raw data must then be corrected for this discrepancy. The PTI QuantaMaster 8000 utilizes a reference diode detector that has been calibrated and installed at the factory. Excitation correction is performed in real time. During an experiment, part of the excitation beam is diverted prior to reaching the sample. This fraction of photons is measured, and then the reference detector provides a correction that is independent of the excitation source characteristics, or any temporal fluctuation of the lamp intensity, thus ensuring excellent stability of the signal.

A similar phenomenon exists for emission spectra. Since the detection efficiency of the optics, gratings, mirrors and detector is not equivalent at all wavelengths, some type of correction must be performed to account for these variations. Typically, the emission channel is calibrated at the factory with a known light source, such as a NIST-traceable standard. This information is used to construct a correction file, which is then stored locally on your computer. Multiplication of the raw data by this correction file yields the true corrected emission spectrum. This correction can be performed in real-time, or can be recalled in later analysis of the raw data and applied in the easy-to-use FelixGX software.

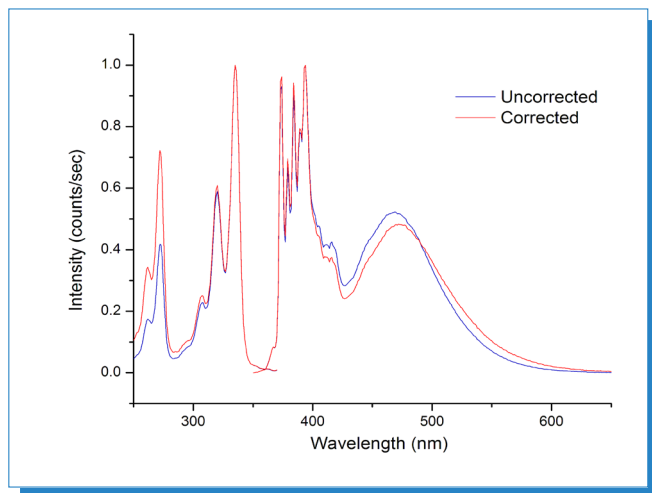

Raw and corrected Pyrene excitation and emission spectra with excimer peak present around 475 nm. Corrected data shown in red.

Specifications

The following specifications are for the standard PTI QuantaMaster 8075-11 and 8450-11 systems. Options and upgrades may be available upon request.

Signal-to-Noise Ratio	>30,000:1 RMS (>15,000:1 FSD)
Data Acquisition Rate	1,000,000 points/sec. to 1 point/1000 sec.
Inputs	4 photon counting (TTL); 4 analog (+/- 10 volts); 1 analog reference channel (+/- 10 volts); 2 TTL
Outputs	2 analog (+/- 10 volts); 2 TTL
Emission Range	185 nm to 900 nm (optional to 5,500 nm)
Light Source	High efficiency "ECO" friendly continuous 75 W Xenon arc lamp (Optional 450 W Xenon)
Monochromator	300 mm, triple grating, coma-aberration corrected, asymmetrical, excitation or emission optimized, Czerny-Turner design
Slits	Computer controlled, continuously adjustable
Excitation Grating	1200 line/mm 300 nm blaze, (Up to two optional gratings can be ordered)
Emission Grating	1200 line/mm 400 nm blaze, (Up to two optional gratings can be ordered)
Wavelength Accuracy	+/- 0.3 nm
Minimum Step Size	0.022 nm
Standard Detection	Multimode: Photon Counting, 3 analog (fast, medium, slow response), direct and Single-Shot Transient Digitizer (SSTD) mode, and Time-Correlated Single Photon Counting (TCSPC)
System Control	Computer interface with FelixGX spectroscopy software
Lifetime Range	5 ps to seconds with appropriate time-resolved accessories
Dimensions (W x D x H)	36 in x 28 in x 12 in (QM-8075-11)

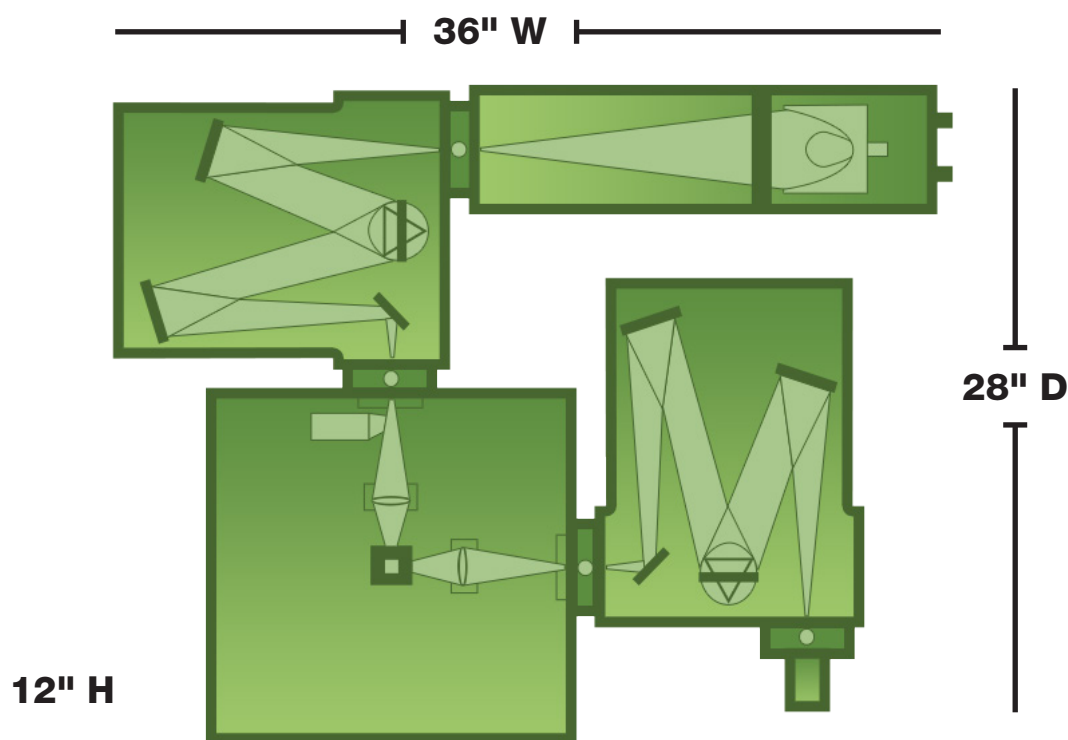

Model QM-8075-11 shown here.

HORIBA Scientific has a policy of continuous product development, and reserves the right to amend part numbers, descriptions and specifications without prior notice.

TCSPC Lifetime Measurements

The PTI QuantaMaster 8000 series can be easily enhanced with TCSPC fluorescence lifetime capabilities. Utilizing world class TCSPC sources, electronics and detectors developed by our IBH group, the PTI QuantaMaster provides the ultimate in speed, versatility and performance. The standard QuantaMaster PMT can be used for these additional TCSPC measurements, or you can add a dedicated TCSPC detector with enhanced performance or extended NIR detection. All steady state and time-resolved control, acquisition and analyses are handled by FelixGX software.

HORIBA TCSPC Benefits

- 40 years of experience in TCSPC innovation
- Industry-leading true 100 MHz system operation allows for millisecond acquisition times
- TCSPC lifetime measurements from 5 ps to seconds
- Full control over TCSPC and steady state acquisitions with single FelixGX software package
- Measure TCSPC lifetimes, time-resolved anisotropy and TRES (Time-Resolved Emission Spectra)
- Select from our catalog of over 60 state-of-the-art compact pulsed LEDs and Laser Diodes for virtually any application
- For unsurpassed versatility, choose a picosecond supercontinuum laser with HORIBA's proprietary Frequency Doubler—a powerful tool for time-resolved protein studies
- PowerFit-10 decay analysis package with multiple fitting models including a unique Maximum Entropy Method (MEM) lifetime distribution program

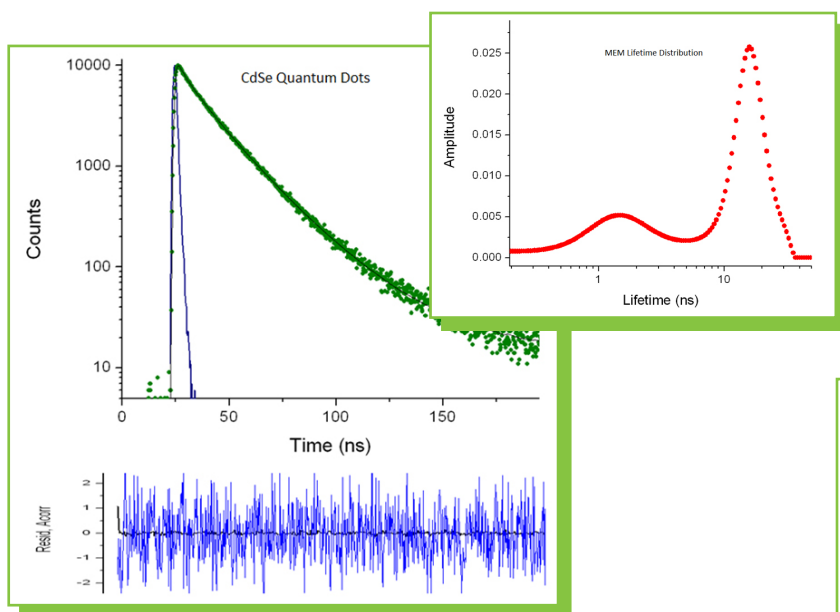

Fluorescence decay of CdSe QDots measured with TCSPC option of QuantaMaster. The MEM lifetime distribution (inset) reveals size heterogeneity of QDots.

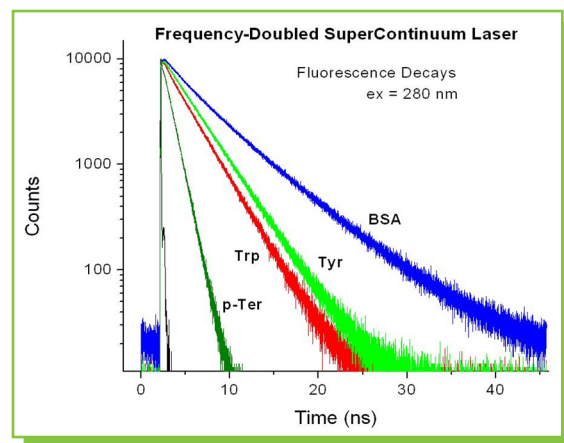

PTI QuantaMaster 8000 with DeltaTime TCSPC option and frequency doubled supercontinuum laser is a perfect choice for intrinsic protein TR fluorescence.

Two Systems Can Be Better Than One!

We also offer very affordable stand-alone TCSPC systems. You can increase your lab's throughput by having a dedicated steady state fluorometer and a dedicated TCSPC system operating at the same time, for almost the same price as adding TCSPC to the PTI QuantaMaster.

Phosphorescence with SSTD Detection

Phosphorescence with a Pulsed Light Source

Adding a pulsed light source to a standard QuantaMaster 8000 provides enhanced phosphorescence with no other detection or electronics required. A pulsed light source and the ability to integrate the signal at user-selectable time delays are indispensable tools in discriminating spectra based on the lifetime of the respective excited state. Fluorescence emission happens on the picosecond to nanosecond time scale, while phosphorescence occurs on the microsecond to second time scale. By varying the temporal position and the width of the signal detection gate, one can selectively detect fluorescence and phosphorescence spectra as attested by Phenanthrene spectra on the accompanying figure. Here, the emission of Phenanthrene in a frozen glass was measured with gradually increased time delay of the detection gate to diminish contribution of fluorescence. However, the true potential of this technique can be seen in the case of Room Temperature Phosphorescence (RTP) of RNase T1 Tryptophan, where the signal was extracted by gating out the overwhelming Trp fluorescence—a task impossible with a continuous excitation source. Conveniently, the same instrument can be used to measure phosphorescence decay of this extremely weak emission by using the Single-Shot Transient Digitizer (SSTD) function of the PTI QuantaMaster interface.

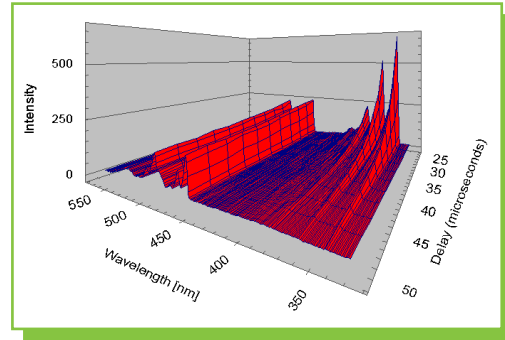

Phenanthrene at 77 K utilizing a cold finger nitrogen dewar accessory. Fluorescence and phosphorescence spectra measured while increasing the delay time (at 2 μ s increments) for signal integration.

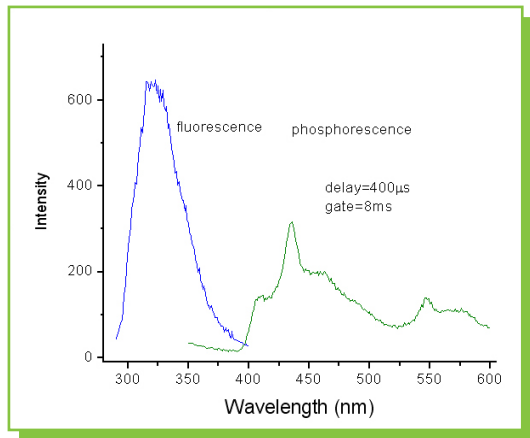

Discrimination between strong fluorescence and weak Room Temperature Phosphorescence (RTP) from RNase T1 Tryptophan by varying the temporal position and widths of the signal detection gate on a PTI QuantaMaster 8000 equipped with a pulsed Xe lamp and gated detector for signal integration.

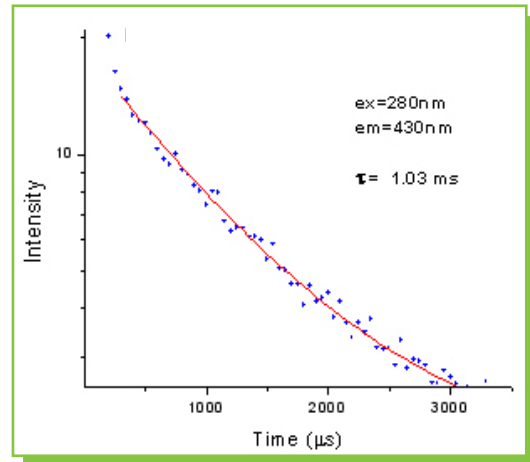

Phosphorescence decay of a weakly emitting RNase T1 Tryptophan signal using the same instrument.

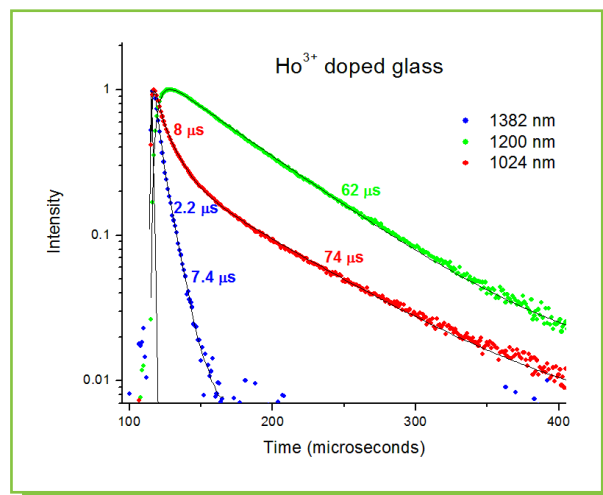

PL decays of Ho^{3+} doped glass measured with the PTI QuantaMaster 8000 system operating in the lifetime mode. Note that the decays are very different for different transitions. The decay at 1200 nm also shows a rise time of 2.4 μ s.

Flexibility

Enhanced Measurements

Many Configurations to Fit your Specific Needs, and Modularity to Grow

The PTI QuantaMaster 8000 series features an open architecture design that provides the ultimate in versatility to adapt to any future fluorescence application needs. You can optimize the initial configuration by choosing the light source, gratings, and PMTs, as well as a wide array of available accessories. The number of available configurations is virtually limitless!

The PTI QuantaMaster 8000's universal QuadraCentric™ sample compartment has a spacious design that provides accessibility, and can accommodate a wide selection of sample accessories. Choose from sample temperature controllers to various holders for solids, liquids and powders, dewars, integrating spheres and many other options. See the Accessories page for more details.

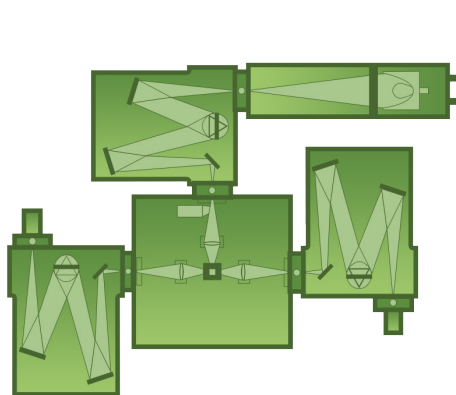

PTI QuantaMaster 8075-11 with a second emission channel.

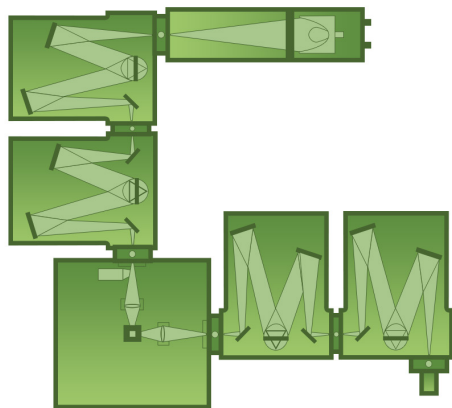

PTI QuantaMaster 8075-22 fluorometer with double additive excitation and double additive emission monochromators, for the ultimate in stray light rejection.

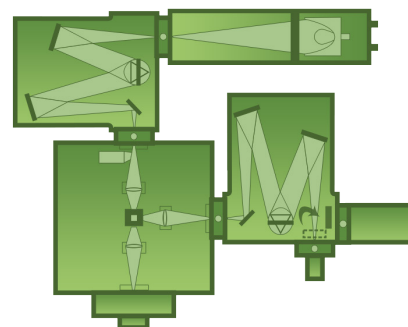

PTI QuantaMaster 8075-11 with TCSPC lifetimes with DeltaDiodes or NanoLEDs and detection.

The open architecture design also allows for application and methodology changes. As your application needs grow, so can your PTI QuantaMaster. For example, if you develop a need to measure dynamic anisotropy, you can add a second emission channel and a set of polarizers. If you want to complement your steady state data with lifetime measurements, you can add a laser or LED-based excitation to your initial configuration. If you are interested in intracellular Ca^{2+} after completing initial Fura-2 studies, you may decide you would like to start imaging the events. The system can be easily coupled with any fluorescence microscope. Whether you choose to add NIR detection or a second excitation source, the possible configurations are endless.

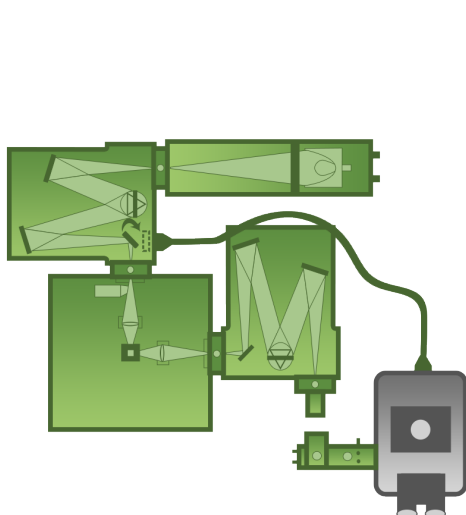

PTI QuantaMaster 8075-11 upgraded to fluorescence microscopy with an additional PMT detector equipped with an eyepiece aperture.

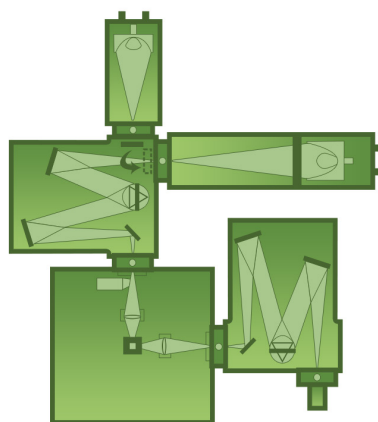

PTI QuantaMaster 8075-11 with a pulsed light source and a gated detector for phosphorescence or Lanthanide emission.

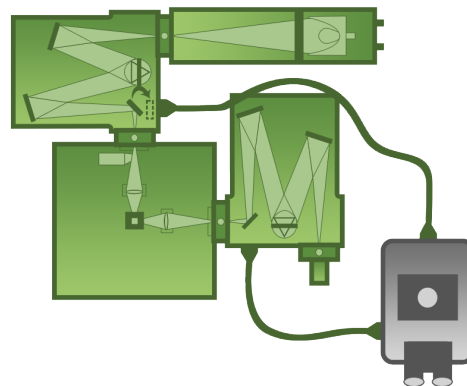

PTI QuantaMaster 8075-11 coupled to a microscope with detection into the existing emission monochromator.

Near-Infrared Spectrofluorometry

Near-infrared (NIR) spectrofluorometry has emerged as a valuable analytical technique, especially in the fields of material research, nanotechnology, chemistry, and photomedicine. Powerful and diverse NIR capabilities are available from HORIBA as either a stand-alone research grade fluorometer, or as an upgrade to our UV-Vis steady state spectrofluorometers. There are different configurations to adapt to any research needs.

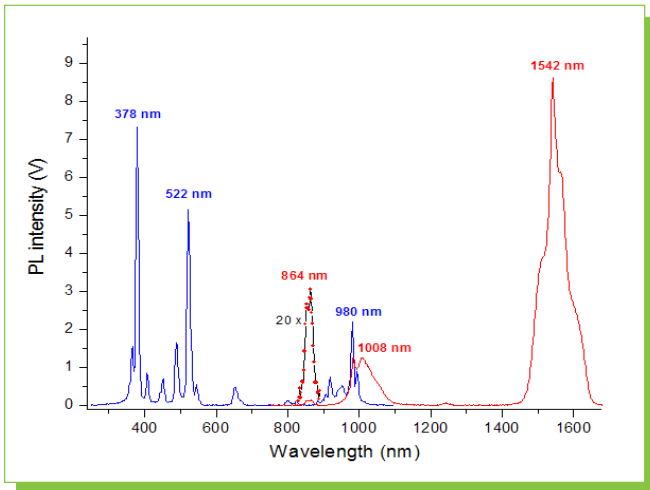

PL excitation and emission spectra of Er³⁺ doped glass measured with the PTI QuantaMaster 8000 equipped with the NIR TE-cooled InGaAs detector.

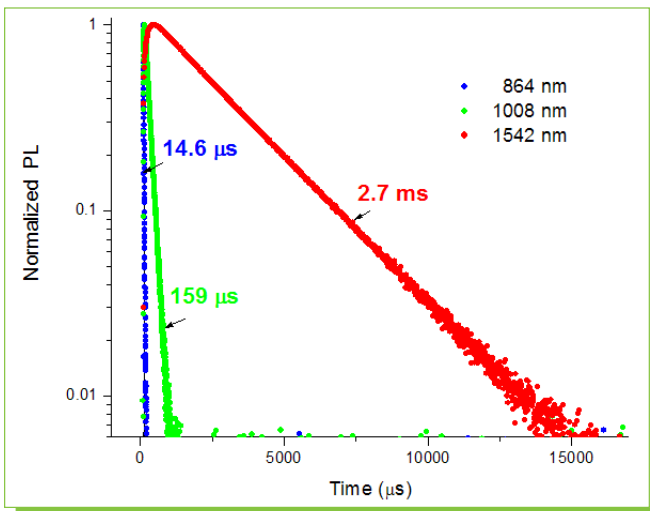

Er decays: PL decays of Er³⁺ doped glass at different emission peaks measured with the PTI QuantaMaster 8000 system equipped with the NIR TE-cooled InGaAs detector and pulsed nitrogen/dye laser excitation.

NIR-PMT Based Detectors

These detectors offer the ultimate in sensitivity and can be used for steady state and TCSPC measurements.

Available with four NIR PMTs for maximum spectral range coverage:

- 300–1,400 nm, LN-cooled
- 950–1,400 nm, TE-cooled
- 300–1,700 nm, LN-cooled
- 950–1,700 nm, TE-cooled

Solid State Photodiode-Based NIR Detectors

There are a variety of photo diodes available, with TE- or LN-cooling and a lock-in amplifier and chopper for enhanced sensitivity.

- InGaAs: 500–1,700 nm (up to 2400 nm detector available upon request)
- PbS: 1,000–3,200 nm
- InSb: 1,500–5,500 nm

NIR Lifetime Measurements to 5,500 nm!

All of the detectors listed above can be used in a Single-Shot Transient Digitizer (SSTD) mode for luminescence lifetime measurement capability in NIR to measure lifetimes from 1 μs to hundreds of ms. SSTD is extremely fast and offers outstanding signal-to-noise, using:

- Variable high rep rate pulsed xenon lamp option for phosphorescence lifetime (NIR-TR-10)
- Pulsed nitrogen and dye laser (NIR-TR-20)
- 3rd party pulsed Q-switched lasers
- TCSPC lifetime add-on with supercontinuum laser, laser diodes and LEDs (for NIR-PMT based systems)

Flexibility

Enhanced Measurements

Unique NIR Solutions

A PTI QuantaMaster 8000 can be equipped with multiple illuminators and detectors to cover the widest spectral range for both steady state spectra, and fluorescence and phosphorescence lifetimes. Consider the following configuration:

- Double emission monochromator with R928 PMT, InGaAs and InSb detectors cover 250 to 5,500 nm
- Continuous Xenon lamp for steady state spectra
- 20 Hz Q-switched/OPO Opolette laser for tunable excitation from 210 to 2,200 nm
- Frequency doubled nitrogen pumped dye laser for tunable excitation from 250 to 990 nm
- Steady state spectra from 250 to 5,500 nm
- Single-Shot Transient Digitizer (SSTD) for phosphorescence decays over entire range from 250 to 5.500 nm

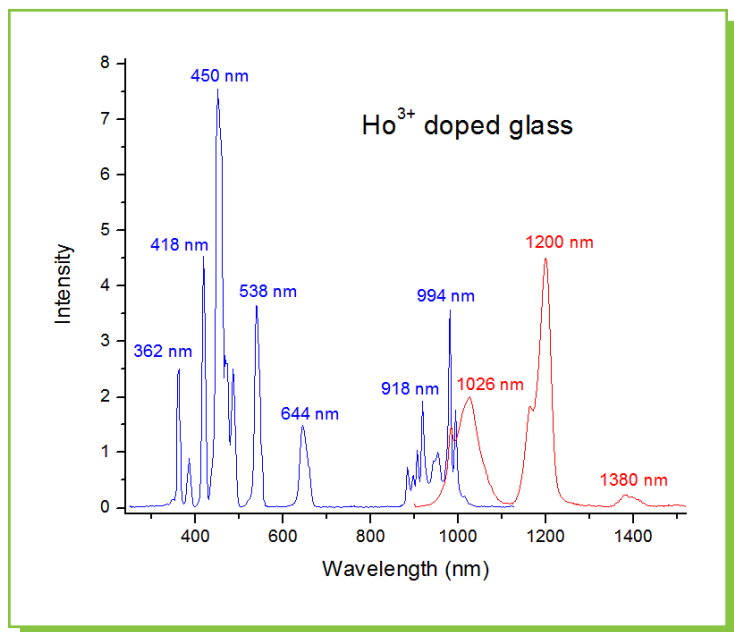

Ho ion emission and excitation spectra in NIR measured with 75 W CW Xe lamp and InGaAs detector.

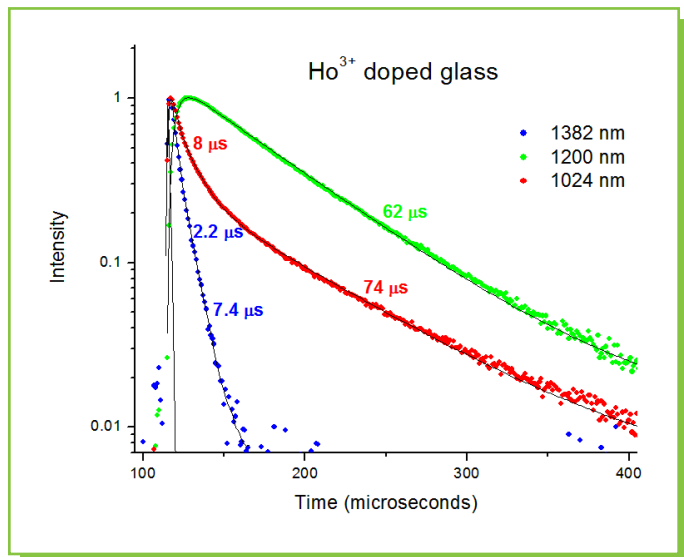

Ho ion PL lifetimes in NIR measured with pulsed N₂/dye laser and InGaAs detector.

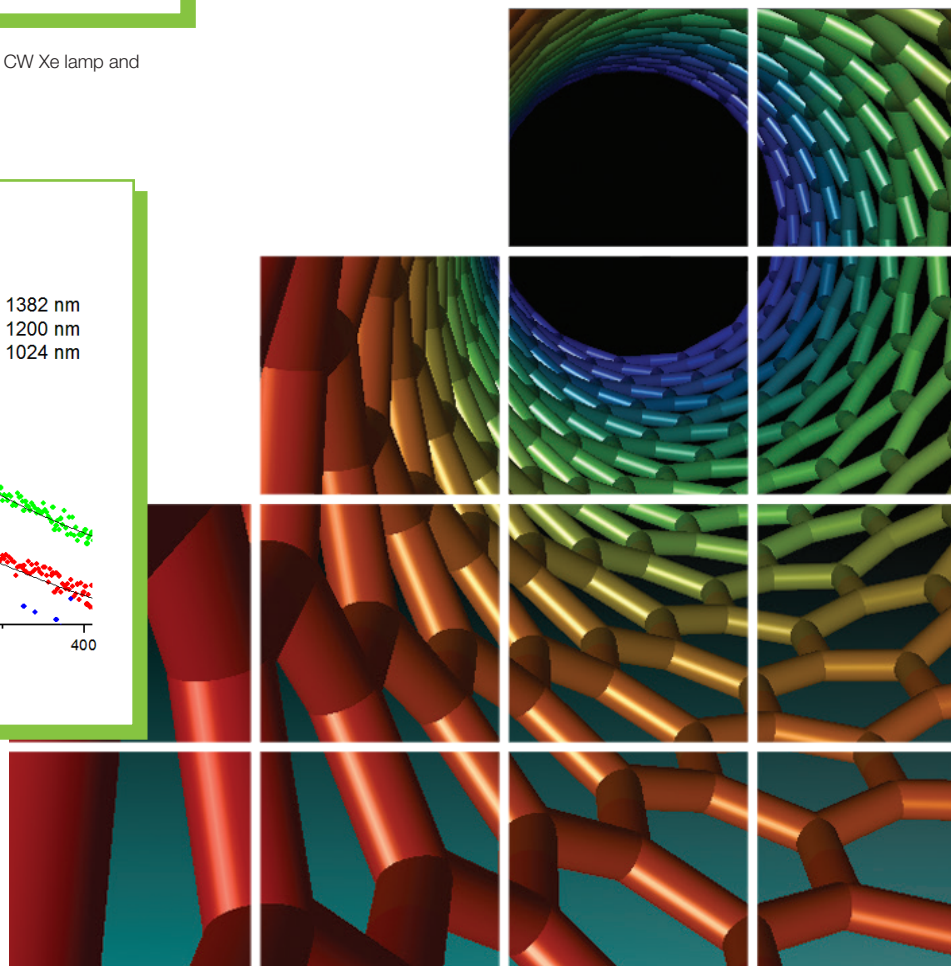

Unique NIR Solutions

Flexibility

Enhanced Measurements

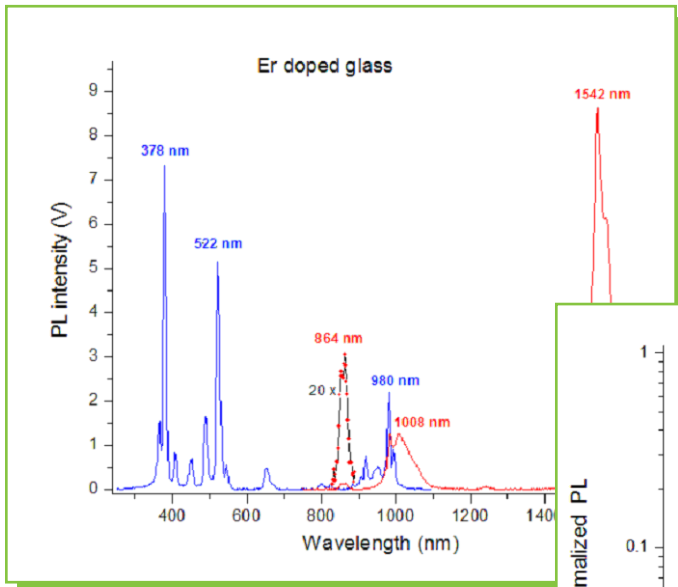

Spectra and PL lifetimes in NIR of Er-doped glass measured with continuous Xe lamp and pulsed N_2 /dye laser excitation with the same InGaAs detector.

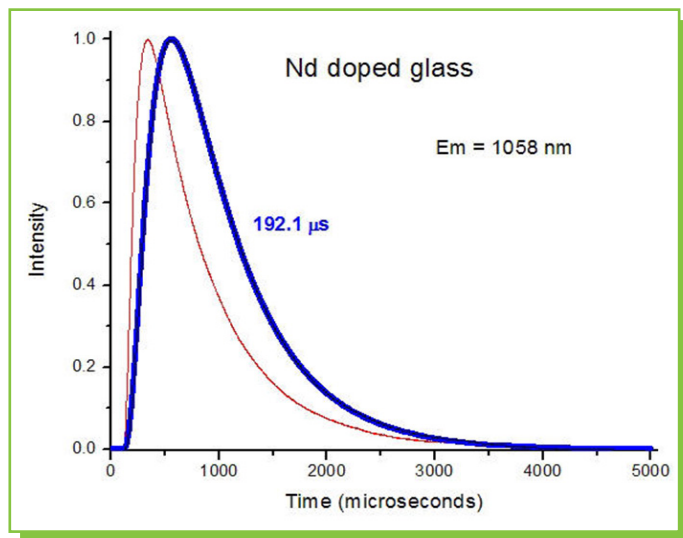
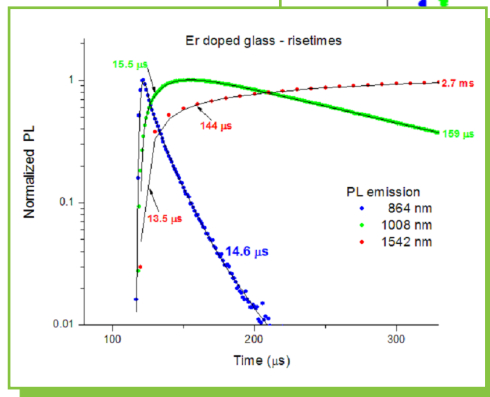
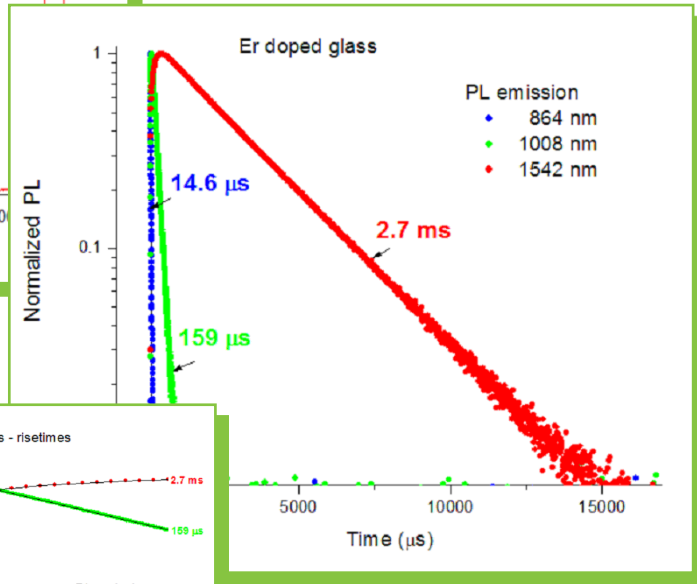

Nd decay with PbS detector - deconvolution required.

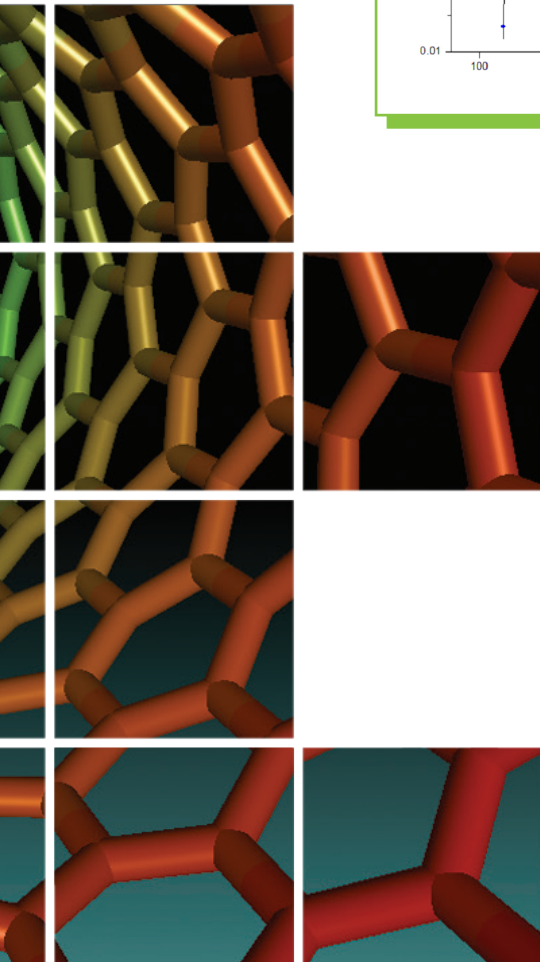

FelixGX Software

PTI QuantaMaster 8000 fluorometers come with our integrated FelixGX software to control both the instrument and accessories. Designed to be complete and easy to use, FelixGX includes analytical functions for trace manipulation, and spectral and kinetic analysis. Connected with a USB interface, FelixGX provides a full set of data acquisition protocols, and controls the hardware for all system configurations and operating modes.

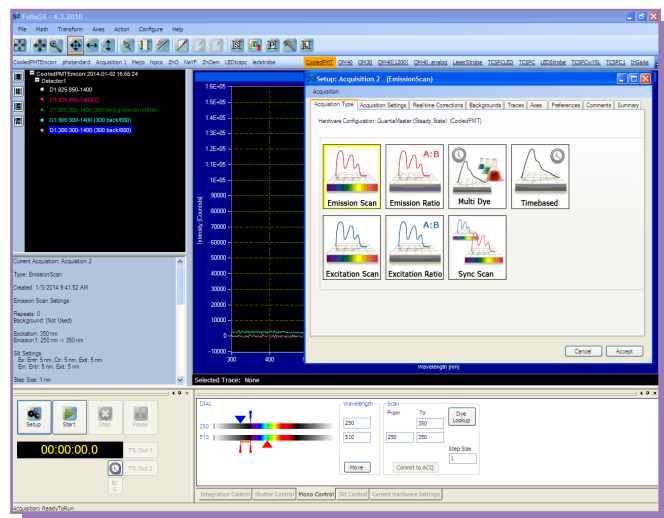

FelixGX Controls

Hardware Controls

- Single or double monochromators
- Triple grating turret
- Flipping mirrors switching between different light sources and detectors
- Motorized slits
- Motorized polarizers
- Motorized multiple sample holders
- Excitation correction detector (Xcorr)
- Temperature control Peltier devices
- Cryostat
- Gain control of PMT detector
- Switching from digital to analog mode
- External devices such as stopped flow and titrator
- Pulsed light sources
- Scanning of wavelength-tunable OPO lasers
- TCSPC electronics
- Electroluminescence and photovoltaic accessories
- Supercontinuum lasers

Macro Capabilities

FelixGX comes equipped with Macro capabilities to allow for automated measurements. Choose from a list of actions to make a chain of commands, or set up a loop function to eliminate the need to constantly change the acquisition settings. Set up the automation job and simply walk away, letting FelixGX execute your instructions.

Acquisition Modes

FelixGX provides several acquisition modes for spectral and kinetic measurements:

- Excitation and emission spectral scans with user control of integration time, monochromator step, speed and wavelengths
- TCSPC
- Time-based scan with user defined macro-time duration and integration time
- Spectral and time-based polarization scans with full control of motorized polarizers and automated measurement of G-factor, and sample background for all polarizer orientations
- Simultaneous multi-dye measurements with pre-defined library of common fluorescence dyes or customer-defined dyes
- Synchronous excitation/emission scan
- Excitation and emission ratio fluorescence
- Phosphorescence decay and time-resolved excitation and emission spectra using Single-Shot Transient Digitizer (SSTD)

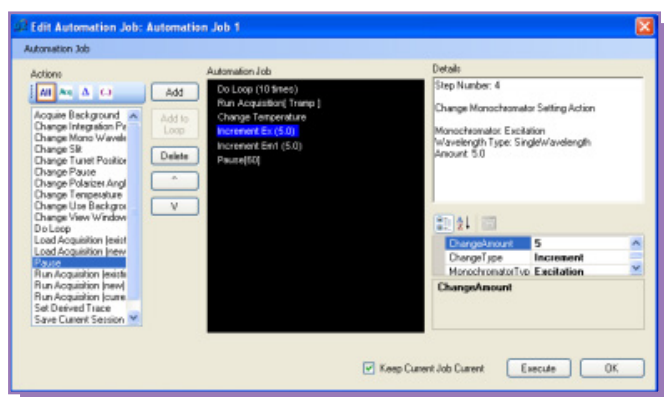

FelixGX Analytical Capabilities

Trace Manipulation

FelixGX also provides an extensive set of math functions that can be used for processing and manipulation of acquired data traces:

- Antilog
- Average
- Distribution average
- XY Combine
- Differentiate
- Integrate
- Linear Fit
- Linear Scale
- Logarithm
- Normalize
- Reciprocal
- Smooth
- Truncate
- Baseline
- Merge Traces
- Peak Finder

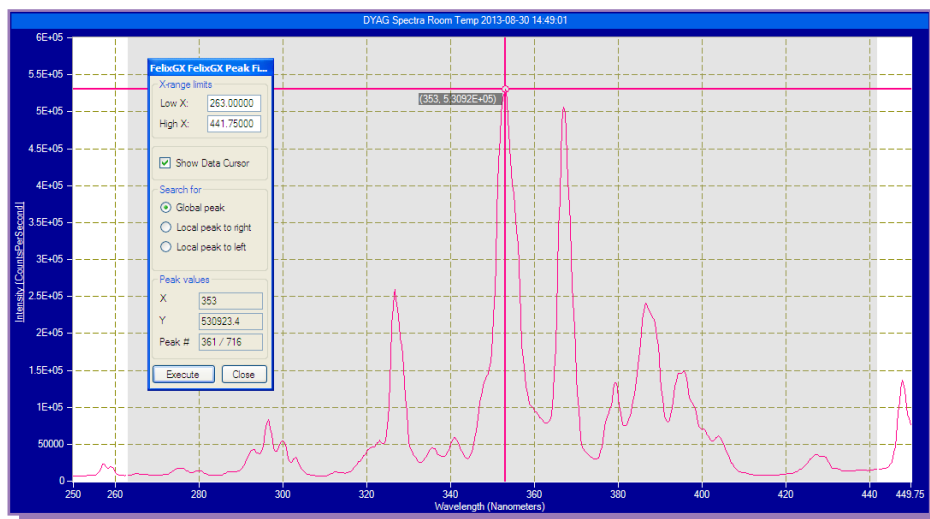

Demonstration of Peak Finder function with an emission spectrum.

Kinetic Data

Fluorescence and phosphorescence decays can be analyzed with the TCSPC lifetime analysis package which includes:

- One to four exponentials
- Multi one to four exponentials
- Global one to four exponentials
- Anisotropy decays
- Exponential Series Method (ESM) lifetime distribution
- Maximum Entropy Method (MEM) lifetime distribution
- Micelle kinetics
- Stretched exponential
- DAS (Decay Analysis Software)/TRES

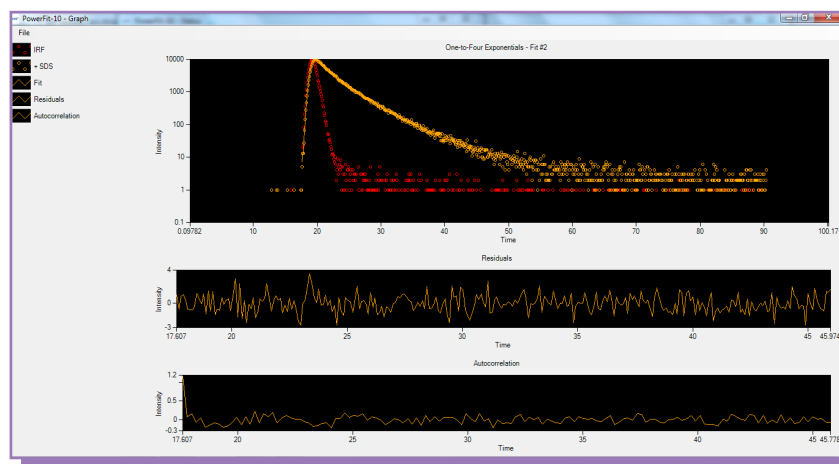

TCSPC output graph with residuals and autocorrelation.

Advanced Calculators

Single-Walled Carbon Nanotube Calculator

Carbon nanotubes can be characterized using the specially-designed NanoCal within FelixGX. NanoCal analyzes 3-D ExEm spectral maps and returns structural parameters such as the nanotube radius and the chiral angle. Combining this easy-to-use software with PTI QuantaMaster 8000 NIR options allows for full characterization of SWCNTs.

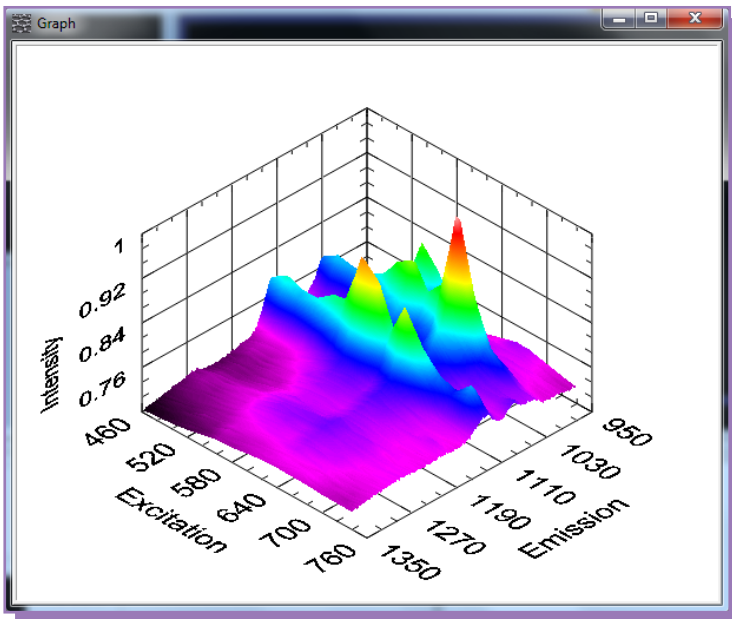
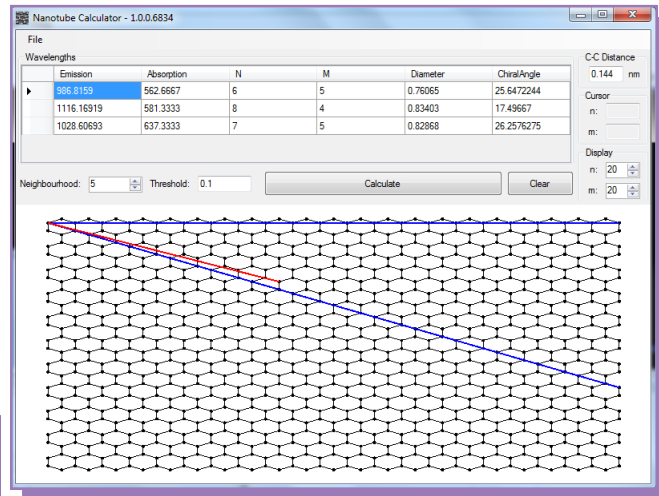

Color Coordinate Calculator

In many applications, such as phosphors for screen displays, multi-color LEDs, fluorescent additives to consumer products, etc., there is a need to quantify a visual perception of color. FelixGX provides a Color Coordinate Calculator based on two widely accepted standards introduced by the International Commission on Illumination, CIE 1931 and CIE 1976. The CIE 1931 uses x, y chromaticity coordinates where each x, y pair corresponds to a unique color within the colored shape. The CIE 1976 uses a system with more uniform perceptual chromaticity to define the color space using u, v coordinates. Upon highlighting a spectral trace and clicking on CIE 1931 and CIE 1976 Color Coordinates, FelixGX will display both CIE pairs.

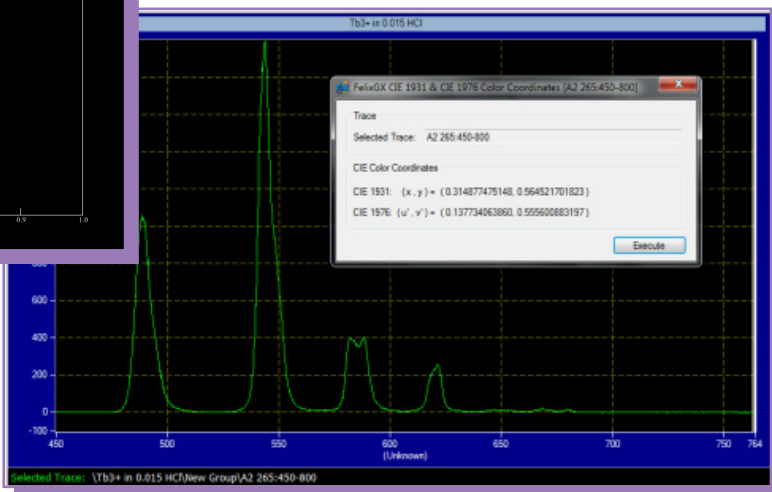
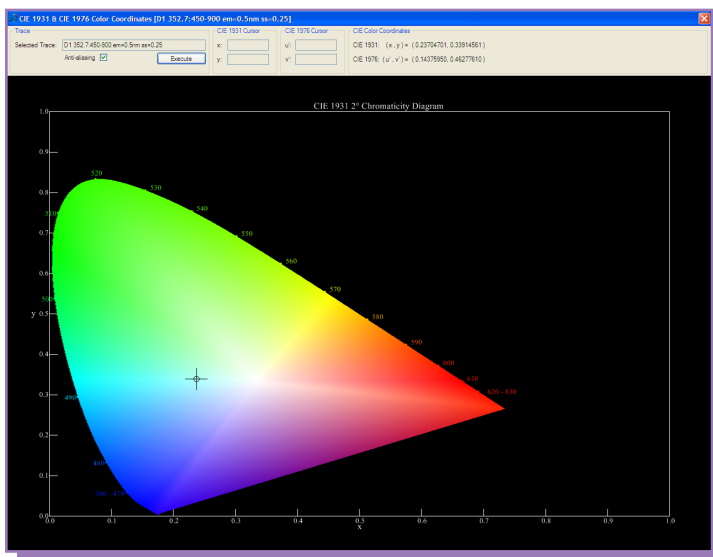

Advanced Calculators

FelixGX also offers a special set of software functions, such as quantum yield, absorption, FRET and color coordinates calculators, as well as the software that calculates structural parameters for single-walled carbon nanotubes. These are very convenient additions to some accessories, such as the integrating sphere or absorption accessory, and are also indispensable for some fluorescence applications, such as intermolecular interactions (FRET) and materials characterization.

Absorption Calculator

Absorption measurements are complementary to fluorescence. They are necessary for fluorescence quantum yield determination, and are an easy and convenient way to check the fluorophore concentration. You can compare the absorption and excitation spectra to draw conclusions about the purity of the sample. Using the built-in absorption calculator with an absorption accessory will greatly enhance the capabilities of your PTI QuantaMaster 8000 fluorometer.

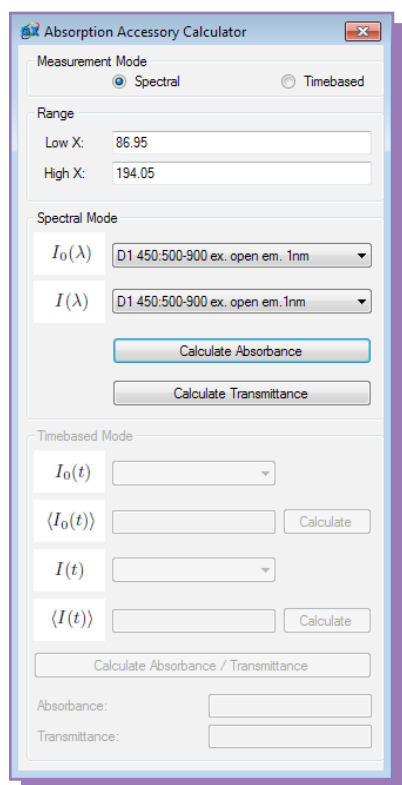

Quantum Yield

Quantum yield is one of the most important parameters that characterize photoluminescence of materials. FelixGX incorporates a quantum yield calculator which, when coupled with an integrating sphere, allows you to calculate the quantum yield with ease.

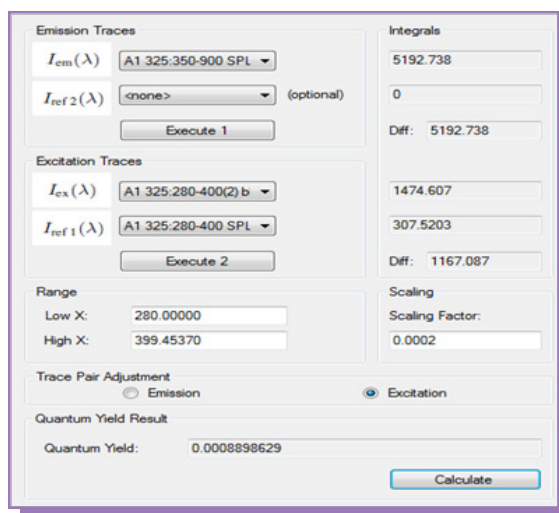

FRET

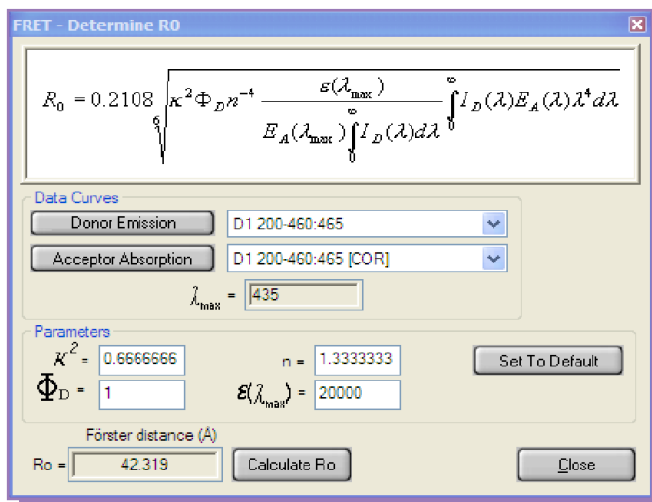

The FRET (Förster Resonance Energy Transfer) technique provides information about molecular distances, interactions in macromolecular systems, binding, diffusion, sensing, etc. FRET happens when an excited donor molecule transfers its energy to an acceptor in the ground state. FRET is essentially a molecular ruler, where distances are scaled with the Förster critical radius R_0 , which is a unique parameter for a given donor-acceptor (D-A) pair, defined by spectroscopic parameters of the pair and their environment. Once the R_0 is known and the FRET efficiency is determined experimentally, the D-A distance and the FRET rate constant can be calculated. From spectra or TCSPC data, FelixGX provides an easy and convenient way of calculating all relevant FRET parameters, including R_0 .

Accessories

Four Position Peltier K-157-C Temperature Control

Fully automated Peltier-based temperature control (-25°C to 105°C) for up to 4 samples measured at pre-set temperatures, or with temperature ramping and simultaneous measurement at all 4 sample positions. Magnetic stirring included.

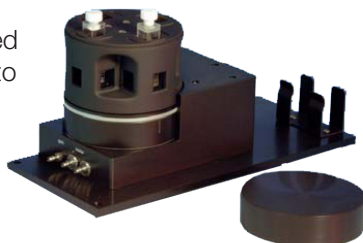

K-Uni-HDLR Universal Holder for Solids, Powders and Cuvettes

Universal sample holder base, capable of both linear and rotational travel, was designed for the measurements of solid compounds, microscope slides, or films. The solid sample holder head, also suitable for slides and films, mounts onto a base and can be removed easily to substitute a powder sample holder head or a cuvette holder which enables front face measurements.

Cold Finger Dewar K-158

The cold finger dewar accessory is designed to be used with liquid nitrogen as coolant (77 K). Includes: quartz cold finger dewar that accepts 5 mm tubes, dewar holder for the sample turret or single cuvette holder, foam lid for the dewar and extension collar with altered sample chamber lid, and a sample compartment. The dewar features a suprasil quartz cold finger that passes light down to about 200 nm. Samples are placed in NMR and EPR tubes, and the liquid nitrogen placed in the dewar will typically last several hours.



Absorption Accessory ABS-ACC

The ABS-ACC absorption accessory fits directly into a cuvette sample holder and enables the user to measure the absorption spectrum, or check the optical density of the sample without reconfiguring the PTI QuantaMaster 8000 fluorometer.

Stopped Flow Accessory K-161-B

The stopped flow accessory is used to rapidly mix small volumes of two (or more) different chemicals in a cuvette, quickly stop the flow of chemicals to the cuvette, and monitor the resulting chemical reaction via optical means. In some instances, the chemical reaction will result in luminescence, and this optical signal can be monitored using a fluorometer. In other instances, the chemical reaction only produces a change in the optical absorption properties and must be monitored using an absorption technique. The primary experimental interest is in the speed of the chemical reaction following the mixing in the cuvette, in addition to the spectral properties of the resulting absorption and/or luminescence.

Cryostat K-CRYO-3/K- CRYO-2

The cryostat can be used between the temperatures of 77 K up to 500 K. FelixGX can control the cryostat remotely to allow computer monitoring of steady state and lifetime measurements.

Muscle Strip Accessory K-162-B

This accessory is ideal for measuring muscle fiber contractility simultaneously with intracellular calcium. The muscle strip is inserted into a standard 1 cm cuvette, combining the lower muscle hook with unique perfusion tubes, a tension transducer with upper muscle hook, and an interface electronic control unit. The accessory can be used with any cuvette-based fluorescence system having a standard single cuvette holder complete with tension transducer and transducer mounting bracket with micrometer position adjustment.



Single Cuvette Peltier K-155-C Temperature Control

The Peltier-based temperature control with magnetic stirring provides unmatched temperature stability and full software control from -15°C to 110°C (-40°C to 150°C optional), including temperature ramping experiments.



Remote Probe Sensing Accessory K-163

The remote probe sensing accessory allows in vitro or in vivo measurement by means of a quartz bifurcated fiber bundle or Liquid Light Guide. One fiber leg is attached to the second exit port of the excitation monochromator to provide excitation light to the sample. The second leg is attached to an open entrance port of the emission monochromator to detect the fluorescence signal emitted from the sample.

Polarizers

HORIBA offers a wide variety of polarizers, ranging from manual sheet polarizers to automated large aperture Glan Thompson polarizers. All configurations allow for automated software control, automatic G-factor determination, and real-time acquisition of HH, VH, VV, and HV analysis. Measure steady state anisotropy in a single emission configuration or dynamic anisotropy utilizing our dual emission configuration.

Total Internal Reflection Fluorescence (TIRF) Flow System Accessory K-TIRF

Incorporate TIRF flow cell into a PTI QuantaMaster system by replacing the standard sample holder. It includes two reusable UV silica TIRF prisms, twenty reusable silica TIRF slides, two plastic fluidic blocks, a set of ten elastic gaskets, and a Teflon cassette holder for cleaning and chemical modification of ten TIRF slides.

Titration K-165-B

Titration is performed to measure a number of biochemical and physical parameters, including binding constants, stoichiometry and kinetics. HORIBA offers fully automated titration solutions that are integrated into the software. Parameters such as mixing, volume, speed, and calibration are dictated in the software and can be adapted to your needs.

Integrating Sphere KSPHERE-Petite

Petite integrating sphere: Easy-to-use 3.2" integrating sphere that can be installed in seconds, replacing a standard cuvette holder—no optics to change, or light guide coupling required. Easily removable top enables changing samples in seconds. It can accommodate regular cuvettes, slides and powders, with all 3 holders included.

UPCONV-980 Upconversion Kit

UPCONV-980 upconversion kit for the PTI QuantaMaster 8000 consists of a 980 nm CW diode laser and an integrating sphere. The upconversion setup allows for simple determination of the luminescence upconversion quantum yields due to an efficient and ergonomically-designed integrating sphere (shown with the top removed) with easy access to the sample area.

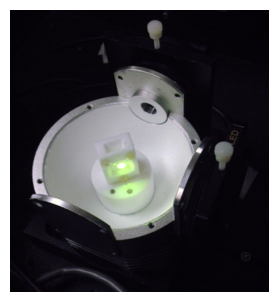

HORIBA FLUORESCENCE

Scientific

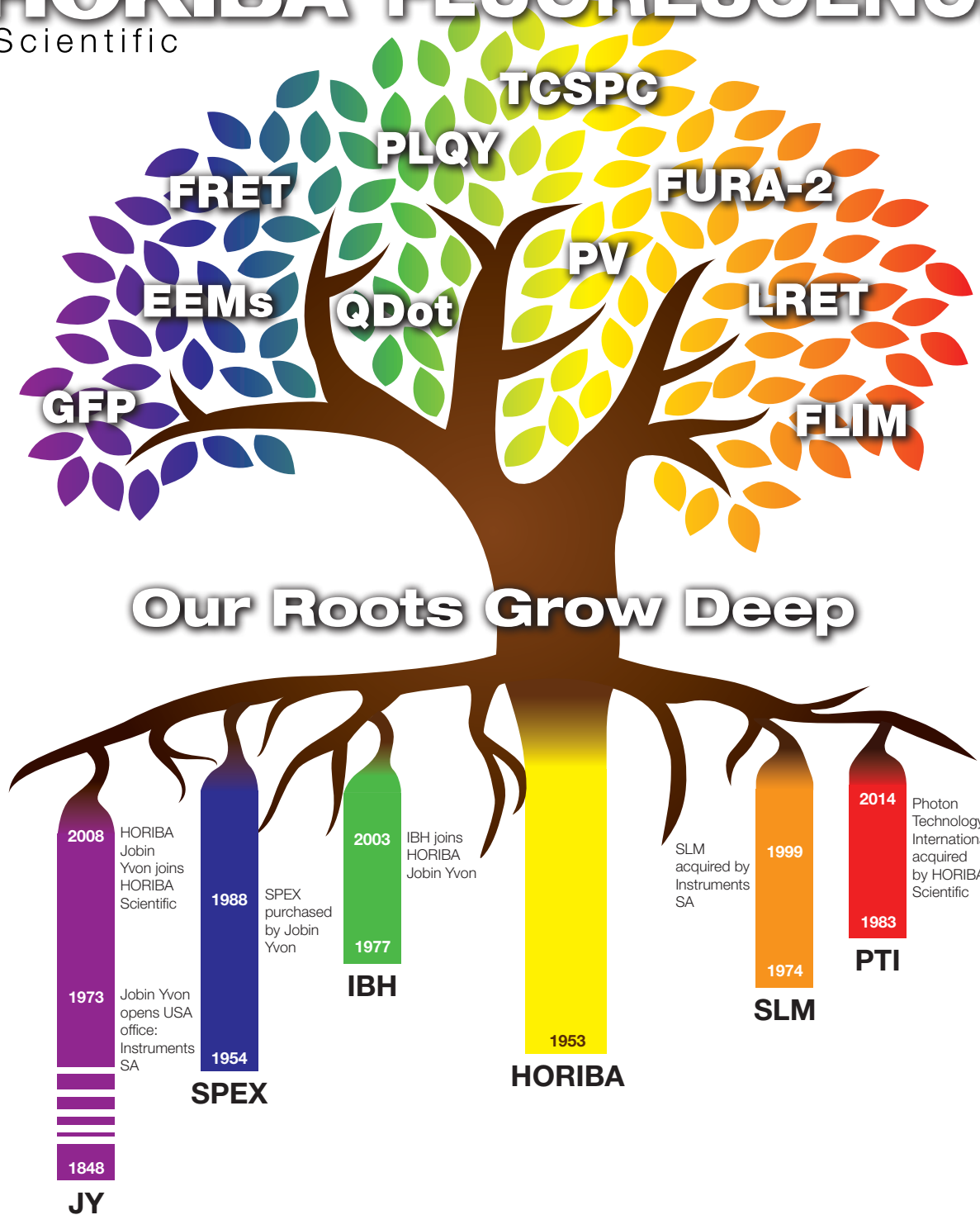

Our Roots Grow Deep

www.horiba.com/fluorescence
info.sci@horiba.com

- USA:** HORIBA Instruments Inc., 3880 Park Avenue, Edison, NJ 08820-3012 - Toll-free: +1-866-562-4698 - Tel: +1 732 494 8660 - Fax: +1 732 549 5125 - Email: info.sci@horiba.com
- France:** HORIBA Jobin Yvon S.A.S., 16-18 rue du Canal, 91165 Longjumeau cedex - Tel: +33 (0)1 69 74 72 00 - Fax: +33 (0)1 69 09 07 21 - Email: info.sci.fr@horiba.com
- Japan:** HORIBA Ltd., Tokyo Branch Office, 2-6, KandaAwaji-cho, Chiyoda-ku, Tokyo 101-0063, Japan - Tel: +81-(0)3 6206 4721 - Fax: +81 (0)3 6206 4730 - Email: info.sci.jp@horiba.com
- Germany:** HORIBA Jobin Yvon GmbH, Neuhofstraße 9, 64625 Bensheim - Tel: +49 (0)89 4623 17-0 - Fax: +49 (0)89 4623 17-99 - Email: info.sci.de@horiba.com
- Italy:** HORIBA Jobin Yvon Srl, Via Cesare Pavese 21, 20090 Opera (Milano) - Tel: +39 2 5760 3050 - Fax: +39 2 5760 0876 - Email: info.sci.it@horiba.com
- UK:** HORIBA UK Ltd., 2 Dalston Gardens, Stanmore, Middlesex HA7 1BQ - Tel: +44 (0)20 8204 8142 - Fax: +44 (0)20 8204 6142 - Email: info.sci.uk@horiba.com
- China:** HORIBA (China) Trading Co. Ltd., Unit D 1F, Bldg A, Srynnex International Park, No. 1068 West Tianshan Road, Shanghai 200335 - Tel: +86 (0)21 6289 6060 - Fax: +86 (0)21 6289 5553 - Email: info.sci.cn@horiba.com
- Brazil:** HORIBA Instruments Brasil Ltda., Rua Presbítero Plínio Alves de Souza, 645, Loteamento Polo Multivias, Bairro Medeiros, Jundiaí / SP, CEP 13.212-181 - Tel: +55 (0)11 2923 5440 - Fax: +55 (0)11 2923 5490 - Email: info.cientifica.br@horiba.com
- Other:** Tel: +1 732 494 8660 - Email: info.sci@horiba.com

HORIBA Scientific has a policy of continuous product development, and reserves the right to amend part numbers, descriptions and specifications without prior notice.