

XGT-9000 Series X-ray Analytical Microscope

Look Below The Surface



What is the XGT-9000 Series?

The XGT-9000 Series is a micro-XRF spectrometer, which provides non-destructive elemental analysis of materials.

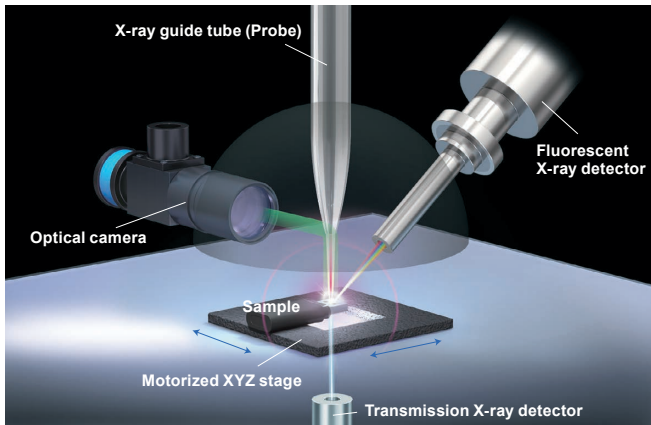

Single point, multi-points and mapping analyses can be done by one instrument.

- 1 Incident X-ray beam is guided towards a sample placed on the motorized stage.
- 2 Sample surface can be observed by the optical camera to find an area of interest on the sample.
- 3 The motorized stage moves to the measurement position once a measurement starts.
- 4 Fluorescent X-rays and transmission X-rays are detected by individual detectors.

What is XGT-9000 Pro and XGT-9000 Expert?

XGT-9000 Pro

Excellent sensitivity



XGT-9000 Expert

Ultimate sensitivity & Wide element range

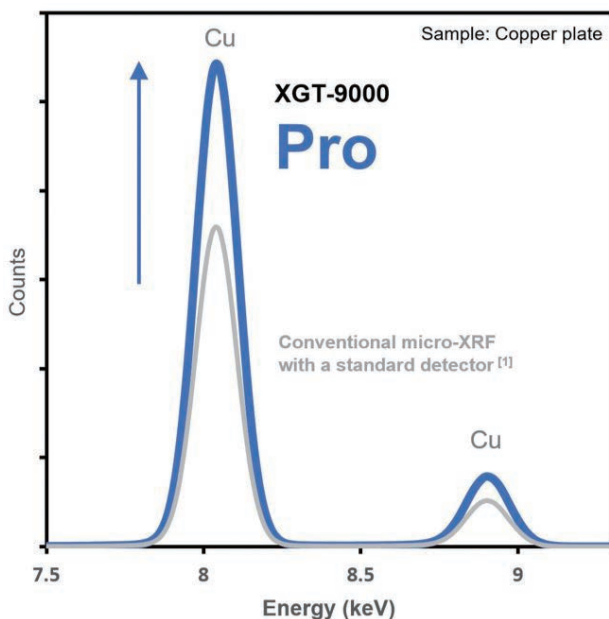

Cu intensity comparison

XGT-9000 Pro vs. [1]HORIBA conventional micro-XRF with a standard detector

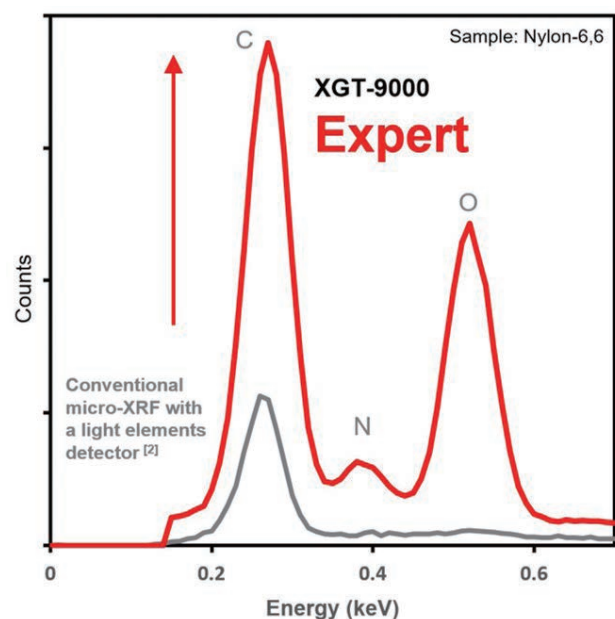

Light elements peak intensity comparison

XGT-9000 Expert vs. [2]HORIBA conventional micro-XRF with a light elements detector

Unique key features

Multi-probes including most advanced 15 μm ultra-high intensity

The XGT-9000 Series provides a wide selection of probe. Multi-probes can be installed in the instrument and switchable on the software. Two ultra-high intensity probes of 15 μm and 100 μm can be chosen.

<Multiple probes for the XGT-9000 Series to select>

- 10 μm probe
- 50 μm probe
- 100 μm probe
- 400 μm probe
- 1.2 mm probe
- 15 μm ultra-high intensity probe
- 100 μm ultra-high intensity probe

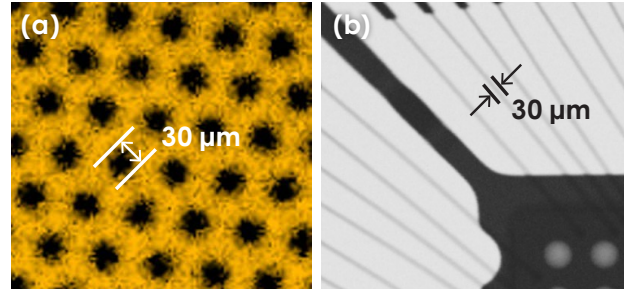

Imaging using 15 μm ultra-high intensity probe

(a) Cu image on Copper mesh with 30 μm holes
 (b) Transmission X-ray image of wire patterns inside a IC chip

Clear and flexible optical image

The XGT-9000 Series has high quality cameras with adjustable focus and advanced illumination modes.

They provide a clear view of the targeted areas of interest on a sample. The figures on the right show a small bearing with corrosion inside. Clear images can be obtained for both the surface of the bearing and the corroded zone inside.

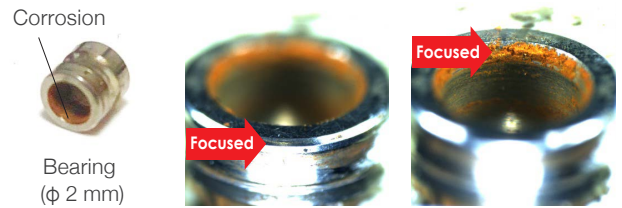

Simultaneous imaging of fluorescent X-rays and transmission X-rays

Combination of elemental images and transmission images allows one to detect hidden defects.

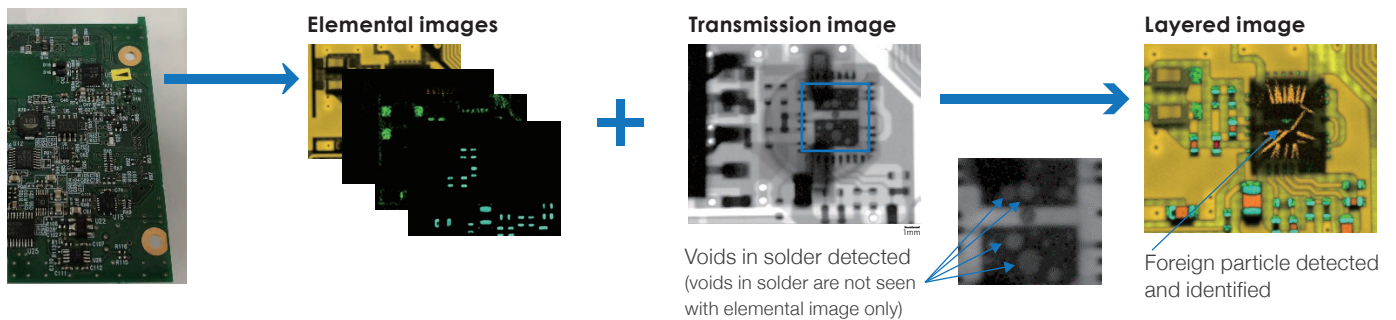

Multiple measurement environments for your analysis

Multiple measurement environments can be selected depending on the application and the nature of the investigated sample. Whole vacuum mode offers the best sensitivity especially for light elements. Partial vacuum mode allows a sample under ambient condition to be measured with enhanced sensitivity. He purge module (optional) is available.

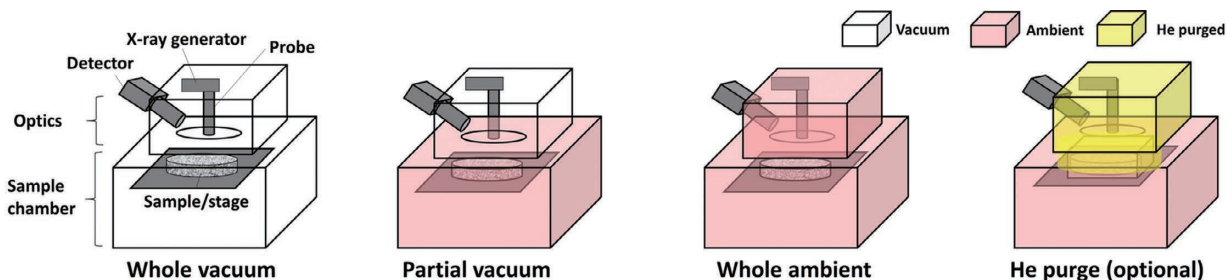

The XGT-9000 Series: Wide range of applications

Lithium-ion battery: Foreign particle analysis

The XGT-9000 Series can detect and determine the composition of foreign particles, and therefore track the source of contamination.

The particle detection function (see page 6) within the XGT-9000 Series makes it possible to count the number of particles, characterize particle sizes, and get the coordinate position of particles to re-analyze them in detail.

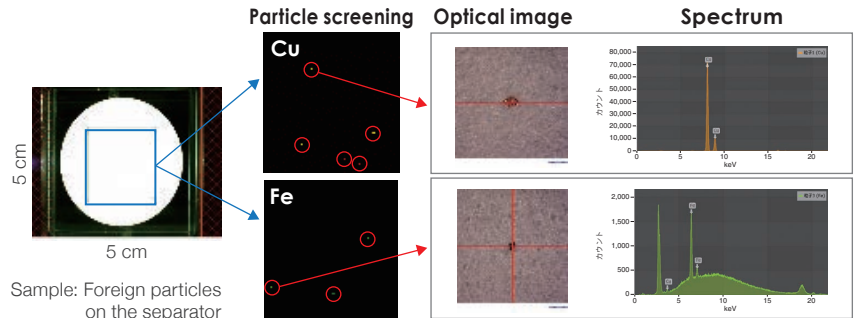

Fuel cell: Catalyst loading mass and radical quencher imaging

Proton exchange membrane fuel cell, for example, includes some inorganic elements such as radical quenchers and precious metal catalysts, and the composition and the spatial distribution play important roles in the fuel cell performance. The XGT-9000 Series allows non-destructive composition analysis and elemental distribution imaging on fuel cell materials.

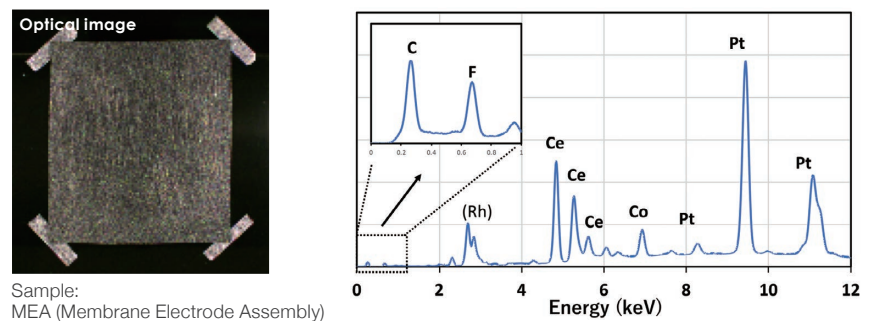

Semiconductor: Coating thickness measurement

The combination of micro-probe and thickness calculation function makes the XGT-9000 Series useful for semiconductor applications such as coating thickness measurement of narrow patterns on a wafer and coating on small electronics. Examples on the right show an optional 4-inch wafer holder and coating thickness measurement result of Au pattern on a Si wafer using calibration curve method.

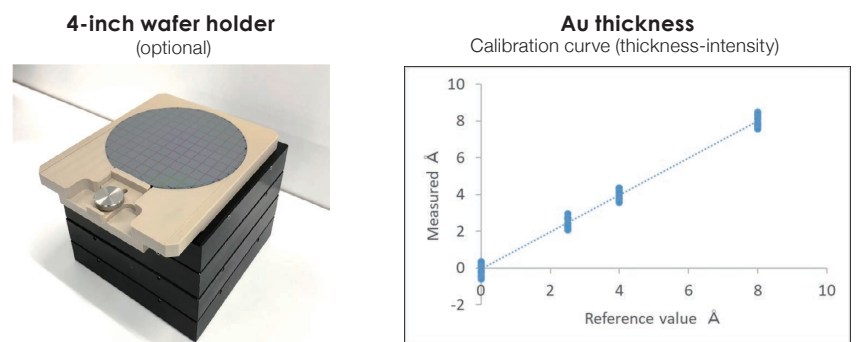

Electronics: Failure analysis, RoHS testing

Simultaneous imaging of transmission X-rays and fluorescent X-rays is effective to find defects inside electronic components (see page 3). The XGT-9000 Series is also an effective screening tool for RoHS testing. It can perform elemental mapping to find suspicious components on a complex sample and analyze them to obtain the concentration of the regulated elements. The software can display compliance with the RoHS thresholds with a pass/fail result.

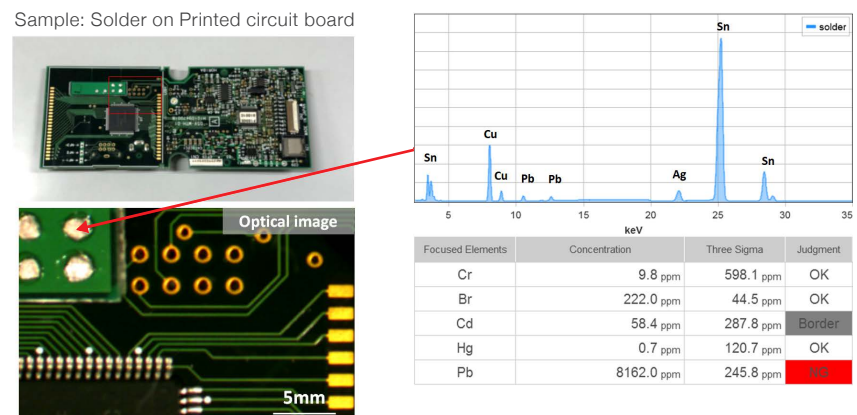

Geoscience/Mineralogy: Elemental composition identification

The XGT-9000 Series can be equipped with various probes and spot sizes providing comprehensive and detailed understanding of geological and mineral samples. Chemical phase distribution can be obtained with Labspec Link function (see page 7)

Sample: Thin section of a stone

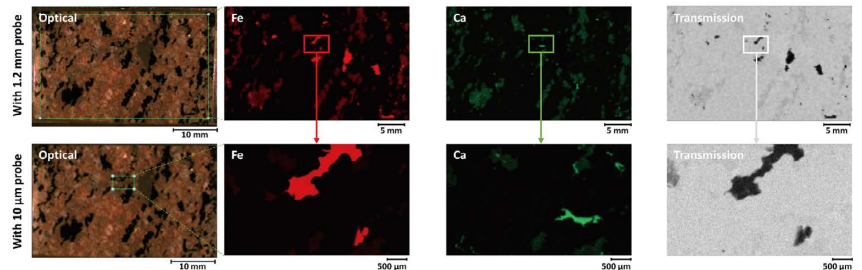

Forensic: Trace evidence identification, fake product identification

The XGT-9000 Series can be used for identification of trace evidences such as collected gunshot residues, glass fragments, and fibers with sizes even down to tens of micron. It can also be used for fake product identification.

This data shows comprehensive and detailed elemental map images of gunshot residue on a cloth with two different probes under partial vacuum condition.

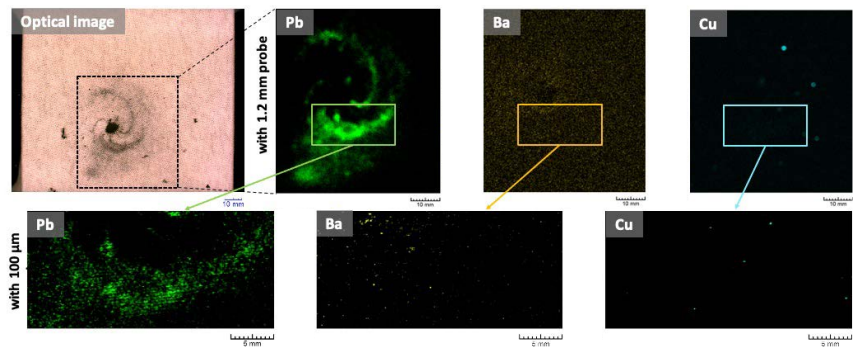

Biology: Metabolism investigation

Elemental distribution is important to understand metabolism in biological samples. Biological samples contain water or gas and therefore cannot be measured in a whole vacuum because they will be significantly affected or damaged. The unique partial vacuum mode or optional He purge mode with the XGT-9000 Series enables analysis of biological samples without compromising sensitivity to the light elements.

Sample: Fly



Spectrum comparison (He vs Air)

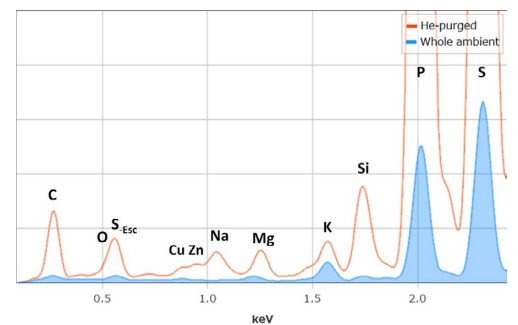

Archaeology: Origin investigation

Non-destructive elemental analysis is important for valuable archaeological samples, and the elemental information helps us determine when and where they were made. Elemental composition of a dragonfly eye bead (shown right) revealed that it originated in Egypt/Middle East during the 2nd century B.C. The XGT-9000 SL Series (super large chamber model) can fit large samples without compromising performance and X-ray safety.



Sample: Dragonfly eye bead

The XGT-9000 Series Software Suite

Simple and rich GUI/Customizable windows/Advanced functions

The user interface offers a flexible way to measure multiple samples or areas in unattended mode (queue function), display the analytical results, present the data, and edit reports. Advanced treatments include image processing, particle detection, co-localized measurement and multivariate data analysis (refer to "Combination of XRF and Raman Spectroscopies").

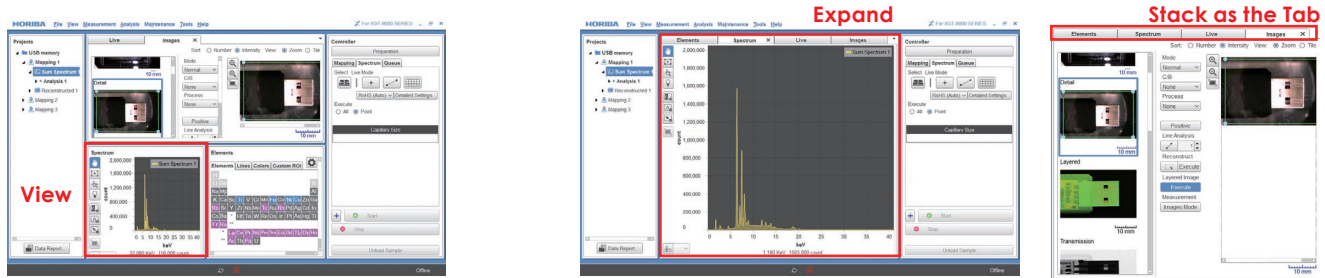

Standard GUI

Edited GUI

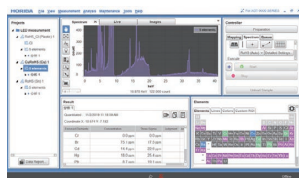

RoHS mode GUI

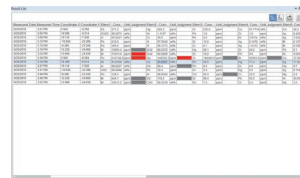

Result list view

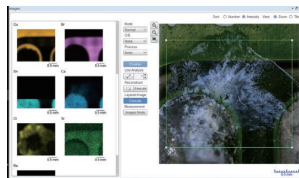

Floating view

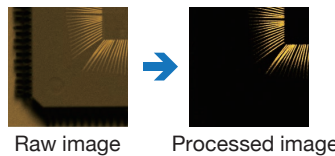
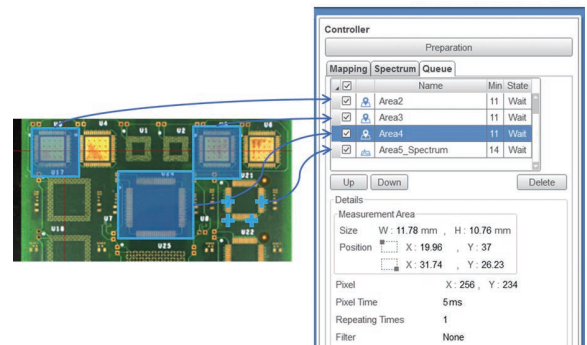

Image processing for mapping



Multiple measurements including mapping /multi points Queue function

Particle detection function

The particle detection function is available from optical image, fluorescence X-ray images, and transmission X-ray image. The particle detection function detects particles automatically and marks their position for multi-point measurement, classification and analysis.

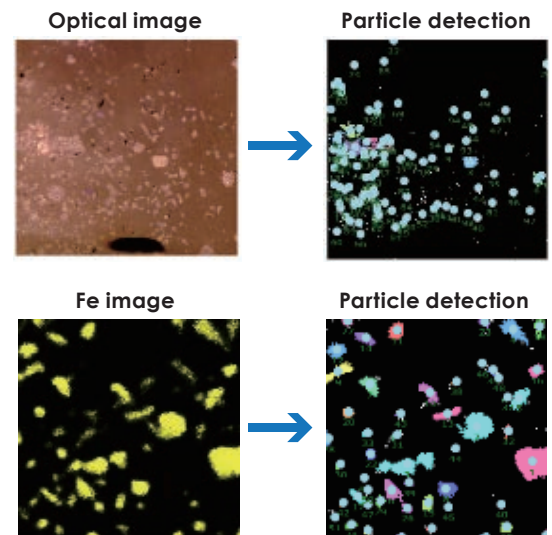
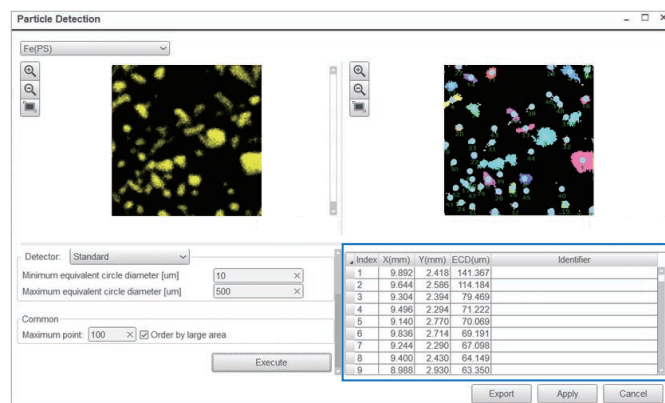

Coordinates of detected particles are automatically stored and transferred to the multi-point analysis mode.

Do more with your HORIBA XRF

Combination of XRF and Raman Spectroscopies

- ◆ XRF and Raman spectroscopies are complementary techniques.
- ◆ XRF provides information about elemental composition of the material, whereas Raman offers molecular information.
- ◆ Co-localized measurements between the XGT-9000 Series and HORIBA Raman Spectroscopy provide more information about a sample.
- ◆ Transfer of XGT-9000 Series data to the advanced LabSpec Suite software using LabSpec Link.

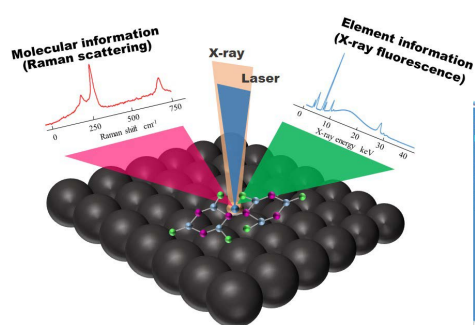

Combination of XRF

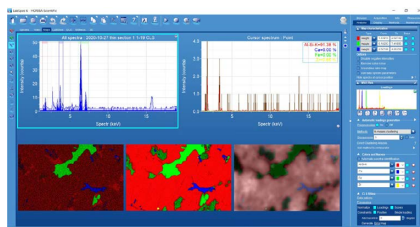

LabSpec Link

Sample holders

Various sample holders are provided to fit different shapes and types of samples. Fast and easy change between holders with HORIBA's modular stage design.



One touch sample holder



Sample tray (WR type)

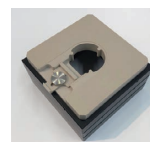

Wafer holder (2-inch, 4-inch and others)

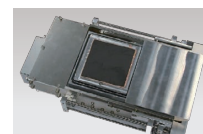
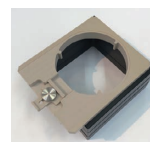

Transfer vessel
Measurement of samples isolated from air

HORIBA XRF family

XGT-9000SL Series



*1 with the door closed

HORIBA XGT-9000SL Series is an X-ray analytical microscope with a super-large chamber which allows a non-destructive analysis of your valuable large samples such as a large printed circuit board, a fuel cell sheet, a brake rotor, wafers, or archaeological samples without compromising user safety.

- Available chamber size: 1030 mm (W) x 950 mm (D) x 500 mm (H)
- Maximum mapping size: 350 mm x 350 mm on a 500 mm x 500 mm sample
- Sample environment: partial vacuum, whole ambient, He purge (optional)

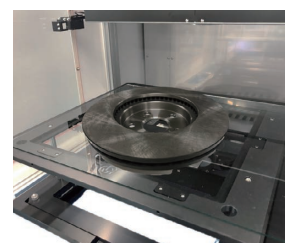

Compact XRF

Sulfur / Chlorine-in-Oil analyzer

In / On-line analyzer



MESA-50*2



MESA-50K



MESA-7220V2



SLFA-60



SLFA-6000 Series*2



Real time analyzers for coating thickness or composition



*2 These products are available in all the regions except the EU and the UK.

XGT-9000 Series Specification

Model	XGT-9000	
	XGT-9000 Pro	XGT-9000 Expert
Basic information		
Instrument	X-ray analytical microscope	
Principle	Energy dispersive X-ray fluorescence spectroscopy	
Detectable elements*	F (9) - Am (95)	B (5) - Am (95)
Available chamber size	450 mm (W) x 500 mm (D) x 80 mm (H)	
Maximum stage load capacity	4 kg	
Maximum mapping area	100 mm x 100 mm on 300 mm (W) x 250 mm (D)	
Sample observation		
Optical image observation	Two high resolution cameras	
Whole image	5 million pixels, Field of view: 100 mm x 100 mm	
Detailed image	5 million pixels, Field of view: 2.5 mm x 2.5 mm	
Optical design	Vertical-coaxial X-ray and optical observation	
Sample illumination / Observation	Top, bottom, side illuminations / Bright and dark fields	
X-ray generator		
Power	Up to 50 W	
Voltage	Up to 50 kV	
Current	Up to 1 mA	
Target material	Rh	
X-ray guide tube (Probe)		
Probe spot size selection	Various probe combination can be offered (e.g. 15 μm ultra-high intensity probe and 100 μm ultra-high intensity probe can be chosen)	
Detectors		
X-ray fluorescence detector	Liquid nitrogen-free Silicon Drift Detector (SDD)	
Transmission detector	NaI (TI)	
Operating mode		
Measurement environment	Whole vacuum Partial vacuum Whole ambient He purge (optional)	Whole vacuum Partial vacuum He purge (optional)
Instrument dimension (main unit)		
Instrument size	680 mm (W) x 860 mm (D) x 760 mm (H)	
Mass weight	Approximately 200 kg	

*Under whole vacuum condition

Dimensions (Unit: mm)

XGT-9000

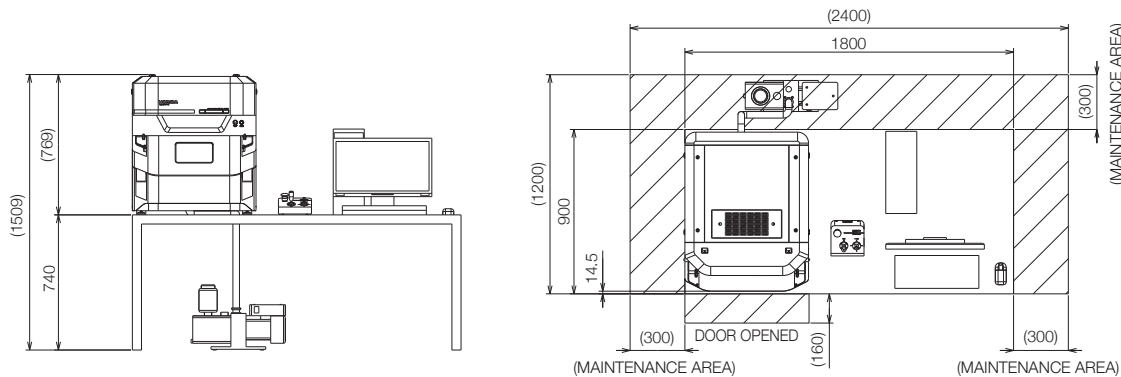

IMS

HORIBA Group is certified Quality Management System ISO9001, Environmental Management System ISO14001, and Occupational Health and Safety Management System ISO45001 and operate as Integrated Management System (IMS).



Please read the operation manual before using this product to assure safe and proper handling of the product.

- The specifications, appearance or other aspects of products in this catalog are subject to change without notice.
- Please contact us with enquiries concerning further details on the products in this catalog.
- The color of the actual products may differ from the color pictured in this catalog due to printing limitations.
- It is strictly forbidden to copy the content of this catalog in part or in full.
- The screen displays shown on products in this catalog have been inserted into the photographs through compositing.
- All brand names, product names and service names in this catalog are trademarks or registered trademarks of their respective companies.

HORIBA

<https://www.horiba.com/int/scientific/>

Japan: +81 (75) 313-8121
China: +86 (21) -6289-6060
Korea: +82 (31) 296-7911

Singapore: +65- (6) -745-8300
India: +91- (11) -4646-5000
USA: +1 (732) 494-8660

France: +33- (1) 69-74-72-00
Germany: +49 (0) 6172-1396-500