

Readout

HORIBA Technical Reports

July 2020

English Edition No. **54**

Microplastics and Nanoplastic: Analysis and Method Development

Foreword: To Protect Water Quality around the World

Guest Forum:

- Status of Legislation and Regulatory Drivers for Microplastics in California
- Context Microscopy and Fingerprinting Spectroscopy of Micro- and Nanoplastics and Their Effects on Human Kidney Cells Using NanoGPS and Particle Finder
- Microplastic Analysis in Seawater - Minimum Requirements for Comparative Data Generation

**HORIBA**

https://www.horiba.com/en_en/company/about-horiba/technical-journal-readout/



Ever since the very beginning at the end of 1945, HORIBA products have been applied to environmental applications to protect our planet, and it was only natural therefore, based on the ever increasing concern over microplastics (MP's) and nanoplastics (NP's) in our environment, that HORIBA would be closely involved in leading the development and standardization of analysis methodologies for this pervading pollutant.



Rainbow Bridge and light trail of passing vessels has been my old challenge in the genre of "Landscape photograph in big city"; and that is realized after getting difficult location and shot timing. Challenge to microplastics problem is also big concern even in this beautiful scene.

-Photographer Hideo MATSUI-
(Member of Nikakai Association of Photographers)

Name of the book

This book is named "Readout" in the hope that "the products and technology we have created and developed will be read out and so become widely known".

Microplastics and Nanoplastic: Analysis and Method Development

Foreword

- 4** To Protect Water Quality Around the World
HORIBA Dan

Review

- 6** Microplastics and Nanoplastics: Method Development and Analysis and the Relationship with HORIBA Instruments Incorporated (HII)
Andrew WHITLEY

Guest Forum

- 17** Status of Legislation and Regulatory Drivers for Microplastics in California
Scott MARTINDALE, Stephen B. WEISBERG, Scott COFFIN
- 23** Context Microscopy and Fingerprinting Spectroscopy of Micro- and Nanoplastics and Their Effects on Human Kidney Cells Using NanoGPS and Particle Finder
George SARAU, Melina YARBAKHT, Barbara E. OßMANN, Lasse KLING, Johannes AST, Florian VOLLNHALS, Janina MUELLER-DEILE, Mario SCHIFFER, Silke H. CHRISTIANSEN
- 33** Microplastic Analysis in Seawater - Minimum Requirements for Comparative Data Generation
Amy LUSHER

Feature Articles

- 37** Understanding the Nature of Microplastic Pollution and Identifying Environmental Impacts
Bridget O'DONNELL
- 47** Raman Applications on Microplastics
Eunah LEE, Bridget O'DONNELL, Andrew WHITLEY
- 54** A Focus on HORIBA European Network Activity around Microplastics
Florian FORMANEK
- 60** Microplastics Related Activities in Our HORIBA Group, Japan
NUMATA Tomoko, YAMAUCHI Susumu

Product Introduction

- 65** X-ray Fluorescence Sulfur/Chlorine-in-Oil-Analyzer MESA-7220V2
UEDA Hideo, Michael POHL
- 69** Development of the Ambient Carbon Dioxide Monitor APCA-370
NAGASAWA Kenya, MIZUNO Yusuke
- 73** Development of the WQ-300 Series Multi-digital Water Quality Meter
KOMATSU Yuichiro
- 76** Industrial Gel-Filled pH Electrode 6155
KINOSHITA Takamasa, ITO Yuichi, NISHIO Yuji, MUROGA Tatsuoki

Selected Articles

- 81** Evaluation of Infrared Thermometer for Reduction of Influence of Gas Absorption by Optimization of Spectral Response
FUJINO Sho

-
- 85** HORIBA World-Wide Network

To Protect Water Quality Around the World



HORIBA Dan

President

HORIBA Advanced Techno, Co., Ltd.,

A handwritten signature in black ink that reads "Dan Horiba".

The history of HORIBA began with the founder Dr. Masao Horiba having completed the first Japanese glass pH electrode meter in 1950. Since it is the origin of HORIBA, water analysis is the foundation of HORIBA.

In the 1960s, the desktop pH meter was evolved into a compact design. In the 1970s, the composite electrode was developed by integrating with a glass electrode, a reference electrode and a temperature compensation electrode. In the 1980s and 1990s, we developed card-type, handy-type, and stick-type products in response to different use requirements, and extended into on-line analysis. In the 2000s, the product lineup has been expanded, and our pH products have continually evolved in all aspects of accuracy, quality, and design. In addition to using electrochemistry and conductivity for water analysis, we have developed our spectroscopy technology for liquid applications, and extended water measurements on-line. We now provide a wide range of water quality analysis equipment related to environmental regulations and industrial processes on top of those for research and development.

There are various needs for water quality analysis related to environmental regulations. For example, with the tightening of exhaust gas environmental regulations on ships (Sulfur oxide SO_x emissions in general sea areas are now 0.5% or lower), however demands for water quality monitors of exhaust gas purification equipment are increasing. Sulfur oxide in exhaust gas emissions, generated from the ship internal combustion engines, has been suppressed by sprinkling scrubber water on the exhaust gas. However, this scrubber water is itself required to be treated before it is discharged outboard of ships. Our product (EG-100) is indispensable for measuring water quality at the time of water coming into the

scrubber system and after water treatment, since water can only be discharged to the outboard of the ships if it meets the regulation values set by the International Maritime Organization (IMO).

Meanwhile, in many developed countries, there is a need for improved convenience for water use so that people can realize a high standardization of water infrastructure facilities, everyday new efforts and new facilities are created to improve efficiency and protect water quality. The supply of water is not always balanced against the demand of water use in many countries of the world, and even at this moment increased water purification and water treatment facilities, systems and measurement are needed. In addition, it is expected that more countries will step up their efforts to recycle natural and industrial wastewater, and increase activities to reduce environmental impact. In some regions like North America, the reuse of wastewater and desalination will be more prevalent in certain areas like the western and southern regions where water shortages are becoming more serious. In Latin America, it is expected that more countries such as Brazil and Argentina will promote privatization of water treatment facilities which will bring it's own challenges. Moreover, in Southeast Asian countries including China and India, regulations are becoming strengthened to reduce the environmental impact as these countries advance their capabilities. There is a demand for efficient and reliable treatment, and quantitative measurements in various water treatment processes such as drinking water, sewage and industrial wastewater. We recognize the importance of our role to take a responsibility to provide reliable measurement data for water quality attributes as these global needs grow.

With respect to the realization of a sustainable society, in relation to sustainable development goals (SDG's) set by the United Nations, HORIBA also contributes to solve many social issues by using our own technologies, products and applications to address the SDG guidelines.

In addition to the issues related to “water” that have been described so far, important social issues “related to water”, such as microplastics, are now being focused on by HORIBA today. There is a concern that microplastics will not only affect the organisms living in the hydrosphere, but also the safety of our drinking water and bottled beverages. This was also taken up as an important social issue at last year's G20. To address these issues, the HORIBA Group also contributes to expert research and problem solving, centered on our Raman spectroscopy systems, which is one of HORIBA Jobin Yvon's main product areas. It is true that plastics are essential for commercial use and our daily lives, however their disposal and removal from our ecosystem must be controlled. In order to realize a sustainable society, the HORIBA Group is dedicated to provide unique analysis and measurement solutions not only for “water” but also for “solids”, such as plastics.

HORIBA believes that “protecting water quality around the world” is our mission as a water measurement professional company. We are determined to continue to be a company that will contribute to global environmental protection and industrial development around the world, in spite of the challenges we all face this year in our family and work lives due to the spread of coronavirus.

Microplastics and Nanoplastics: Method Development and Analysis and the Relationship with HORIBA Instruments Incorporated (HII)

Andrew WHITLEY

The ecological, human and marine health threat of Microplastics (MP's) and Nanoplastics (NP's) is huge and very real. In order for MP's and NP's to be accurately monitored, understood, legislated and reduced, there remains a significant amount of collaborative work needed between scientists, managers, policy makers and instrument providers such as HORIBA. Harmonized scientific method is required in order to allow legislators and agency managers to determine which issues to prioritize. In North America, HORIBA Instruments Incorporated (HII) is working closely with both scientists and federal and state government agencies. These collaborations are intended to support and develop the science and instrumentation to allow scientists and managers to achieve the directives and advances necessary to apply legislation and reduce the risks caused by MP's and NP's. This review paper explains HII's approach, activities and role in North America to support MP's and NP's analysis and method development towards eventual field monitoring devices and actionable legislation.

Introduction

Ever since the very beginning of HORIBA, including the early development work at the end of 1945 and through the very first glass electrode pH meter products in the early 1950's, HORIBA products have been applied to environmental applications to protect our planet. HORIBA found early success at the beginning of the 1960's through the automotive emission analyzer MEXA-1. Since then many of our products have been developed for environmental or related studies and applications. Today our corporate activity towards social responsibility is focused on energy, health, the environment and safety. Some key examples of these environmentally conscious products include decades of continuing innovation in FT-IR exhaust gas analyzers; our range of XRF analyzers that were applied towards the waste electrical and electronic equipment (WEEE) and the recycling of hazardous substance (RoHS) directives; and our AquaLog fluorescence Absorbance Transmission Excitation Emission Matrices (A-TEEM) spectrometer that was developed for rapid analysis of dissolved organic matter in water to allow environmental and water treatment monitoring. It was only natural therefore, based on the ever increasing concern over microplastics (MP's) and nanoplastics (NP's) in our environment, that HORIBA would be closely involved in leading the development and standardization of analysis methodologies for this pervading pollutant.

The ecological, human and marine health threat of MP's is huge and very real. It is estimated^[1] that every year 4.8 to 12.7 million metric tons of plastic waste enter our oceans. One report^[2] estimated that up to the year 2014 there were an accumulated number of MP particles, located as a global standing stock of

small floating plastic debris, ranging from 15 to 51 trillion particles, weighing between 93 and 236 thousand metric tons, which is only approximately 1% of global plastic waste estimated to enter the ocean in each year. Presumably the remaining 99% of plastic waste ends up in sediment on the ocean floor with some washing up on beaches around the world, and some amount recovered in cleaning exercises.

HORIBA Scientific's North American involvement with MP's began with the development of a close collaboration with Dr. Chelsea Rochman and her research group in 2015 at the Freshwater and Marine Ecology Department at the University of Toronto. At that time Dr. Rochman acquired the XploRA Raman microscope for her groups MP research. In 2019, a second XploRA Raman microscope was delivered to the University and installed in the laboratory of Chelsea's colleague Dr. Robert Andrews in the Institute for Water Innovation. Dr. Rochman is a leading researcher and innovator^[3] in the field of MP's, the work of Dr. Rochman's laboratory will be outlined in detail in an article by Dr. Bridget O'Donnell later in this issue of Readout.

In September 2018 the California legislature responded to the increasing threat and public concern towards MP's by enacting two new bills, as outlined below, that require quantification of MP's in various media and development of new management strategies.

Senate Bill 1422: California Safe Drinking Water Act—Microplastics^[4]

Senate Bill 1422 (Portantino, Chapter 902, California Statutes of 2018) charges the California State Water Resources Control Board (SWRCB) with developing methodologies and a strategy for monitoring and tracking the concentration of MP's in drinking water. This includes, adopting a standard definition of MP's in drinking water by July, 2020; adopting a standard methodology to test drinking water for MP's by July 2021; adopting requirements for testing and public reporting of MP's in drinking water; and accrediting laboratories to analyze MP's.

Senate Bill 1263: Ocean Protection Council – Statewide Microplastics Strategy^[5]

Senate Bill 1263 (Portantino, Chapter 609, California Statutes of 2018) requires the California Ocean protection Council (OPC) to adopt a Statewide MP's ocean and waterways strategy and report to the legislature on implementation by 2025. The bill also requires OPC to develop a prioritized plan to research and support the development of risk assessments in marine habitat by 2021. This includes, development of standardized methodologies for extracting, sampling, counting, and characterizing MP's in the environment; moving forward to characterize ambient concentrations, impacts, sources and pathways of MP's in California waterways; and developing approaches to reduce the introduction of MP's into marine environments, including source control.

With the announcement of these bills the HORIBA Scientific Business Development team, led by Dr. Kentaro Nishikata and Dr. Andrew Whitley proposed a working group meeting to review the analytical instruments and field monitoring required by these bills. We approached Dr. Rochman to discuss planning such a meeting. Dr. Rochman suggested that we collaborate

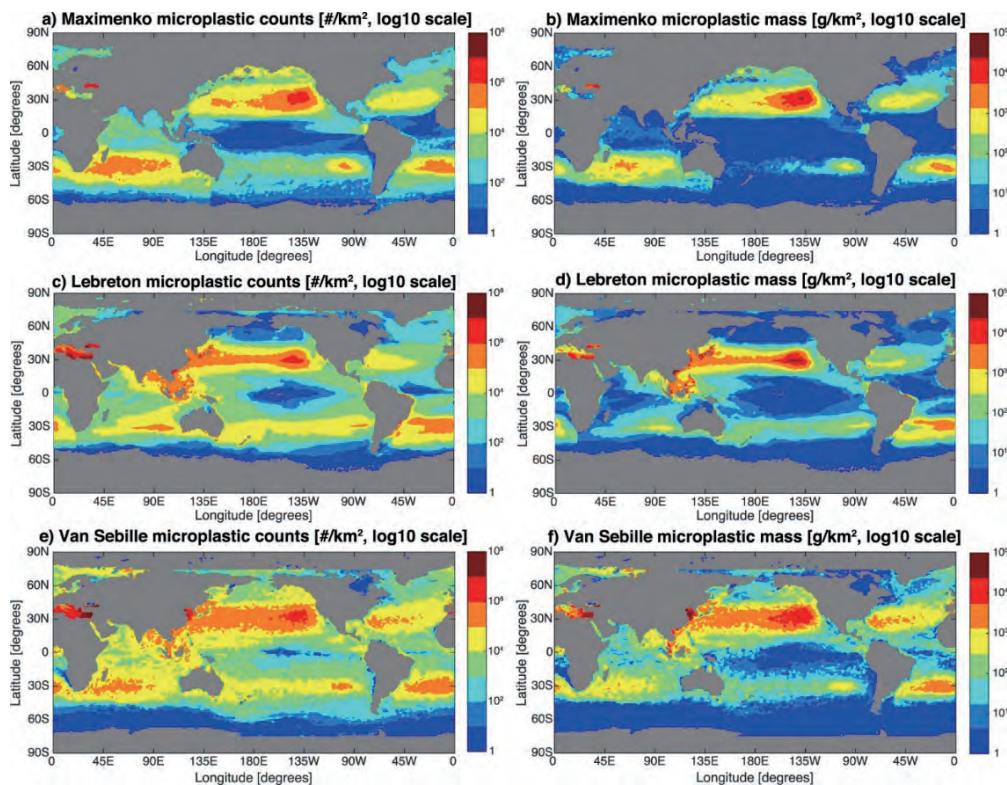

Figure 1 Maps of the solutions of MP's count (left column) and mass (right column) distribution for the three different ocean circulation models. Because fits are done on a per-basin level, there are a few discontinuities visible (e.g. South of Tasmania in the Maximenko solution, panel a)). Figure 3 from "A global inventory of small floating plastic debris". Erik van Sebille et al 2015 Environ. Res. Lett. 10 124006 doi:10.1088/1748-9326/10/12/124006^[6]

with and hold the meeting at SCCWRP in Costa Mesa, CA, which happens to be just 13 miles from the North American headquarters of HII in Irvine. Chelsea introduced us to Dr. Steve Weisberg, Executive Director of the Southern California Coastal Water Research Project Authority (SCCWRP), and together we proceeded to discuss what was required to create a successful working group meeting. It was agreed that at the meeting it would be necessary to perform a gap analysis between existing methods and summarize the necessary actions to bridge these gaps. From an analytical instrument and environmental monitoring device manufacturer point of view, HORIBA needs to work closely with the scientists and managers that are tasked with advising policy makers what instrument and method developments are needed to meet legislation, in this case the two CA Senate bills. HORIBA and other manufacturers require the measurement requirement to be strictly stated so that we can collaborate and advise on possible solutions. Where possible collaborating on method development using existing instruments, but when needed adapting hardware, including sample handling and automation, and software, to meet the measurement requirements. In some cases, where the need is extensive and fully understood, the development of new instrumentation will be done, in the case of MP's, as an example, for in field or treatment plant monitoring.

On April 4-5, 2019 our workshop: "Measuring Microplastics: Building Best Practices for Sampling, Extraction and Analysis", hosted by HORIBA, SCCWRP and the University of Toronto, in coordination with the State of California Water Resources Control Board (SWRCB) and the California Ocean Protection Council (OPC) was held at SCCWRP in Costa Mesa. The main meeting objectives were:

1. Understand policy-maker needs in regards to microplastics methods.
2. Agree on the state of the science and determine the research necessary

to reach shared goals.

3. Co-develop a manuscript on best practices for microplastics analyses.
4. Design a study plan to develop harmonized methods, including collection, laboratory and data management, for microplastics analysis.

There were 14 presentations from regulatory and legislation representatives, and scientists and managers from around the world. The meeting presentations were recorded and can be viewed via the link in this reviews references.^[7] To begin the day, we heard from Deborah Halberstadt, the Executive Director of the OPC, and Darrin Polhemus, the Deputy Director for Drinking Water at the SWRCP. They shared their perspective and the targets they need to meet which were mandated by SB1263 and SB1422. The scientific presentations were separated in to four main topics—extraction, sampling, analytical methods and data analysis. At the end of the first day, we asked everyone to think about what they had learned and what they needed moving forward in relation to their own research, monitoring or management. We asked everyone to answer four questions:

- What is your most urgent need at this moment?
- What would you like to see in a best practices report?
- What types of methods would you like to see developed?
- What are some of the key concerns that should be taken into consideration when developing/choosing best methods and practices?

The answers to these questions by all stakeholders were summarized in the final meeting report, they were used to guide day 2 of the meeting and will continue to be used to guide future work. On day 2 of the meeting our goals were to:

1. Create scientific journal review articles (for *Applied Spectroscopy*) to summarize the state of the science towards standardized MP's analysis.
2. Develop a study plan that addresses issues necessary to achieve method standardization.

First we worked on the articles for the special issue of *Applied Spectroscopy*. We spent the morning beginning drafts of each review paper that we were planning to write together and agreeing upon a general outline for the special issue. The special issue will be wrapped up in July, 2020 and come out in early Fall, 2020. Details of this special issue of *Applied Spectroscopy* can be found later in this review. The afternoon session was spent discussing the format for a multi-lab MP's methods evaluation study plan, this is detailed later in this review paper. The final results and actions of the meeting were then summarized, these were the final report detail to be shared after the meeting with all participants, the collaborative method evaluation study, a special issue in the journal of *Applied Spectroscopy*, and two scientific sessions on MP's analysis (organized by Andrew Whitley, HORIBA and Shelly Moore, SCCWRP) at the October, 2019, SciX conference in Palm Springs. There will also be a follow-up workshop at SCCWRP to share the results of the study plan and discuss how MP's may impact human health.



Figure 2 Ann-Marie Cook of the EPA presenting at the “Measuring Microplastics: Building Best Practices for Sampling, Extraction and Analysis” workshop at SCCWRP in Costa Mesa, CA

Toxicological considerations of Microplastics and Nanoplastics

The question of nanotoxicology and which types and sizes of MP's and NP's are most dangerous to human and animal health is still a very underserved research area and significantly more work is required here. It is certainly the case that certain size classifications of MP's down to a few tens of microns, whilst dangerous for wildlife and a pervading concern regarding pollution, do not offer as significant a health risk to humans as the smaller size classifications. Long term this larger size classifications, if allowed to go unchecked, could disrupt and damage marine populations with potentially huge cascading effects further up the marine food chain and on to humans. These larger particles if they are ingested and do not pass through the body can have long term health effects, in particular as they degrade they can leach hazardous chemicals in to the body of marine animals and ultimately humans. These chemicals have been shown to disrupt immune systems and negatively impact growth and reproduction. As a secondary effect MP's can also adsorb chemical contaminants on to their surface, transporting them within the environment or through a biological system. These differential surface absorbents, including biofilms, and particle transformations will impact MP and NP transport and toxicity. This subject is covered in more chemical detail by Dr. Bridget O'Donnell later in this issue of Readout.

The effects of MP's become much more pronounced the smaller the particles are, as they are more likely to pass from the gut and stomach to the bloodstream and other organs. As they become smaller in size these particles also can become airborne. It is known that MP's smaller than 25 microns can enter the human body through the nose or mouth and those less than five microns can end up in lung tissue.^[6] Increasing the urgency to understand the impact of airborne MP's and NP's is critical. There is already a great deal of concern, research and attempts at legislating fine particulates in the air formed by

burning fossil fuels, including black carbon or soot. These particles have been linked to a number of health impacts including respiratory issues, heart attacks and the impairment of neurological function.^[9] Most countries have air pollution standards to limit the volumes of particles less than 10 microns, and especially those below 2.5 microns, respectively known as PM 10 and PM 2.5 standards.^[10] However little has yet been done to understand the toxicity or to monitor and legislate the potentially more harmful airborne MP's and NP's pollution.^[11] The size of a particle directly relates to the surface area-to-mass ratios. The surface area-to-mass corresponds to the amount of surface area of an object (particle) within a given volume or collection of particles. The fact that NP's have a larger surface area-to-mass than MP's therefore provides a greater surface for biological contact or chemical adsorption. NP's are also more likely to become surface charged, functionalized and therefore have a further likelihood to have species chemisorbed on their surface. Such surface modifications can aid transport across organ membranes. It is known that surface modification, if cationic, can aid bonding to the brains endothelial cells and therefore become a mechanism to endocytosis and transport across the blood brain barrier. It is established that NP particles can cross biological membranes and influence cellular signaling, however, the cellular and toxic effects of these exposures have yet to be evaluated. Future studies must also identify environmentally and health risk relevant concentrations and take into account the NP physicochemical properties of each NP type analyzed. It is critical that these studies take place rapidly to help guide the necessary development of monitoring and analysis methods to target the most critical size range and MP and NP types that requires the strongest and most urgent legislation.

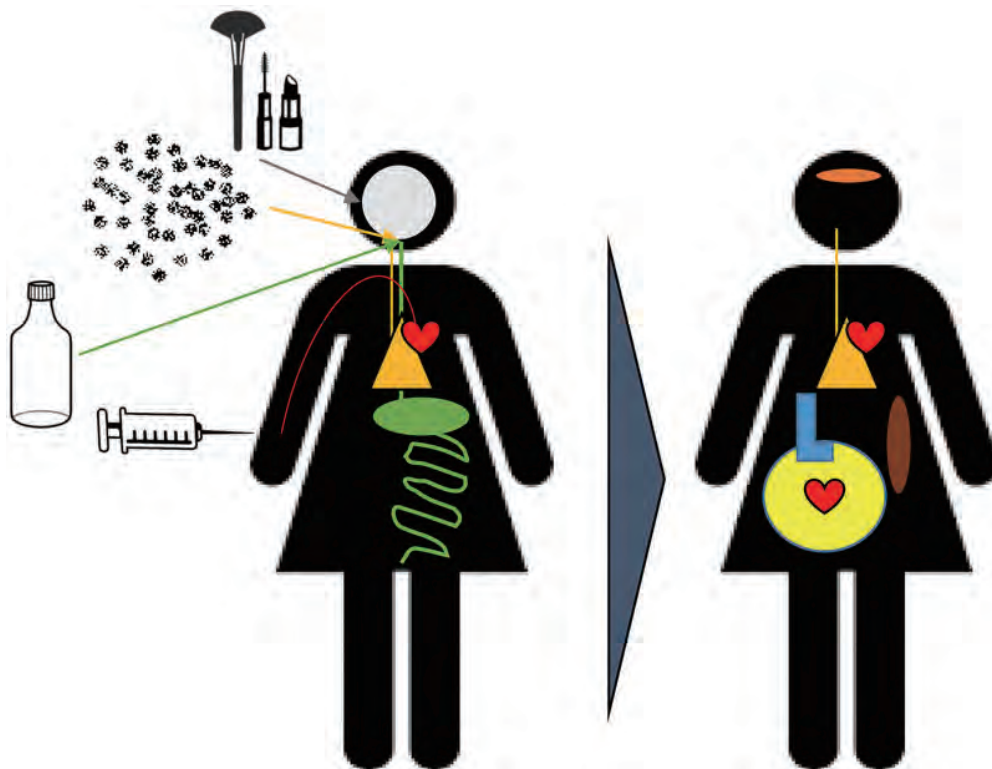

Figure 3 Diagram depicting the routes of NP's exposure (i.e., ingestion, inhalation, dermal, and injection), potential primary systems of impact, and potential secondary toxicity associated with particle deposition. *Reproduced by permission from PA Stapleton, AIMS Environ Sci. 2019; 6(5): 367–378.^[12] Published online 2019 Oct 22. doi: 10.3934/environsci.2019.5.367*

Analytical Methods for the Analysis of Microplastics

As part of the Applied Spectroscopy special issue on MP's there is an excellent review paper that compares the various analytical techniques used to identify MP's. This review paper^[13] "Critical Assessment of Analytical Methods for the Harmonized and Cost-Efficient Analysis of MP's" by Primpke et al includes a contribution by HORIBA's Dr. Bridget O'Donnell. The main focus of this comprehensive review paper is the currently applied identification and quantification tools for MP's. The authors evaluate these techniques and the need to provide a harmonized guideline for future SOPs to cover legislation like the two recent California Senate bills discussed above. The main techniques used for MP's are covered in this paper, these are naked eye detection, general optical microscopy, the application of dye staining—typically Nile Red, flow cytometry, Fourier transform infrared (FT-IR) spectroscopy and microscopy, Raman spectroscopy and microscopy and thermal degradation by pyrolysis—gas chromatography—mass spectrometry (py-GC-MS) as well as thermo-extraction and desorption gas chromatography—mass spectrometry (TED-GC-MS). A guideline to provide the necessary method harmonization in the time frames necessary to support legislation is provided. This includes an analysis of the cost of each method ranging from low cost towards higher analytical demands to measure MP's in an effective way by field laboratories and governmental institutions while maximizing information for risk assessment. It is important to achieve the goals of the California Senate Bills that we create analysis methods that are not only achievable by the most proficient experts, but ones that are transferable and repeatable among a wide array of laboratories, some of which will be introduced to MP's for the first time as a result of new legislation. Methods must also fit in to the requirements of any laboratory accreditation program to ensure the data generated are correct, consistent and traceable. The ability of the current analysis methods to meet all these requirements are being tested through the SCCWRP study plan discussed below. At HORIBA we will use the results of this study plan, our many ongoing MP collaborations and discussions with other government institutions like the EPA, NIST and ASTM to develop rugged, reproducible automated instrumentation and methods.

In Dr. O'Donnell's review of the research work of Dr. Rochman's laboratory she notes that in the characterization of MP's no single technique works for all samples encountered. It is important to use multiple tools to be able to confidently identify all or most collected particulates. This being said it has been shown and reviewed in the paper by Primpke et al that Raman microscopy does offer a number of significant advantages over other techniques. One of the most important advantages of Raman microscopy is that the spatial resolution is excellent, down to one micron or less. FT-IR microscopy typically has a spatial resolution of between 10-20 microns, and as we discussed above it is the smaller MP's that provide the largest threats to human health. In Dr. Lee's paper, in this issue of Readout, she discusses the optimum instrument and experimental configuration for MP's analysis. Dr. Lee also reviews some of our North American collaborations on MP's. It is clear from these collaborations in North America, and globally, that in order for there to be statistical relevance in studies of the number and distribution of MP's a huge amount of samples need to be analyzed. A single filtered sample of 5 liters of water can capture 1000's of particles. There is clearly a need for automated analysis. Dr. O'Donnell and Dr. Lee show in their papers how HORIBA has worked with researchers to extend development of our Particle Finder software to start to

provide a fully automated analysis of filters containing MP's. Using the XploRA Raman microscope and Particle Finder software from HORIBA, researchers can automate the location, particle characterization and identification of MP's of their filtered samples.

Now that the measurement hardware and software is starting to be available it is critical to develop standardized measurement methods. MP management strategy requires monitoring to assess the relative contributions of multiple MP sources and assess the progress toward source reduction. Such assessments are of little value if they are confounded by incomparability of measurements among different groups, sample types or over time.^[14] Placing results from North America into context of other locations is critical, but only if methods across geographies are consistent enough to warrant such comparisons. It is with this challenge of method harmonization in mind that, at the MP workshop at SCCWRP, see above, it was agreed to undertake an ambitious study plan called "Microplastic Measurement Methods Evaluation Study". The purpose of the study is to assess the consistency of a measurement, characterization and identification of MP's in a number of sample types. The study plan will assess the repeatability of results across a large number of laboratories. The study includes evaluation of five methods (stereomicroscope, staining with Nile Red, FT-IR, Raman and Pyrolysis GC/MS) applied to drinking water, wastewater, sediment and fish tissue matrices. Extraction methods to be assessed include filtration for clean water, peroxide oxidation for wastewater, density separation for sediments and KOH digestion for fish tissue. Each participating laboratory will be given a sample with known blind materials and a standard operating procedure (SOP) for the methods they have agreed and signed up to perform. Most of the expert speakers at the workshop agreed to participate in the study, but other groups have been invited across a range of laboratories, from novice to professional. The proposed timelines for the study

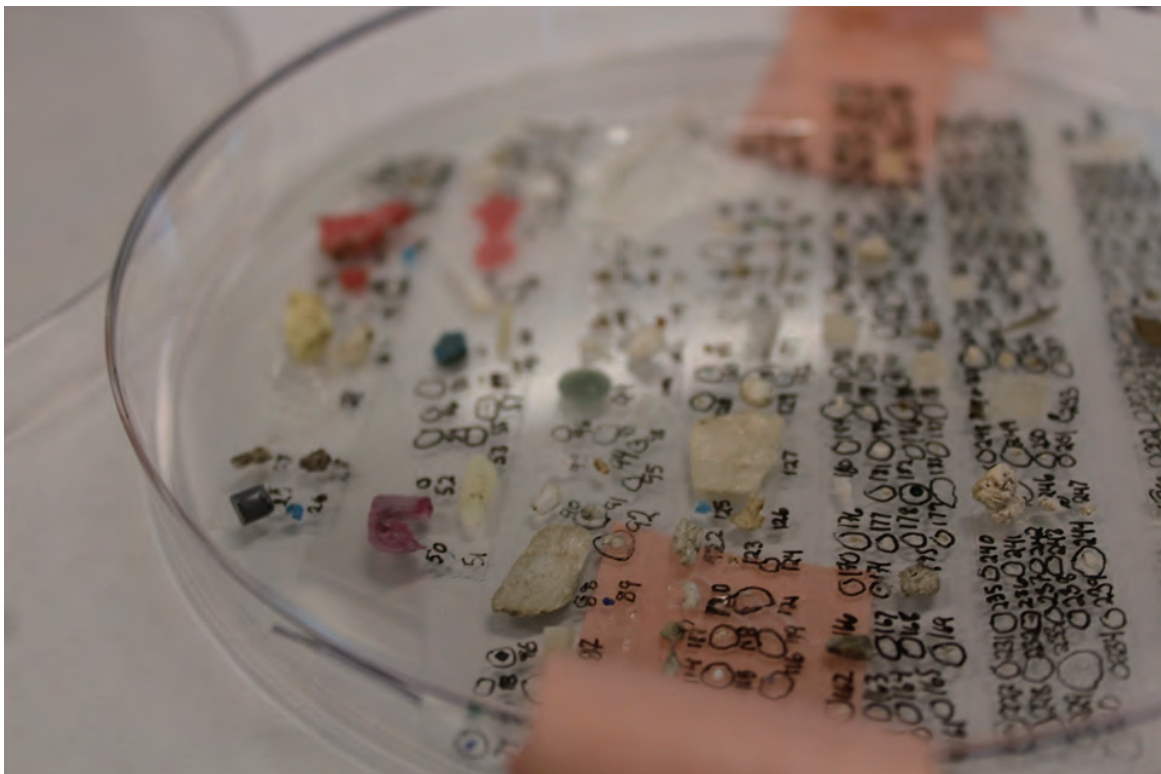

Figure 4 Examples of picked MP particles from a subset of a single experiment showing the large quantity and variation of particles that can be generated in MP analysis studies. Image reproduced by permission from the Rochman group.

plan were pushed back to late 2020 due to initial challenges to prepare the samples and then because of the COVID-19 outbreak in the Spring of 2020. The HORIBA, NJ Lab will participate in this study, along with 35 other laboratories around the world.

Thanks to the high spatial resolution of Raman microscopy it can be used to study MP's and NP's across a wide size range from around 0.5 microns, an order of magnitude less than the lower size definition of MP's, up to, and beyond, the 5 mm upper size limit definition of MP's. Dr. O'Donnell and Dr. Lee recommend, and have developed, a varied menu of Raman applications methods to be used for the various size classifications of MP's and NP's and for the different morphologies of these particles. It has also been found that in order to maximize the number of particles that can be identified with Raman spectroscopy it is important to have both a 532 nm and 785 nm excitation laser for the analysis. Some particles will also burn under a focused laser, as used in Raman spectroscopy, in these cases it is important to be able to lower the laser power by accessing the laser control through the Raman software or by using neutral density filters to control the laser power reaching the sample.

Future Microplastics business opportunities for HORIBA

There are many institutes and industries that will likely need to monitor MP's and NP's due to legislation in the near future. Apart from the more obvious monitoring requirements for environmental water monitoring, waste water treatment plants and public water plants, there are other industries that will likely be subjected to regulations. These industries include packaged water, beverages and food. Even though there have been reports on MP's in drinking water, there have been no large scale studies on quality control of packaged water and beverages for MP's. It will become, however, most likely mandatory once regulations and reproducible methods are in place. Many companies will have to acquire an analytical instrument or use an accredited analytical service. Proactive companies such as Pepsi and CocaCola have already participated in MP's workshops, and expressed interests in having access to MP counting, characterization and identification capabilities.

The challenge and opportunities long term will be to monitor MP's in flow. One such method that could be adapted and applied to this challenge is flow cytometry, this technique was originally utilized for counting and characterizing cells to monitor growth, degradation, or aggregation processes, for example protein aggregation. The sample is typically diluted by a sheath fluid and transported into a flow cell. Once in the flow cell the cells or particles scatter light from a laser beam and are counted based on changes in the optical signal in a forward or side scattering angle. Utilizing different lasers and dye staining methodologies allow for size, quantity, and distribution to be quantified, especially when combined with a strong camera for imaging. Typical size ranges of analyzed objects are between 0.5 and 50 microns.

Another approach for analyzing particles in the range of 2 microns to 1 mm in flowing solution is flow imaging. Here the diluted sample is monitored by a camera system combined with a microscope unit and each particle passing the camera is digitally imaged. The advantage of this technique over flow cytometry are that it visualizes and counts single particles with the options to later validate the counts, removing outliers like bubbles. There are also field deployable units that can be put in the field or treatment plants. In all case of

in flow monitoring of MP's pre-filtration and purification will most likely be necessary prior to analysis.

In the case of NP's there is promise that the HORIBA ViewSizer could be used to characterize and count these particles. The ViewSizer tracks scattering from individual particles to determine particle size distribution and concentration. This technique commonly known as nanoparticle tracking analysis (NTA) or particle tracking analysis (PTA). The instrument uses three lasers to simultaneously illuminate the sample and a color video camera for detection, allowing it to analyze the broad size distributions encountered with plastic^[15] NP's. Such broad size distributions cannot be analyzed by other single laser systems on the market. Furthermore, there is the potential to discern plastic NP's from other NP's with the use of an appropriate dye such as Nile red. The ViewSizer can be configured to monitor only fluorescent particles and thereby analysis specificity is limited only by the selectivity of the dye. Interest in this technique will grow as concerns about plastic NP's in the environment and NP toxicity converge.

Conclusion

In order for MP's and NP's to be accurately monitored, understood, legislated and reduced, there remains a significant amount of collaborative work needed between scientists, managers, policy makers and instrument providers such as HORIBA. Harmonized scientific method is required in order to allow legislators and agency managers to determine which issues to prioritize. Legislators have great interest in ensuring that there are measurement methods and programs that characterize risk, however it is up to the scientists and managers to determine the specific techniques that are used to achieve the risk assessment and drive policy. HORIBA has an important role to play to develop laboratory instrumentation and methods that allow scientists and managers to achieve the directives of the legislative. Eventually HORIBA's experience and expertise in environmental monitoring systems can help drive and provide for the provision of field deployable monitoring devices for MP's and NP's in liquid and air. Ultimately these tools will be able to support strategies aimed at removal of MP's and NP's at the source, removal in the transport system and ways to remove materials from the ambient environment. Finally it is likely that such tools will be used to monitor imposed limitations on producers that would affect the chemical nature of the source material. HORIBA's intent in North America is to continue collaborations with scientists and management groups to understand the most urgent laboratory instrument and field monitoring system needs to enable harmonized method development. HORIBA has an important role to play in the environmental understanding, control and reduction of the risks caused by MP's and NP's now and in the future.

Acknowledgments

Many thanks to Dr. Bridget O'Donnell, Dr. Eunah Lee and Dr. Jeff Bodycomb of HII, NJ for their valuable input and discussion during the preparation of this review paper.

* This content is based on our investigation at the year of issue unless otherwise stated.

References

- [1] JR Jambeck, R Geyer, C Wilcox, TR Siegler, M Perryman, A Andrady, R Naray, *Science* 13 Feb 2015: Vol. 347, Issue 6223, pp. 768-771, DOI: 10.1126/science.1260352
- [2] A global inventory of small floating plastic debris: Erik van Sebille et al, *Environmental Research Letters*, Volume 10, Number 12, December 2015
- [3] <https://rochmanlab.files.wordpress.com/2018/09/rochman-et-al-2017-editorial.pdf>
- [4] https://leginfo.legislature.ca.gov/faces/billTextClient.xhtml?bill_id=201720180SB1422
- [5] https://leginfo.legislature.ca.gov/faces/billNavClient.xhtml?bill_id=201520160SB1263
- [6] Erik van Sebille et al, A global inventory of small floating plastic debris, *Environ. Res. Lett.* 10 124006 (2015) <https://iopscience.iop.org/article/10.1088/1748-9326/10/12/124006/pdf>
- [7] <https://www.sccwrp.org/about/research-areas/additional-research-areas/trash-pollution/measuring-microplastics-workshop/>
- [8] PA Stapleton, *AIMS Environ Sci.* 2019; 6(5): 367–378. Published online 2019 Oct 22. doi: 10.3934/environsci.2019.5.367
- [9] Air Quality Guidelines, Global Update 2005, World Health Organization (2006); <https://laqm.defra.gov.uk/public-health/pm25.html>
- [10] Air Quality Guidelines, Global Update 2005, World Health Organization (2006); <https://laqm.defra.gov.uk/public-health/pm25.html>
- [11] Airborne microplastics: a review study on method for analysis, occurrence, movement and risks Christian Ebere Enyoh et al, *Environmental Monitoring and Assessment* volume 191, Article number: 668 (2019)
- [12] PA Stapleton, Toxicological considerations of nano-sized plastics, *AIMS Environmental Science*, Volume 6, Issue 5, 367–378 (2019) <https://www.aimspress.com/fileOther/PDF/environmental/Environ-06-05-367.pdf>
- [13] S Primpke et al, Applied Spectroscopy Special Issue on Microplastics. “Critical Assessment of Analytical Methods for the Harmonized and Cost-Efficient Analysis of Microplastics”, express published on line on April 6, 2020. DOI: 10.1177/0003702820921465
- [14] C.M. Rochman, F. Regan, R.C. Thompson. “On the harmonization of methods for measuring the occurrence, fate and effects of microplastics.” *Anal. Methods*. 2017. 9:1324-1325.
- [15] D. Stramski, J. Tatariewicz, R. Reynolds, M. Karr US Patent US9645070B2, “NANOPARTICLE ANALYZER”



Andrew WHITLEY, Ph.D.

Vice President of Sales and Business Development
Global Director of Business Development
HORIBA Instruments Incorporated (HII)

Status of Legislation and Regulatory Drivers for Microplastics in California



Scott MARTINDALE

Southern California Coastal Water Research Project Authority, Costa Mesa, CA



Stephen B. WEISBERG

Southern California Coastal Water Research Project Authority, Costa Mesa, CA



Scott COFFIN

California State Water Resources Control Board, Sacramento, CA

Microplastics are pervasive in the environment, with biological communities exposed to microplastics particles on a continuous basis. Although health risks of microplastics exposure are poorly understood, microplastics have the potential to bioaccumulate through food webs, to serve as an exposure pathway for other contaminants that have stuck to them, and – in the case of smaller microplastics – to translocate into tissues and organs. To comprehensively assess exposure risks, scientists first need to build a foundational understanding of their occurrence and fate in the environment. California is at the forefront of international efforts to vet, standardize and implement measurement techniques that will become part of routine management monitoring. A long legacy of regulatory actions on trash pollution of all kinds has optimally positioned California to serve in this leadership role, including development of the nation’s first TMDL (total maximum daily load) regulatory actions to reduce trash in waterways, as well as numerous trash source-control measures. In 2018, the California State Legislature passed a pair of bills that require the State to develop microplastics management strategies for both drinking water and California’s coastal ocean. The legislation has become a call to action for the international scientific community to develop clear, actionable recommendations supporting California’s microplastics management strategy. Already, a yearlong study has been launched to compare and evaluate various methods and instruments for measuring microplastics levels in water, sediment and tissue matrices. The study will pave the way for California to craft comprehensive, science-informed approaches for effectively managing microplastics in diverse aquatic systems.

Introduction

Numerous studies in recent years have put a spotlight on the pervasiveness of microplastics in the environment. Microplastics have been documented in waterways, in the ocean, in food and drinking water, in the atmosphere, in rain and snow.^[1] A wide variety of industrial and consumer goods - from pharmaceuticals to synthetic fabrics - contains microplastics; furthermore, larger plastics break down over time into smaller microplastic particles. Plastic pollution is growing at an exponential rate. Every minute,

the equivalent of one garbage truck’s worth of plastic escapes into the environment.^[2] Although about 14% of all plastic produced worldwide is collected for recycling, plastic pollution is expected to triple by 2060 in the absence of management intervention.^[3] The exponential accumulation of microplastics in aquatic environments is a growing management concern. Both wet- and dry-weather runoff are responsible for funneling vast quantities of microplastics into the coastal ocean and other water bodies.^[4] Microplastics also can evade wastewater treatment processes and get discharged into the coastal

ocean and other water bodies.^[5]

Although the health implications of microplastics exposure are poorly understood, both terrestrial and aquatic biological communities are being exposed on a continuous basis. Animals ranging from tiny ocean filter feeders to humans are inadvertently absorbing, breathing and consuming microplastics.^[1] Furthermore, many animals cannot distinguish microplastics from food, creating the potential for satiation challenges.^[6] Once microplastics enter food webs, they can bioaccumulate and ultimately end up in sportfish consumed by humans and wildlife.^[7] Compounding the bioaccumulation challenge is that chemicals and pathogens can stick to microplastics, creating a potential exposure pathway for multiple types of contaminants.^[8] Finally, emerging research shows that the smallest microplastics can penetrate cell membranes and translocate into tissue and organs; however, little is known about what health risks these microplastics may pose.^[9]

A foundational challenge of assessing health risks from microplastics exposure is that many microplastics are difficult to measure and track in the environment. Although microplastics are typically defined as any plastic particle less than 5 millimeters in diameter, the vast majority of microplastics in the environment are so small that they can only be seen with the aid of a light microscope or even more powerful instrumentation.^[10] These smaller microplastics can be difficult to distinguish - visually and/or sometimes spectroscopically - from non-plastic particles with similar physical and chemical characteristics, creating the potential for either under- or over-estimation.^[11]

To comprehensively assess the health risks of microplastics exposure, scientists first need to define what constitutes a microplastic particle, so they can focus on developing methods to optimally measure this form of pollution. Although scientists have studied microplastics since the 1960s,^[12] international consensus has not yet been reached on a definition.^[13] Unlike most-water quality contaminants that are typically dissolved, microplastics are particles with defined solubility, size, shape and chemical composition criteria that are found in various possible combinations in the environment.^[14] In June 2020, the California State Water Resources Control Board (State Water Board) adopted an official definition of microplastics for its drinking water program: “Solid polymeric materials to which chemical additives or other substances may have been added, that have at least three dimensions that are greater than 1 nanometer and less

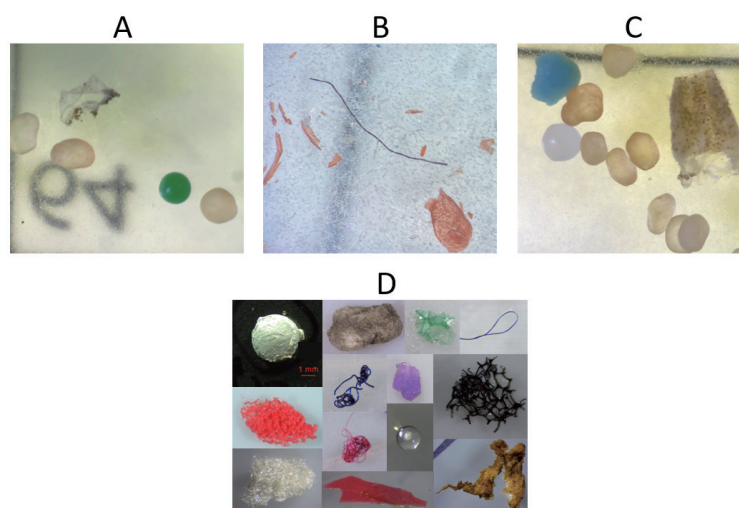

Figure 1 Microplastics are found in various shapes, sizes, colors, and polymer types in the environment. Plastic particles can be difficult to distinguish visually under a light microscope from natural particles (A-C), and may require confirmation of material type using more powerful instrumentation. (A) Microplastic spheres appear similar in shape and size to sand particles; in this case, they are differentiated by color. (B) A dark blue plastic fiber appears next to undigested pieces of fish tissue. (C) Although some microparticles are obviously plastic (blue fragments), other particles could be white sand or gelatin, and may require further spectroscopic identification. (D) Microplastic particles include spheres, fragments, fibers, foams, pellets, film, and fiber bundles. (Photos courtesy of Southern California Coastal Water Research Project Authority and C.M. Rochman, University of Toronto)

than 5,000 micrometers.” Polymers that are derived in nature that have not been chemically modified (other than by hydrolysis) are excluded under this definition.^[15] The adopted definition considers the vast diversity of microplastics found in the environment, and is likely to serve as a foundation - or at least departure point - for additional agencies and organizations that must define microplastics.^[16] Finally, the adopted definition may evolve over time with the science.

Scientists will use this agreed-upon definition of microplastics to build a foundational understanding of the occurrence and fate of these pollutants in the environment. By building comprehensive, high-quality data sets, California will gain critical, baseline knowledge of realistic exposure scenarios. However, assembling these data sets will be a challenge, as microplastics monitoring programs are still in their infancy. Even in drinking water systems - where dozens of chemical contaminants are monitored - microplastics are not one of the contaminants that are routinely tracked.^[17] Furthermore, monitoring data are not necessarily comparable even among the monitoring programs that do exist, as different programs use different, competing microplastics monitoring and analysis methods. The broader scientific community has not yet vetted any of these experimental laboratory measurement methods or reached consensus on how to standardize them.

California as an international leader on trash management

California is emerging at the forefront of international efforts to vet and standardize microplastics measurement techniques. Not only is California evaluating the performance of the various methods used to identify and quantify microplastics, but the State is working to build capacity to begin monitoring microplastics in water, sediment and tissue. This foundational work will pave the way for scientists to begin reliably measuring and tracking microplastics levels and types in aquatic environments - and ultimately generate the high-quality, comprehensive data sets needed to inform human and ecological health risk assessments.

A long legacy of regulatory actions on trash pollution of all kinds has optimally positioned California to step into an international leadership role in developing capacity to monitor microplastics in aquatic environments. For decades, California has been taking forward-thinking, decisive regulatory actions to curb the entry and spread of trash in the environment, as well as to manage and mitigate the health risks of trash.^[18] Much of this work has been borne out of necessity - a consequence of California's population density and the ecological and economic importance of the state's many natural resources. Initially, California's focus was on eliminating macro-sized trash generated by those who frequent beaches and other recreational water bodies. Beachgoers, boaters, anglers and businesses have been targeted with strict anti-littering laws, public education initiatives and outreach campaigns.

Then, in the mid-1990s, the Los Angeles Regional Water Quality Control Board led the state - and the nation - in dramatically rethinking how to curb trash entering waterways.^[19] Instead of regulating trash loading one municipality at a time, the L.A. Regional Board placed multiple key waterways in the region on the federal 303(d) list of water bodies with known water-quality impairments. This action enabled the water-quality agency to issue a regulatory target for trash known as a total maximum daily load (TMDL); the TMDL compels the many municipalities and other entities that discharge runoff into these waterways to reduce trash loading. TMDLs for trash have subsequently been issued in other parts of California and beyond.

About 15 years later, seeking to build comparable regulatory infrastructure at a statewide level, the California State Water Resources Control Board amended the master plans that govern management of California's coastal ocean and freshwater systems to include trash as a water-

quality impairment. Similar to the L.A.-area trash TMDLs, the State's "Trash Amendments" - which went into effect in 2016 - compel agencies that discharge runoff in areas with high trash-generating rates to either begin installing devices at storm drain inlets to capture all particles larger than 5 mm, or develop an alternate plan for capturing trash at equivalent rates.^[20]

As it has become increasingly clear plastic pollution makes up the majority of aquatic trash, California also has targeted plastic pollution specifically. In 2014, California voters approved a statewide ban on carry-out plastic bags at grocery stores and pharmacies.^[21] The law went into effect two years later, following an unsuccessful referendum to overturn the ban. In 2018, California passed a law requiring sit-down restaurants to only distribute single-use plastic straws to customers upon request,^[22] it went into effect the following year. In enacting these laws, California was not just concerned about entanglement issues as organisms come into contact with these macro-sized plastic particles; California also was cognizant that much of this plastic will break down over time to become microplastics.^[23]

Finally, California has taken action to regulate the production of microplastics themselves. In 2008, California enacted strict regulations^[24] on facilities that manufacture, handle and transport pre-production plastic pellets, which are particles a few millimeters in diameter that serve as the raw materials for plastic production; these particles can spill and become lost during transport. Subsequently, in 2015, California enacted a ban on the sale of personal care products that contain plastic microbeads.^[25] Comparable federal microbeads legislation was passed just months later; California's microplastics bead ban took effect in January 2020.

Developing a comprehensive microplastics management strategy

Even as California has implemented numerous regulatory mechanisms to slow the introduction and spread of microplastics in aquatic environments, the State also is laying a scientific foundation to assess the health risks associated with exposure. In 2018, the California State Legislature passed a pair of bills that require the State to begin building microplastics management strategies for both drinking water and California's coastal ocean and estuaries:

- Senate Bill 1422 requires the California State Water Resources Control Board to develop plans for measuring microplastic particles in drinking water by 2021.^[26]
- Senate Bill 1263 requires the California Ocean Protection Council to adopt and implement a

statewide strategy for lessening the ecological risks of microplastics to coastal marine ecosystems, especially through research and policy changes.^[27]

The State laws are notable for their prescriptiveness and specificity, even in environmentally progressive California. Both laws lay out priority actions, along with deadlines, and explicitly call on two State agencies to take responsibility for executing California’s microplastics management priorities. Embedded in each legislative mandate is the need for improved scientific understanding of how microplastics exposure affects both humans and marine organisms, and how much microplastics exposure, if any, is too much.

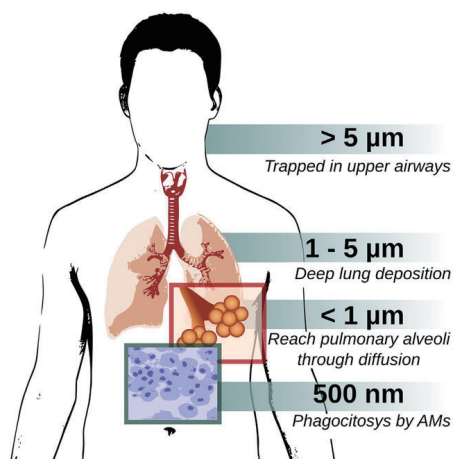

Figure 2 Like other airborne pollutants, microplastic particles can travel deep into the human body.^[28] Scientists are just beginning to document the health effects associated with continuous microplastics exposure. (Figure from Costa et al. 2016^[29], reprinted with permission)

As a direct result of the 2018 laws, California has been propelled to the forefront of microplastics research. The pair of laws has made it clear that California intends to immediately adopt, use, and incorporate microplastics science into action and policy. Thus, the 2018 legislation has become a call to action for the international scientific community: Develop clear, actionable recommendations that provide a scientific foundation for California’s microplastics management strategy. Meanwhile, scientists recognize that as California goes, so tends to go the rest of the nation. Microplastics measurement laboratories and water-quality managers across the U.S. may follow California’s lead - adopting California’s regulatory framework for managing microplastics in aquatic systems, and designing routine microplastics monitoring programs based on California’s.

Already, California is at the center of an international, year-long study to compare and evaluate various methods and instruments for measuring microplastics levels in water, sediment and tissue matrices. The study’s goal is to compare and standardize the many overlapping, experimental approaches that have been developed by microplastics researchers - and variations of these lab methods - to quantify and characterize microplastics levels. The study is being coordinated by the Southern California Coastal Water Research Project Authority on behalf of the State Water Resources Control Board and the California Ocean Protection Council.

More than 35 leading microplastics research labs worldwide have signed onto the study. Each participant will be sent blind samples containing known quantities of microplastics. They will use a variety of methods and instruments to quantify the microplastics in the samples, and

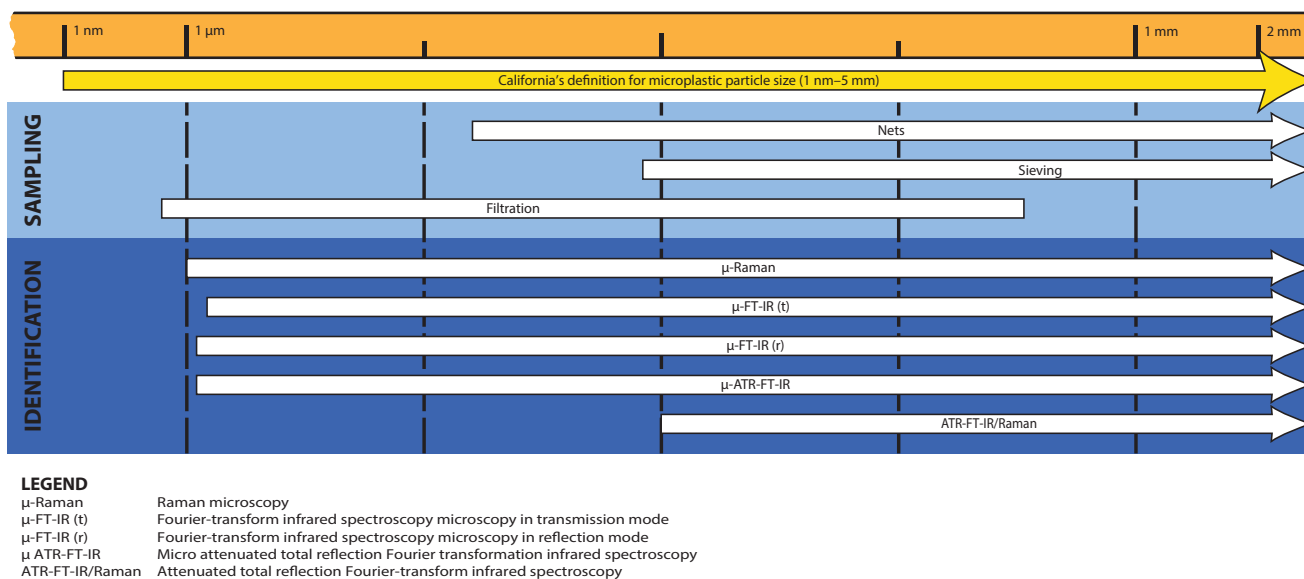

Figure 3 Various methods have been developed for sampling and identifying microplastic particles in the environment; they are designed to measure particles of different sizes.^[30-34] California’s adopted definition for microplastics encompasses all plastic particles that have at least three dimensions between 1 nm and 5 mm.

compare performance of the various methods and instrumentation; the end goal is to develop recommendations about which methods and which variations of methods produce the most reliable, repeatable, accurate results. HORIBA is among the study's partners, helping to lead training for study participants on the use of Raman spectroscopy, a leading candidate instrument for quantifying microplastic particles so small they can't be distinguished from non-plastics under a light microscope.

California's microplastics measurement methods study is expected to be immediately consequential, resulting in a dramatic consolidation of the nascent microplastics measurement field. The study also will provide clarity to state and federal agencies around the world about how to generate comparable, high-quality data. Finally, the standardized measurement methods are expected to be codified into laboratory accreditation standards. California's Environmental Laboratory Accreditation Program (ELAP), which is charged with overseeing the quality of all environmental data used for decision-making, will create a laboratory inspection process that includes development of performance evaluation samples. Laboratories that collect microplastics data for California will be required to participate in this process.

Ultimately, the foundational R&D work scoped out in the 2018 legislation will help California build capacity to monitor and ascertain the health risks from microplastics exposure. By making it possible for managers to reliably measure microplastics in water, sediment and tissue, and know that data are of high quality and comparable, California stands poised to develop a comprehensive, science-informed strategy for effectively managing microplastics in both drinking water and diverse aquatic ecosystems.

* This content is based on our investigation at the year of issue unless otherwise stated.

References

- [1] Hale, Robert C., Meredith E. Seeley, Mark J. La Guardia, Lei Mai, and Eddy Y. Zeng. "A Global Perspective on Microplastics." *Journal of Geophysical Research: Oceans* **125** (1). (2020). <https://doi.org/10.1029/2018JC014719>
- [2] Neufeld, Len, Fabienne Stassen, Ruth Sheppard, and Terry Gilman. "The New Plastics Economy: Rethinking the Future of Plastics." World Economic Forum. Geneva, Switzerland. (2016). http://www3.weforum.org/docs/WEF_The_New_Plastics_Economy.pdf
- [3] Lebreton, Laurent, and Anthony Andrady. "Future Scenarios of Global Plastic Waste Generation and Disposal." *Palgrave Communications* **5** (1): 6. (2019). <https://doi.org/10.1057/s41599-018-0212-7>
- [4] Lebreton, Laurent C. M., Joost van der Zwet, Jan-Willem Damsteeg, Boyan Slat, Anthony Andrady, and Julia Reisser. "River Plastic Emissions to the World's Oceans." *Nature Communications* **8** (1): 15611. (2017). <https://doi.org/10.1038/ncomms15611>
- [5] Murphy, Fionn, Ciaran Ewins, Frederic Carbonnier, and Brian Quinn. "Wastewater Treatment Works (WwTW) as a Source of Microplastics in the Aquatic Environment." *Environmental Science & Technology* **50** (11): 5800-5808. (2016). <https://doi.org/10.1021/acs.est.5b05416>
- [6] Ryan, Peter G. "Ingestion of Plastics by Marine Organisms." In *Hazardous Chemicals Associated with Plastics in the Marine Environment*, edited by Hideshige Takada and Hrisi K. Karapanagioti, 78:235-66. Cham: Springer International Publishing. (2016). https://doi.org/10.1007/698_2016_21
- [7] Akoueson, Fleurine, Lisa M. Sheldon, Evangelos Danopoulos, Steve Morris, Jessica Hotten, Emma Chapman, Jiana Li, and Jeanette M. Rotchell. "A Preliminary Analysis of Microplastics in Edible versus Non-Edible Tissues from Seafood Samples." *Environmental Pollution*, March, 114452. (2020). <https://doi.org/10.1016/j.envpol.2020.114452>
- [8] Coffin, Scott, Guo-Yong Huang, Ilkeun Lee, and Daniel Schlenk. "Fish and Seabird Gut Conditions Enhance Desorption of Estrogenic Chemicals from Commonly-Ingested Plastic Items." *Environmental Science & Technology* **53** (8): 4588-99. (2019). <https://doi.org/10.1021/acs.est.8b07140>
- [9] Roch, S., C. Friedrich, and A. Brinker. "Uptake Routes of Microplastics in Fishes: Practical and Theoretical Approaches to Test Existing Theories." *Scientific Reports* **10** (1): 3896. (2020). <https://doi.org/10.1038/s41598-020-60630-1>
- [10] Enders, Kristina, Robin Lenz, Colin A. Stedmon, and Torkel G. Nielsen. "Abundance, Size and Polymer Composition of Marine Microplastics ≥ 10 Mm in the Atlantic Ocean and Their Modelled Vertical Distribution." *Marine Pollution Bulletin* **100** (1): 70-81. (2015). <https://doi.org/10.1016/j.marpolbul.2015.09.027>
- [11] Song, Young Kyoung, Sang Hee Hong, Mi Jang, Gi Myung Han, Manviri Rani, Jongmyoung Lee, and Won Joon Shim. "A Comparison of Microscopic and Spectroscopic Identification Methods for Analysis of Microplastics in Environmental Samples." *Marine Pollution Bulletin* **93** (1): 202-9. (2015). <https://doi.org/10.1016/j.marpolbul.2015.01.015>
- [12] Kenyon, Karl W., and Eugene Kridler. "Laysan Albatrosses Swallow Indigestible Matter." *The Auk* **86** (2): 339-43. (1969). <https://doi.org/10.2307/4083505>
- [13] Hartmann, Nanna B., Thorsten Huffer, Richard C. Thompson, Martin Hassellöv, Anja Verschoor, Anders E. Daugaard, Sinja Rist, et al. "Are We Speaking the Same Language? Recommendations for a Definition and Categorization Framework for Plastic Debris." *Environmental Science & Technology* **53** (3): 1039-47. (2019). <https://doi.org/10.1021/acs.est.8b05297>
- [14] Rochman, Chelsea M., Cole Brookson, Jacqueline Bikker, Natasha Djuric, Arielle Earn, Kennedy Bucci, Samantha Athey, et al. "Rethinking Microplastics as a Diverse Contaminant Suite." *Environmental Toxicology and Chemistry* **38** (4): 703-11. (2019). <https://doi.org/10.1002/etc.4371>
- [15] https://www.waterboards.ca.gov/drinking_water/certlic/drinkingwater/microplastics.html
- [16] Coffin, Scott. 2020. "Staff Report for the Proposed Definition of Microplastics in Drinking Water (June 3, 2020)." Staff Report. Sacramento, CA: State Water Resources Control Board. https://www.waterboards.ca.gov/drinking_water/certlic/drinkingwater/docs/stffrprt_jun3.pdf
- [17] US Environmental Protection Agency. "National Primary Drinking Water Regulations; Final Rule. 40 CFR Parts 141, 142, and 143." *Federal Register*, 3526-97. (1991).
- [18] https://www.waterboards.ca.gov/water_issues/programs/trash_control/docs/01_final_sed.pdf
- [19] <http://ftp.secwpr.org/pub/download/DOCUMENTS/AnnualReports/2016AnnualReport/2016AnnualReport.pdf>
- [20] https://www.waterboards.ca.gov/water_issues/programs/trash_control/docs/01_final_sed.pdf
- [21] https://leginfo.ca.gov/faces/billNavClient.xhtml?bill_id=201320140SB270
- [22] https://leginfo.ca.gov/faces/billTextClient.xhtml?bill_id=201720180AB1884
- [23] <https://www.nationalgeographic.com/news/2018/05/plastics-explained/>
- [24] https://leginfo.ca.gov/faces/billNavClient.xhtml?bill_id=200720080AB258
- [25] https://leginfo.ca.gov/faces/billNavClient.xhtml?bill_id=201520160AB888
- [26] https://leginfo.ca.gov/faces/billTextClient.xhtml?bill_id=201720180SB1422
- [27] https://leginfo.ca.gov/faces/billNavClient.xhtml?bill_id=201520160SB1263
- [28] Lusher, Amy, Peter C. H. Hollman, and Jeremy Mendoza-Hill. *Microplastics in Fisheries and Aquaculture: Status of Knowledge on Their Occurrence and Implications for Aquatic Organisms and Food Safety*. FAO Fisheries and Aquaculture Technical Paper 615. Rome: Food and Agriculture Organization of the United Nations. (2017).
- [29] Costa, Ana, Marina Pinheiro, Joana Magalhães, Ricardo Ribeiro, Vitor Seabra, Salette Reis, and Bruno Sarmento. 2016. "The formulation of nanomedicines for treating tuberculosis." *Adv Drug Deliv Rev* **102**:102-115. <https://doi.org/10.1016/j.addr.2016.04.012>
- [30] Schwaferts, Christian, Reinhard Niessner, Martin Elsner, and Natalia P. Ivleva. "Methods for the Analysis of Submicrometer- and Nanoplastic Particles in the Environment." *TrAC Trends in Analytical Chemistry* **112** (March): 52-65. (2019). <https://doi.org/10.1016/j.trac.2018.12.014>
- [31] Primpke, Sebastian, Silke H. Christiansen, Win Cowger, Hannah De Frond, Ashok Deshpande, Marten Fischer, Erika Holland, et al. "EXPRESS: Critical Assessment of Analytical Methods for the Harmonized and Cost Efficient Analysis of Microplastics." *Applied Spectroscopy*, April, 000370282092146. (2020). <https://doi.org/10.1177/0003702820921465>
- [32] Cabernard, Livia, Lisa Roscher, Claudia Lorenz, Gunnar Gerds, and Sebastian Primpke. "Comparison of Raman and Fourier Transform Infrared Spectroscopy for the Quantification of Microplastics in the Aquatic Environment." *Environmental Science & Technology* **52** (22): 13279-88. (2018). <https://doi.org/10.1021/acs.est.8b03438>
- [33] https://www.agilent.com/cs/library/applications/5991-8271EN_microplastics_ftir_application.pdf
- [34] <https://assets.thermofisher.com/TFS-Assets/MSD/Application-Notes/WP53077-microplastics-identification-ftir-raman-guide.pdf>

Context Microscopy and Fingerprinting Spectroscopy of Micro- and Nanoplastics and Their Effects on Human Kidney Cells Using NanoGPS and Particle Finder



George SARAU, Ph.D.[§]

Fraunhofer Institute for Ceramic Technologies and Systems IKTS, Max Planck Institute for the Science of Light, Institute for Nanotechnology and Correlative Microscopy eV INAM



Melina YARBAKHT, Ph.D.[§]

Department of Nephrology, University Hospital, Friedrich-Alexander University Erlangen-Nürnberg (FAU), Translation Research Center



Barbara E. OßMANN, Ph.D.

Max Planck Institute for the Science of Light, Bavarian Health and Food Safety Authority



Lasse KLING

Max Planck Institute for the Science of Light, Institute for Nanotechnology and Correlative Microscopy eV INAM



Johannes AST, Ph.D.

Fraunhofer Institute for Ceramic Technologies and Systems IKTS, Institute for Nanotechnology and Correlative Microscopy eV INAM



Florian VOLLNHALS, Ph.D.

Institute for Nanotechnology and Correlative Microscopy eV INAM
Institute of Optics, Information and Photonics, Friedrich-Alexander University Erlangen-Nürnberg (FAU)



Janina MUELLER-DEILE, MD

Department of Nephrology, University Hospital, Friedrich-Alexander University Erlangen-Nürnberg (FAU), Translation Research Center



Mario SCHIFFER, MD, MBA

Department of Nephrology, University Hospital, Friedrich-Alexander University Erlangen-Nürnberg (FAU), Translation Research Center

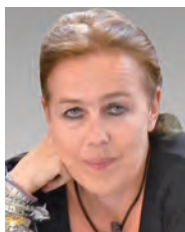

Silke H. CHRISTIANSEN, Ph.D.

Fraunhofer Institute for Ceramic Technologies and Systems IKTS, Max Planck Institute for the Science of Light, Institute for Nanotechnology and Correlative Microscopy eV INAM
Physics Department, Freie Universität Berlin

[§] These authors contributed equally to this work.

Nowadays humans are almost continuously exposed to micro- and nanoplastics (MNPs) through food and air, but very little is known about the exposure level and impact on our health. Here, we focus on bottled mineral water and cultured human podocytes as representative kidney cells prone to accumulation of particles. It is demonstrated that identical MNPs and cells can be precisely relocalized and extensively characterized down to nanoscale in independent instruments using nanoGPS and Particle Finder technologies developed by HORIBA. Reference particles and particles contained in mineral water were detected, enabling statistical distributions of their mean number, size, and type depending on the bottle and

label materials. The primary effects of MNPs (three standards and tyre wear) on human podocytes were assessed using a cell viability test followed by correlative microscopy and spectroscopy investigations of the same cells. We observed changes in the biological features of MNP treated cells compared to non-treated controls, attributed to cell damage through surface adhesion and uptake of plastic particles. The integration of automatic relocalization and detection of identical objects in a multi-instrument workflow represents a novel analytical approach that can be applied beyond this topic.

Key words

microplastic, nanoplastic, tyre wear, podocytes, kidney, nanoGPS, Particle Finder, SEM, Raman, correlative workflow, microscopy, spectroscopy

Introduction

Production of plastics has dramatically increased over the last decades and with it the plastic waste in the environment.^[1] Plastics are nowadays used almost in all products including packaging, construction, textiles, tires, cosmetics, and so on.^[2-4] The major issue is the mismanaged plastic waste that is not collected at all or improperly filtered and recycled, which significantly contaminates the environment on a global scale through the transfer between terrestrial, river, and ocean compartments.^[5] Once left in the environment, plastic debris persists and degrades continuously into smaller fragments down to micro- and nanoplastic (MNP) particles, attributed to size classes of < 5 mm and < 1 µm or ≤ 100 nm, respectively.^[6,7] With time, these MNPs are assumed to develop into toxic chemical cocktails by increased adsorption of hazardous pollutants and pathogens from the environment given their larger surface areas due to fragmentation, in addition to additives and pigments added during manufacturing of plastics. Moreover, the smaller the plastic particles become (< 1.5 µm), the higher the probability to enter by ingestion and inhalation into human organs and subsequently to accumulate and leach chemicals with still unknown toxicological effects on our health.^[8-10]

Microscopy- and spectroscopy-based methods are commonly used to monitor MNPs in environmental samples usually after filtering as well as in various biological matrices and organisms. The employed techniques mainly include optical microscopy with stereozoom, scanning electron microscopy (SEM) with energy dispersive X-ray spectroscopy (EDS), pyrolysis gas chromatography coupled with mass spectrometry (py-GC-MS), Fourier-transform infrared (FT-IR) and Raman microspectroscopies, each method with its benefits and drawbacks.^[11-13] Recently, we showed that a correlative approach is needed to avoid overestimation of particles' size and underestimation of particles' number for clustered MNPs as well as to measure Raman without optically visualizing the plastic nanoparticles by overlapping SEM and optical images of high (< 10 nm) and low (~ 1 µm) spatial resolution, respectively. This was achieved by

a correlative microscopy and spectroscopy workflow applied to identical MNP particles on large-area filters using an optical zoom microscope and a hyphenated SEM-Raman instrument (with a bright field optical objective for micro-Raman inside the SEM vacuum chamber).^[14] However, such combined systems are limited with respect to the number of measurement techniques available on one instrument compared to stand-alone, method-specific instruments from different manufacturers, in which finding the same micro- and nanosized objects is still a challenge.^[15-19]

In this work, the first application of a newly developed relocalization technology for a detailed characterization of MNPs and their effects on human kidney cells in independent instruments is demonstrated. This technology is based on a patented position encoder tag (from HORIBA), called nanoGPS tag, with lithographically defined patterns. These patterns are used to translate the sample coordinates corresponding to the regions of interest (ROIs) into the stage coordinates of different instruments (from HORIBA, Zeiss, Leica in this study), regardless of the sample orientation. Furthermore, the applicability of the Particle Finder software module (from HORIBA) for automatic detection of microplastic (MP), pigment, and additive particles on large-area filters is shown. Context microscopy and fingerprinting spectroscopy approaches were applied to standard MPs, microparticle contamination of bottled mineral water, and human podocytes that were either untreated or incubated with MNPs. The podocytes exposed to MNPs were under stress and started to die gradually, indicating an overall effect of particle exposure on cell viability.

Experimental

The samples investigated in this study can be divided into three categories: reference micro-sized plastic particles, mineral water from different bottle types bought in Bavarian food stores, and human podocytes cell cultures exposed to MNPs.

Standard MP particles

Commercially available standard plastics (see Table 1) were selected to match the polymer types routinely encountered in the environment.^[13,20,21] A mixture of polyethylene (PE), poly(vinyl chloride) (PVC), polyamide-Nylon 6 (PA), polystyrene (PS), and polypropylene (PP) particles were suspended in a solution (ultrapure water and sodium dodecyl sulphate (SDS)) followed by vacuum filtration through polycarbonate (PC) membrane filters (diameter 25 mm, pore size 0.4 μm) previously coated with aluminum (Al thickness 100 nm) as detailed in our previous work.^[22] These reference materials were used to evaluate the nanoGPS relocalization technology (hardware

and software) and its integration in a correlative microscopy and spectroscopy workflow applied to identical MNP particles (see Figure 1). The nanoGPS tag (4×5 mm² silicon piece) is firmly attached next to the filter, which is rigidly stretched and flattened between two metal rings fixed on a SEM holder, to avoid any thermal drift and ensure precise relocalization in different instruments. Along with the corresponding NaviGo software, the instruments' stages involved in the workflow are calibrated and the coordinates of ROIs are recorded.

Mineral water particles

Real mineral water samples packaged in reusable bottles

Table 1 Details of the plastic particle standards used in the present study to assess the nanoGPS relocalization and the exposure of human podocytes to plastics (PVC, PA, PP). Adapted with permission from Springer Nature.^[22]

Material	Type	Manufacturer	Size (μm)
Polyethylene (PE)	Clear microspheres, powder	Cospheric	1-10
			10-106
Poly (vinyl chloride) (PVC)	Powder	Pyropowders.de	< 50
Polyamide - Nylon 6 (PA)	Powder	GoodFellow	15-20 (average particle size)
Polystyrene (PS)	Polybead Micron Microspheres, 2.5% solids in water	Polysciences Inc.	1
Polypropylene (PP)	Chromatographic Grade, powder	Polysciences Inc.	25-85

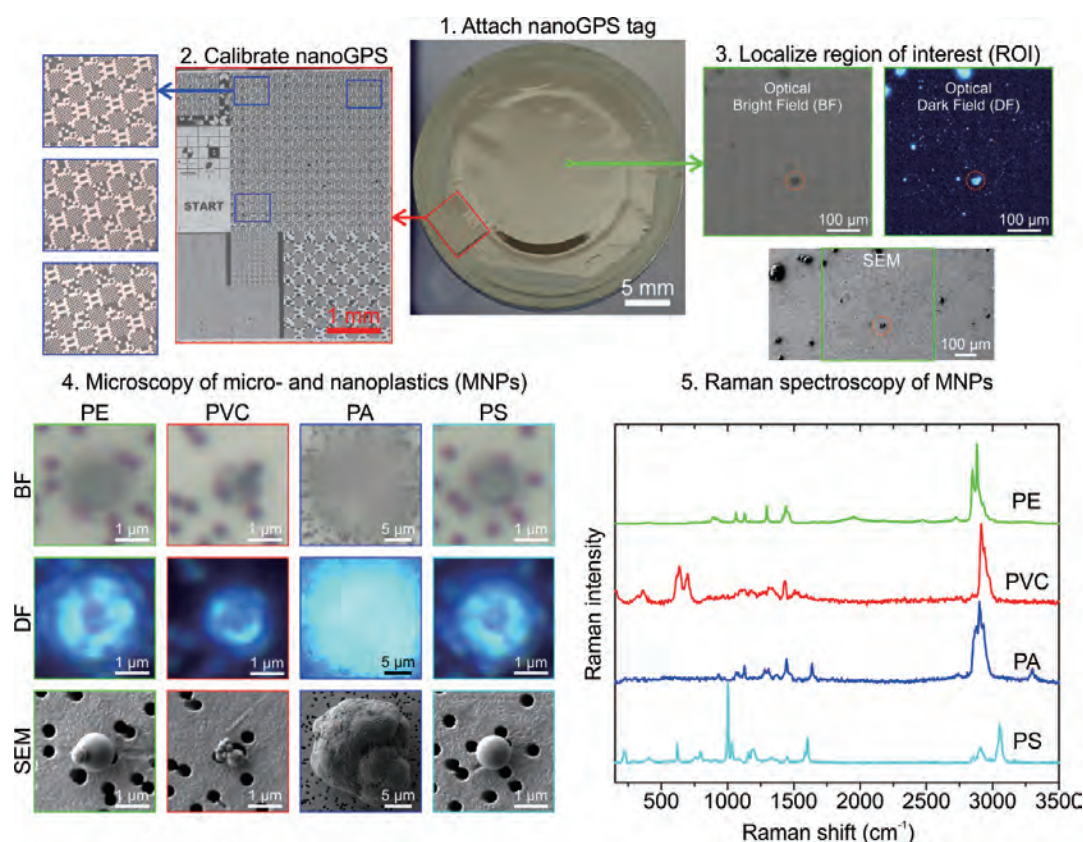

Figure 1 Correlative microscopy and spectroscopy workflow for micro- and nanoplastics on an Al coated PC membrane used to filter MNPs from water. First, a so-called nanoGPS tag is attached directly to the sample. Second, three images are recorded at random positions on a pattern (different patterns correspond to various instrument magnifications) and fed into a software that calibrates the global, stage coordinates into local, tag (sample) coordinates including sample rotation. This procedure is repeated for each instrument to be used in the workflow. Third, identical ROIs are precisely relocalized in independent instruments, regardless of the sample orientation. Fourth, the same single or agglomerated particles are imaged at optical (BF, DF) and SEM spatial resolutions to assess size, shape, number, and surface morphology of MNPs down to nanoscale. DF imaging is used to clearly distinguish MNPs from the porous structure of large-area filters. Fifth, unambiguously chemical identification by micro-Raman spectroscopy is applied. The Raman spectra are taken with permission from the Society for Applied Spectroscopy.^[14]

made of poly(ethylene terephthalate) (PET), in single use PET bottles, and in glass bottles (single and reusable) were analyzed for microparticle contamination, taking also into account bottle age as well as label and cap type. Before suspension in SDS solution and vacuum filtration through Al coated PC membranes, calcium and magnesium carbonate particles were dissolved with ethylene diamine tetraacetic acid tetrasodium salt (EDTA) to reduce the number of non-plastic particles.^[21] To obtain statistically relevant data given the complexity of bottled mineral water contamination including microplastic, pig-

ment, additive, and mixed particles, we employed an automatic particle detection approach. This is based on the Particle Finder software that transforms large-area (1 mm²) dark field optical images obtained by stitching into grey scale images, on which particles are easily detectable using their brightness, counted, classified by size and shape, and their coordinates recorded for further micro-Raman chemical identification. Thus, the mean number of microplastic, pigmented, and additive particles (projected to 1 L sample volume), their size, and type distributions were estimated (see Figure 2, additives not

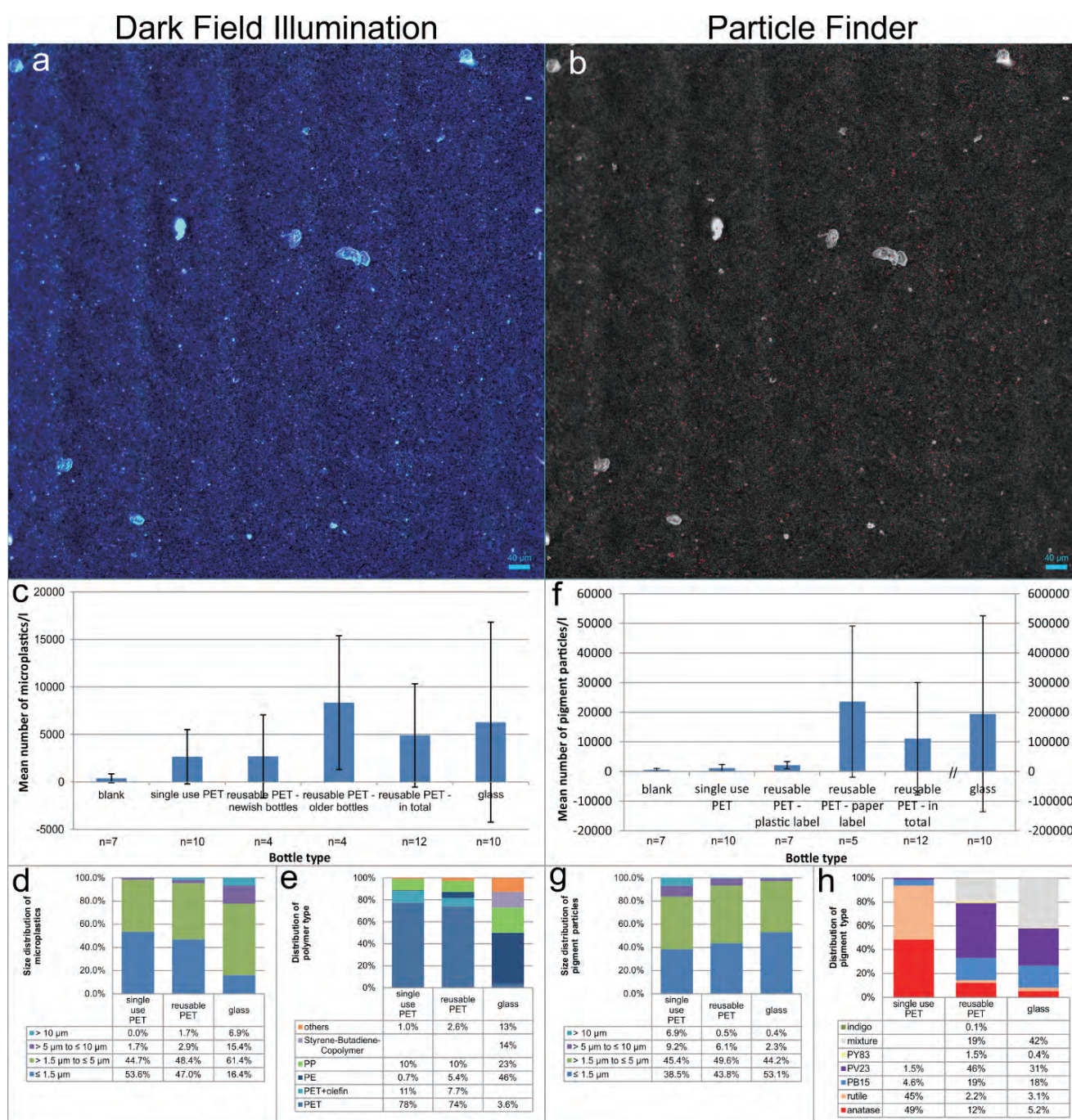

Figure 2 (a) Example of a dark field montage (1 mm²) obtained by stitching, on which particles from mineral water samples shine brighter than the pores of the Al coated PC membrane filter. (b) Particle Finder software converts the DF image into a grey scale image used to automatically detect, classify, and measure Raman spectra of individual particles at their center, marked by red points. (c, d, e) Mean number of microplastics ± standard deviation projected to 1 L sample volume, size, and plastic type distributions function of the bottle material. (f, g, h) Mean number of pigments ± standard deviation projected to 1 L sample volume, size, and pigment type distributions function of the bottle material. Adapted with permission from Elsevier.^[21]

included).^[21,22]

Human podocytes exposure to MNPs

Conditionally immortalized human podocytes that contain a heat sensitive CV40T antigen were cultured as described previously.^[23] Podocytes were proliferated under growth permissive conditions at 33°C and further differentiated through the inactivation of SV40 T-antigen at 37°C. After 7 days of differentiation, cells were treated with different concentrations of diluted standard plastic (PVC: 0.5, 1 mg/ml; PA: 0.5, 1 mg/ml; PP: 2.5, 5 mg/ml) and tyre wear (0.125, 0.5 mg/ml) particles for 7 h to evaluate their possible effects on the cells. In order to decrease the aggregation of particles, they were sonicated before the incubation. Following the particle treatment, cells were washed two to three times with phosphate buffered saline (PBS) and fixed for further biological, imaging, and spectroscopy assays. For this study, the podocytes were grown on the surface of silicon wafers previously coated with platinum (Pt thickness 100 nm) that were attached along with nanoGPS tags to SEM holders to avoid relative sample - tag position shifts when moving between instruments.

Analytical methods

Complementary analytical techniques present on different

instruments were used to visualize and detect MNPs on filters and inside cells as well as to determine the changes in cells caused by the contact with MNPs. All measurements have been performed at room temperature. The latter point was first addressed by using a live-dead cell imaging kit based on two-color fluorescence cell viability assay (Thermo Fischer Scientific). Based on this assay, cell-permeable and cell-impermeable dyes were used for staining of live and dead/dying cells, respectively. Following the particle treatment, the live/dead cells were assigned based on the kit instruction. Fluorescent images were collected with the use of an Evos M5000 imaging microscope (Thermo Fischer Scientific) (see Figure 3).

Furthermore, we employed a confocal micro-Raman spectrometer (HORIBA LabRAM HR Evo-Nano or XploRa PLUS), operated by the LabSpec 6 software (with data analysis and Particle Finder), equipped with bright and dark field illumination (BF, DF) objectives coupled to a camera to image MNPs and cells (~ 1 µm spatial resolution). Three lasers (532, 633, and 785 nm) focused by 50× (NA 0.75) or 100× (NA 0.9) objectives were used for Raman excitation and collection in a backscattering geometry with laser powers of 1.2 mW or 3.2 mW (532 nm), 11.2 mW (633 nm), and 5.3 mW (785 nm). Two gratings (300 and 600 grooves/mm) and integration times of 1

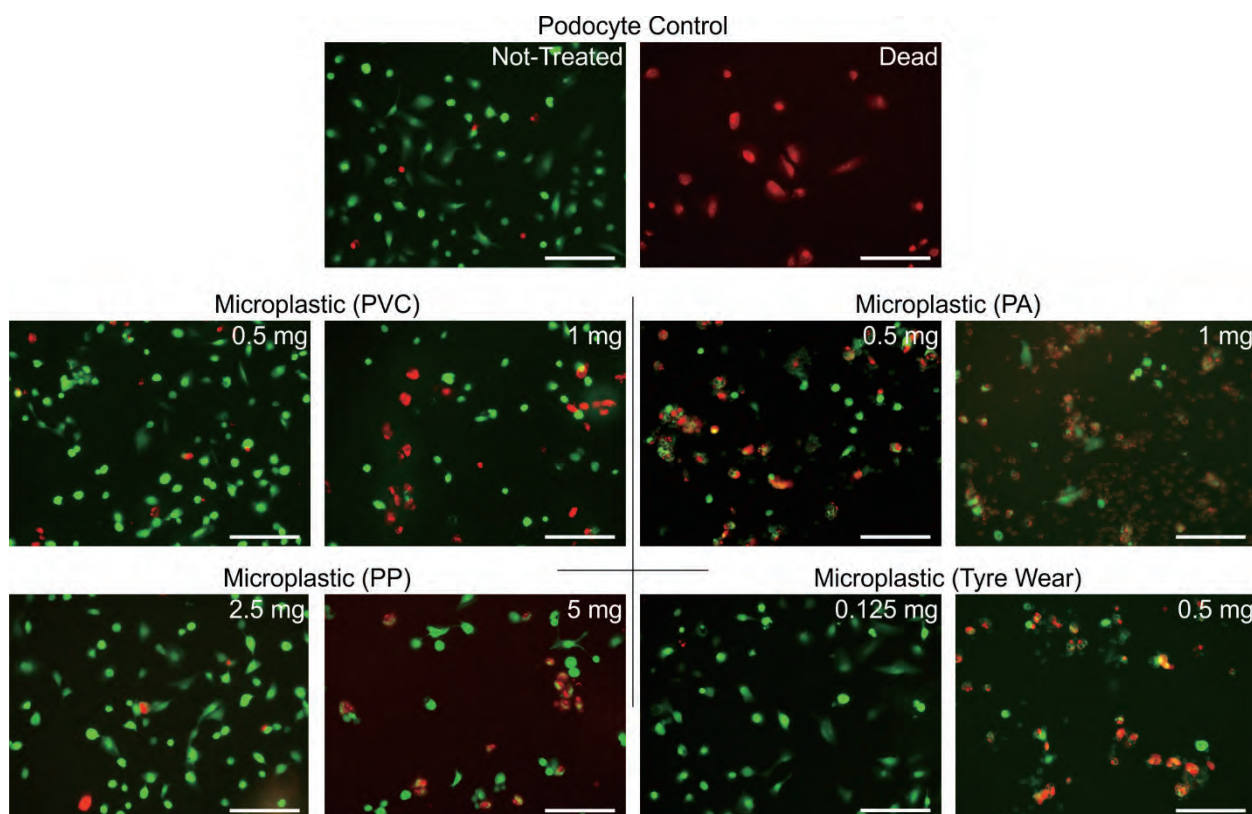

Figure 3 Fluorescence live - dead cell imaging (green - red) to assay the cytotoxicity of microplastic and tyre wear particles on podocytes, following 7 h particle exposure at relevant concentrations (mg/ml) and washing with PBS. The control cells were non-treated or intentionally killed to check the live - dead cell imaging kit. The concentrations to initiate and induce a notable impact on podocytes depends on the polymer type. During particle incubation the cells are under stress and start to die gradually. Consequently, some of the degraded cells are washed away and not assigned with colors. Some attached particles with intrinsic fluorescence are also visible. The preliminary results of this assay are yet mostly qualitative and show an overall effect of particle treatment on the cell viability. Scale bars are 300 µm.

- 20 s and 2x accumulations were applied. The acquired Raman spectra and maps (step size 1 μm) were analyzed to chemically identify the particles and the structural damage induced by them on the human podocytes. A SEM (Zeiss field emission Auriga, secondary electron detector) was used for a detailed morphological imaging of MNPs and cells (< 10 nm spatial resolution) at a low voltage of 1 kV to avoid modifications caused by electron scanning. The height profiles of the same cells investigated by micro-Raman and SEM were measured by a confocal imaging microscope (Leica DCM 3D), the relocalization of identical cells being realized using the nanoGPS technology (see Figure 4). Moreover, because of the superposition of Raman bands related to the plastic materials and cells, we applied a classical least squares algorithm (CLS) available in LabSpec 6 to highlight the spatial distribution of MNPs on the mapped cells (see Figure 5).

Results and Discussion

NanoGPS relocalization

The nanoGPS relocalization technology for correlative microscopy and spectroscopy investigations is illustrated in Figure 1 for standard micro-sized plastic particles (Table 1), with some particles being by chance < 1 μm . First, a nanoGPS tag is rigidly mounted next to the Al coated PC membrane filter, both on a SEM holder that is moved between instruments, such that the tag and sample keep their positions relative to each other. The smaller the distance between tag and sample, the better the relocaliza-

tion accuracy that can be further influenced by stage and imaging characteristics. Second, the multiscale and multimodal patterns on the tag are employed to calibrate the stage of each instrument, different feature sizes being used for distinct instrument magnifications (see SEM image of the entire tag). Three images are taken at random positions on a chosen pattern and fed along with the global, stage coordinates into the NaviGo software. In this example, images were recorded with the 10 \times objective of the optical microscope on the micro-Raman spectrometer. The software automatically determines the local, sample coordinates and rotation with respect to the tag. This calibration procedure is repeated for all instruments in the workflow and can be recalled anytime by recording one single image on the same pattern, independent of stage and sample rotation.

In the third step, one or more ROIs are located on the filter and their sample coordinates are saved in one instrument and retrieved in other instruments by converting sample, local into stage, global coordinates. In our case, large-area optical images acquired by stitching under BF and DF illumination are compared to a large field of view SEM image, with the same particle marked on all overview pictures. Next, MNPs can be directly relocalized and imaged at spatial resolutions of optical and electron microscopies (step four) and their spectral fingerprints determined by micro-Raman spectroscopy (step five) (PP is not shown). While on the BF and DF optical images these particles appear to be single, SEM imaging reveals that PE and PVC are cluster particles. When approaching

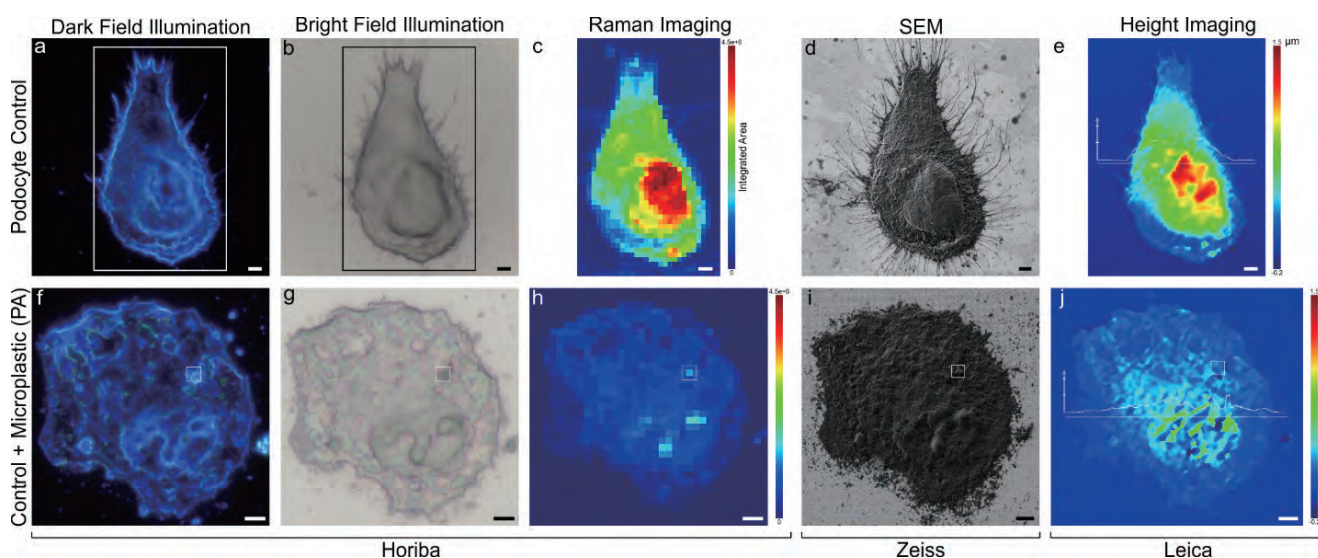

Figure 4 Correlative microscopy and spectroscopy workflow applied to podocytes untreated, control (first row) and particle treated (second row) with 1 mg/ml PA (Table 1 and Figure 3) using the nanoGPS position encoder tag (Figure 1). Two representative cells were easily relocalized and investigated in three independent instruments from different manufactures (Horiba, Zeiss, Leica) with complementary analytical techniques. First, an integrated optical microscope with dark (a, f) and bright (b, g) field illumination and micro-Raman spectrometer are used for a fast visual inspection of cells, followed by Raman imaging (c, h), showing less Raman signal for treated cells (note the same scale) that is an indication of podocytes damage after exposure to PA. Second, SEM imaging (d, i) reveals detailed surface morphology changes at nanoscale induced by the PA treatment and visualizes a PA nanoparticle (~ 30 nm), as confirmed by micro-Raman spectroscopy, delimited by the square in the second row. Third, an interferometric profilometer is employed to measure the height profile without (e) and with (j) plastic contamination (note the same scale), PA incubated cells being flatter. Two horizontal profiles are also shown (maximum heights of ~ 1.5 μm and ~ 0.8 μm for the control and treated cell, respectively). Scale bars are 3 μm .

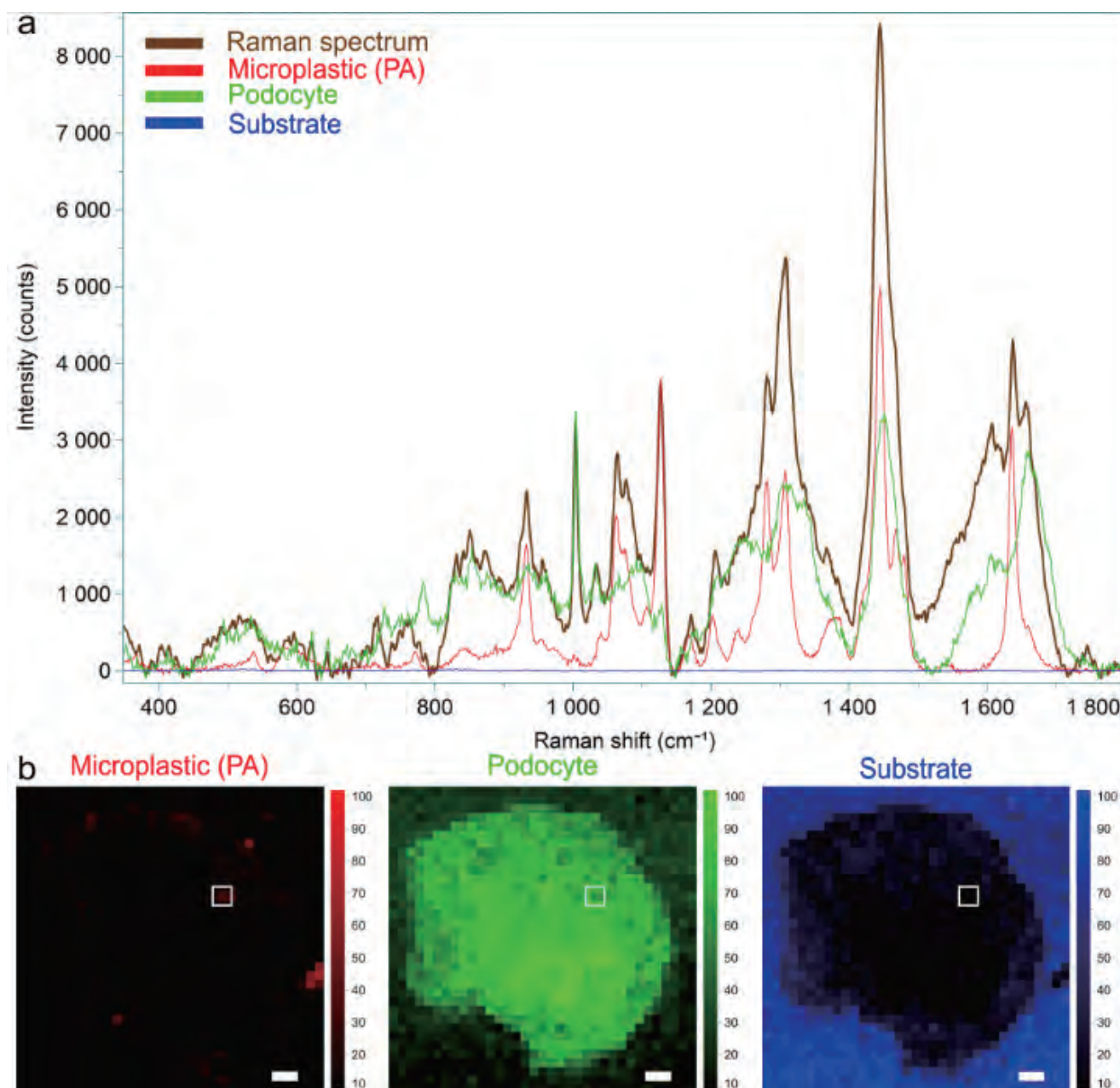

Figure 5 (a) Classical least squares (CLS) fitting is applied to decompose each measured Raman spectrum into its spectral components based on given reference spectra. (b) Separate score maps are generated for each component as illustrated for the podocyte cell treated with PA shown in Figure 4 (second row). The square indicates the position of a PA particle. Thus, despite the superimposed and complex Raman bands of cells and MNP particles, the spatial distribution of MNPs can be clearly localized. Scale bars are 3 μm .

the filter pore size, particles are barely visible in BF, but clearly noticeable in DF because they shine brighter than the pores, as seen for PVC. Moreover, SEM shows smooth surfaces with spherical and fragment-like shapes for the studied polymer particles. It should be noted that BF, DF, and Raman are usually performed before SEM; however, low-voltage SEM does not damage MNPs, so that Raman after SEM is also possible.^[14] All in all, nanoGPS tagging enables sample navigation and observation at different length scales in independent instruments, thus detailed morphological (size, shape, surface, number) and chemical characterization of the same micro- and nanoparticles is achievable.

Particle Finder

The Particle Finder software module combined with DF optical microscopy and micro-Raman spectroscopy represents another example of correlative analysis applied here to study contamination by microplastic, pigment, and additive particles in bottled mineral water. 32 samples from 21 different brands of mineral water were investigated to determine the number, size, and type of particles, the results being summarized in Figure 2.^[21] DF imaging is used to scan five large-area image montages (1 mm²) on each sample to warrant significant particle statistics. Such a montage generated by stitching (Figure 2a) is then converted into a grey scale image, on which all particles $\geq 1 \mu\text{m}$ are automatically detected and individually

measured by micro-Raman (Figure 2b).

We identified varying amounts of microplastics in water from all bottle types, partly resulting in large error bars when calculating the mean particle number (Figure 2c); however, some trends are clearly visible. On average, higher number of microplastics were found in water from reusable (PET and glass) compared to single use PET bottles. Interestingly, newish, reusable PET showed less microplastics than older, reusable PET, but similar to single use PET, suggesting that the bottle age can critically affect MP contamination. Regarding the average size distribution, 90.5% of MPs were $\leq 5 \mu\text{m}$ in all bottles and $\sim 50\%$ were $\leq 1.5 \mu\text{m}$ in PET bottles (Figure 2d), these MP size classes being addressed for the first time in such samples.^[21,24] The predominant polymer type detected in PET bottles was PET considered to originate from the bottle material, while some PET particles displayed olefinic or pigment spectral interferences. In glass bottles, we mainly found PE and PS attributed to abrasion of caps on the glass bottleneck as well as PS, styrene-butadiene-copolymer, and PET most likely from the machinery used for the cleaning process (Figure 2e).

In addition to microplastics, pigmented and additive particles were also detected in the analyzed mineral water samples. Large variations in the number of pigmented particles in water from different bottle and label types were observed (Figure 2f). On average, single use PET contained less pigments similar to blank samples, while reusable PET and glass bottles with printed paper labels showed higher amounts of pigments. Alike MPs, older, reusable PET displayed more pigments than newish, reusable PET and most of the pigmented particles belonged to size classes investigated for the first time, 91.5% were $\leq 5 \mu\text{m}$ and 45.1% were $\leq 1.5 \mu\text{m}$ (Figure 2g).^[21,24] We found that the pigment types mainly correspond to the colors used for printing on the paper labels (Figure 2h). These pigment particles originate from the paper labels and enter into the bottles during the cleaning process.^[25] Additive particles were detected in reusable PET bottles and considered to leach from the bottle material (68.6% were $\leq 5 \mu\text{m}$ and 11.7% were $\leq 1.5 \mu\text{m}$). These results demonstrate that Particle Finder can be used for automatic detection, classification, and Raman measurement of particles $< 1.5 \mu\text{m}$ from real samples, which is very important due to toxicological reasons, since this size class is considered small enough to penetrate deeply into organs.^[21,22]

Effects of MNPs on podocytes

The potential risk of plastic particles on human health is addressed in this study using human podocytes as a highly-specialized kidney cell type. Since kidneys are involved in the filtration process and do not regenerate

their cells continuously, they are likely to accumulate MNPs over the lifetime.^[26] We performed cell viability tests after incubation of podocytes with four different MNP types (standards PVC, PA, PP, and tyre wear) using a live-dead (green - red) cell fluorescent based kit. Representative results for relevant plastic concentrations after 7 h exposure with respect to control cells are summarized in Figure 3. The cytotoxicity response is found to depend on the polymer type, a higher concentration is needed for PP (5 mg/ml) compared to PVC, PA, and tyre wear (0.5 - 1 mg/ml) to achieve a similar cell mortality rate. Two mechanisms are proposed to explain the damage induced by the plastic particles on podocytes and finally their death. First, particles can attach on the cell surface and limit the nutrient uptake, the degree of attachment depending on particles' adhesion properties and sizes. Some particles still remained attached after three times washing with PBS following incubation and can be visualized based on their intrinsic fluorescence as shown in Figure 3. Second, smaller size particles can be taken up into the cells by phagocytosis as illustrated in Figure 4 for PA particles.

The correlative microscopy and spectroscopy characterization of identical cells using the nanoGPS relocalization technology is demonstrated in Figure 4, exemplary shown for PA treated cells. Two representative podocytes (control and incubated) are localized in three independent instruments and studied with complementary analytical techniques down to nanoscale resolution. Optical imaging ($\sim 1 \mu\text{m}$ spatial resolution) under DF (a, f) and BF (b, g) illumination show the degradation and deformation of cells after particle exposure. The structural damage is further confirmed by micro-Raman mapping (c, h), treated cells display Raman spectra with less intensity (note the same scale for the integrated area maps). High spatial resolution SEM imaging ($< 10 \text{ nm}$) is used to assay the integrity of cell features at nanoscale, exposed cells do not regularly show normal biological features like heterogeneous surface, nucleus, and foot processes (d, i). Height profile imaging acquired with an interferometric profilometer quantifies the deformation of incubated cells that flatten with respect to control cells (e, j), with height changes from $\sim 0.8 \mu\text{m}$ to $\sim 1.5 \mu\text{m}$, respectively (note the same scale). Given the complex peak structure of Raman spectra from cells and plastic particles and the large overlap between peaks, we employed a CLS fitting algorithm that decomposes each measured Raman spectrum into its spectral components and provides score distribution maps for each component as displayed in Figure 5. This enables us to spatially resolved MNPs without underlying podocyte and substrate backgrounds, which are shown separately. Taking advantage of the nanoGPS relocaliza-

tion capability in a correlative workflow, the same PA particle (outlined by the square in Figure 5b and Figure 4 - second row) was imaged by SEM and found to be a nanoparticle (~ 30 nm) most likely taken up into the cell by phagocytosis (Figure 4i). All in all, these preliminary experiments indicate the negative influence of plastic particles on human podocyte cells; however, more assays are needed to account for other relevant polymers present in the environment and their separate and mixed effects on different human organs, tissues, and cells.

Conclusion

The present study introduces an efficient measurement protocol for the assessment of contamination, accumulation, and hazards related to micro- and nanoplastic particles in bottled mineral water and human kidney cells. This protocol combines context microscopy and fingerprinting spectroscopy with automated relocalization (nanoGPS) and detection (Particle Finder) of the same MNPs and cells in separate instruments from distinct manufactures (HORIBA, Zeiss, Leica). Results on microparticle contamination (average number, size, type) in mineral water and toxicity effects of MNPs (standards PVC, PA, PP, and tyre wear) on podocytes (in-vitro) are reported. It was found that the bottle material (single use, reusable PET and glass), bottle age (older, newish reusable PET), and label print (paper, plastic) affect the distributions of microplastics, pigments, and additives. In contrast to non-treated controls, podocytes incubated with MNPs tend to lack usual cell characteristics such as heterogeneous surface, nucleus, and foot processes, confirming the potential risk of plastic particles on the viability of cells. These findings were revealed by a biological cell test supported by complementary methods involving optical (bright, dark field) and scanning electron microscopy, micro-Raman spectroscopy (with CLS spectra fitting), and height interferometric profilometry. Further work will deal with different plastic types, concentrations, and exposure times.

Acknowledgements

GS, JA, FV, LK, and SHC acknowledge the financial support from the European Union within the research projects npSCOPE and 4D+nanoSCOPE. BEO thanks the Bavarian State Ministry of the Environment and Consumer Protection for funding the projects 'Detection of microplastics in selected foods' and 'Expansion of the analytics of microplastics in food'. The authors thank Adam Boies from University of Cambridge for providing the tyre wear particles.

* This content is based on our investigation at the year of issue unless otherwise stated.

George Sarau and Melina Yarbakht contributed equally to this work.

References

- [1] L. Lebreton, A. Andrady. "Future scenarios of global plastic waste generation and disposal". *Palgrave Commun.* 2019. **5**(1): 6.
- [2] R. Geyer, J.R. Jambeck, K.L. Law. "Production, use, and fate of all plastics ever made". *Sci. Adv.* 2017. **3**(7): e1700782.
- [3] P.J. Kole, A.J. Löhr, F. Van Belleghem, A. Ragas. "Wear and Tear of Tyres: A Stealthy Source of Microplastics in the Environment". *Int. J. Environ. Res. Public Health.* 2017. **14**(10): 1265.
- [4] L.M. Hernandez, N. Yousefi, N. Tufenkji. "Are There Nanoplastics in Your Personal Care Products?" *Environ. Sci. Technol. Lett.* 2017. **4**(7): 280-285.
- [5] C.M. Rochman. "Microplastics research—from sink to source". *Science.* 2018. **360**(6384): 28-29.
- [6] K. Munno, H. De Frond, B. O'Donnell, C.M. Rochman. "Increasing the Accessibility for Characterizing Microplastics: Introducing New Application-Based and Spectral Libraries of Plastic Particles (SLoPP and SLoPP-E)". *Anal. Chem.* 2020. **92**(3): 2443-2451.
- [7] L.M. Hernandez, E.G. Xu, H.C.E. Larsson, R. Tahara, V.B. Maisuria, N. Tufenkji. "Plastic Teabags Release Billions of Microparticles and Nanoparticles into Tea". *Environ. Sci. Technol.* 2019. **53**(21): 12300-12310.
- [8] S.L. Wright, F.J. Kelly. "Plastic and Human Health: A Micro Issue?" *Environ. Sci. Technol.* 2017. **51**(12): 6634-6647.
- [9] R. Lehner, C. Weder, A. Petri-Fink, B. Rothen-Rutishauser. "Emergence of Nanoplastic in the Environment and Possible Impact on Human Health". *Environ. Sci. Technol.* 2019. **53**(4): 1748-1765.
- [10] J.C. Prata, J.P. da Costa, I. Lopes, A.C. Duarte, T. Rocha-Santos. "Environmental exposure to microplastics: An overview on possible human health effects". *Sci. Total Environ.* 2020. **702**: 134455.
- [11] W.J. Shim, S.H. Hong, S.E. Eo. "Identification methods in microplastic analysis: a review". *Anal. Methods.* 2017. **9**(9): 1384-1391.
- [12] G. Renner, T.C. Schmidt, J. Schram. "Analytical methodologies for monitoring micro(nano)plastics: Which are fit for purpose?" *Curr. Opin. Environ. Sci. Heal.* 2018. **1**: 55-61.
- [13] L. Cabernard, L. Roscher, C. Lorenz, G. Gerdt, S. Primpke. "Comparison of Raman and Fourier Transform Infrared Spectroscopy for the Quantification of Microplastics in the Aquatic Environment". *Environ. Sci. Technol.* 2018. **52**(22): 13279-13288.
- [14] G. Sarau, L. Kling, B. Ossmann, A.-K. Unger, F. Vogler, S.H. Christiansen. "Correlative Microscopy and Spectroscopy Workflow for Microplastics". *Appl. Spectrosc.* 2020. 000370282091625.
- [15] C. Cardell, I. Guerra. "An overview of emerging hyphenated SEM-EDX and Raman spectroscopy systems: Applications in life, environmental and materials sciences". *TrAC Trends Anal. Chem.* 2016. **77**: 156-166.
- [16] G. Sarau, M. Heilmann, M. Latzel, C. Tessarek, S. Christiansen. "GaN-Based Nanorods/Graphene Heterostructures for Optoelectronic Applications". *Phys. Status Solidi B.* 2019. **256**(4): 1800454.
- [17] G. Sarau, M. Heilmann, M. Latzel, S. Christiansen. "Disentangling the effects of nanoscale structural variations on the light emission wavelength of single nano-emitters: InGaN/GaN multiquantum well nano-LEDs for a case study". *Nanoscale.* 2014. **6**(20): 11953-11962.
- [18] G. Sarau, M. Heilmann, M. Bashouti, M. Latzel, C. Tessarek, S. Christiansen. "Efficient Nitrogen Doping of Single-Layer Graphene Accompanied by Negligible Defect Generation for Integration into Hybrid Semiconductor Heterostructures". *ACS Appl. Mater. Interfaces.* 2017. **9**(11): 10003-10011.
- [19] G. Sarau, S. Christiansen, M. Holla, W. Seifert. "Correlating internal stresses, electrical activity and defect structure on the micrometer scale in EFG silicon ribbons". *Sol. Energy Mater. Sol. Cells.* 2011. **95**(8): 2264-2271.
- [20] S.-A. Strungaru, R. Jijie, M. Nicoara, G. Plavan, C. Faggio. "Micro(nano) plastics in freshwater ecosystems: Abundance, toxicological impact and quantification methodology". *TrAC Trends Anal. Chem.* 2019. **110**: 116-128.
- [21] B.E. Oßmann, G. Sarau, H. Holtmannspötter, M. Pischetsrieder, S.H. Christiansen, W. Dicke. "Small-sized microplastics and pigmented particles in bottled mineral water". *Water Res.* 2018. **141**: 307-316.
- [22] B.E. Oßmann, G. Sarau, S.W. Schmitt, H. Holtmannspötter, S.H. Christiansen, W. Dicke. "Development of an optimal filter substrate for the identification of small microplastic particles in food by micro-Raman spectroscopy". *Anal. Bioanal. Chem.* 2017. **409**(16): 4099-4109.
- [23] J. Müller-Deile, K. Worthmann, M. Saleem, I. Tossidou, H. Haller, M. Schiffer. "The balance of autocrine VEGF-A and VEGF-C determines podocyte survival". *Am. J. Physiol. Physiol.* 2009. **297**(6): F1656-F1667.
- [24] D. Schymanski, C. Goldbeck, H.-U. Humpf, P. Fürst. "Analysis of microplastics in water by micro-Raman spectroscopy: Release of plastic particles from different packaging into mineral water". *Water Res.* 2018. **129**: 154-162.
- [25] B.E. Oßmann. "Determination of microparticles, in particular microplastics in beverages". 2020. urn:nbn:de:bvb:29-opus4-132788.
- [26] X. Xu, G. Wang, N. Chen, T. Lu, S. Nie, G. Xu, et al. "Long-term exposure to air pollution and increased risk of membranous nephropathy in China". *J. Am. Soc. Nephrol.* 2016. **27**(12): 3739-3746.

Microplastic Analysis in Seawater - Minimum Requirements for Comparative Data Generation

Amy LUSHER, Ph.D.

Norwegian Institute for Water Research



Scientific, regulatory and societal interests in environmental pollution by microplastics has led to the requirement for quality assured and harmonized approaches to assessing samples for microplastics. Many methods for seawater sampling have emerged with varying degrees of comparability. For example, one of the most widely applied field methods - surface net sampling - is limited in comparative data generation for particles $< 300 \mu\text{m}$. Other developments using different sampling pumps and automated approaches require method validation and harmonization. Furthermore, there are several different analytical approaches with varying detection limits, costs and technical readiness levels for implementation. This lack of inter-comparison complicates a global understanding of microplastics levels in the marine environment. Encouragingly, methods are continuously being improved to further automatize sampling, sample pretreatment and final analysis with a far greater attention to validation. The minimum requirements for comparative data generation in seawater must include careful consideration of sampling parameters, analytical processes and data treatment all conducted with a high level of QA/QC.

Introduction

Microplastics, or at least particles now considered as microplastics ($< 5 \text{ mm}$, GESAMP 2019), were first identified in surface seawater samples dating back to the 1960's during plankton surveys.^[1] Investigations which followed generally used similar techniques with nets to sweep surface waters and quantify particles visually^[2] and later using a suit of analytical techniques to confirm the presence of plastic polymers, including infrared and Raman spectroscopy and thermal desorption or degradation coupled to mass spectrometry.^[3] Surface net sampling has proven valuable in the establishment of long-term data sets.^[4-5] Unfortunately, this method is hampered in adverse weather conditions and other limitations related to the determination of accurate sample volumes, lower size limit of particles (mostly $> 300 \mu\text{m}$) size detection and procedural contamination which can compromise the results. Researchers began to look at alternative methods of analysis, such as the use of seawater intakes on research vessels, submersible pumps and use advanced sensor systems (e.g. FerryBox) to collect large volume samples of which several have shown promise for their use.^[6-9]

Academic, non-profit, government and non-governmental organizations have all become engaged in microplastic research: through the development of methods as well as the inclusion of microplastic sampling into ongoing monitoring programs and strategic projects. As the knowledge surrounding microplastic assessment has increased, researchers have turned their attention to defining methods which allow the collection of robust data with quality an essential consideration for project design.^[10-12] There is a strong focus towards the production of quality controlled and quality assured (QA/QC) data, with limited sample manipulation and a general need for automated methods of detection.^[13, 14] Currently no sensors or on-line measuring technologies exist due to the large sample volumes needed, pre-concentration of the samples and often large amounts of biological interferences. Therefore, data generation relies on sound sampling methodologies and analytical processing in the laboratory. Limitations to comparative data generation cover themes such as the inclusion and exclusion of certain sizes, sample contamination, inconsistent units of reporting, lack of validation in processing methods, accuracy or representativeness of samples and validation of observed/visual results using

analytical techniques.^[15] In the following document, the approaches to seawater microplastic assessment are presented with a view towards methods harmonization and minimum requirements for comparative data generation.

Field sampling for microplastics in seawater

Collection of representative samples is of utmost importance. Much literature has assessed the use of different sampling approaches to seawater (Table 1), and the current limiting factor is the collection of large enough volumes to generate a representative sample. Further, when sampling in areas of high biological activity, the samples may be compromised by large amounts of organic matter clogging the collection devices. This is especially true when using small mesh sizes.^[12, 16]

Net sampling

This approach is by far the most commonly applied technique for sampling surface water (manta or neuston nets), subsurface waters and the water column (neuston or bongo nets). Nets are towed in surface waters or the water column for a set duration, rinsed on deck and any anthropogenic particles are categorized by morphology (size, shape, color) and sometimes weighed^[4, 5]. Many studies using nets sampling focus on the visible identification of the larger fraction of particle 1-5 mm, often these methods do not use spectroscopic confirmation and plastics are only identified with the naked eye. Although net sampling methods enable sampling of large volumes, the disadvantages are discriminating particles smaller than the nominal mesh size, sampling water volumes passing through the net can only be estimated, nets often bounce on the water surface in adverse weather conditions and it can be very difficult to prevent contamination from working on deck of vessels. Further, when clogging occurs the sample may not be representative. Therefore, it is important that samplers can as accurately as possible, estimate the volume of water which has passed through the net, with a flow meter, or through the calculation of distance travelled.^[12]

Bulk water samples

There are many approaches to collecting bulk water samples. A volume-reduced water sample consists of pumping water (manually or using a motor) through a filter and out through a flow meter. These samples can be collected from a variety of sampling platforms: large or small vessels, from static platforms and the shoreline. These approaches are generally used when targeting microplastics in the smaller size ranges < 300 µm. QA/QC procedures are fundamental from sample collection into processing, including field and laboratory procedural blanks, which are easier to achieve using bulk water sam-

ples. In most cases, samples may be volume reduced in the field where necessary, but the analysis of samples is conducted under controlled laboratory conditions. Researchers began taking bulk water samples using seawater intakes on research vessels in many of the world's oceans^[7-9] and have developed to filtering apparatus being incorporated into other seawater monitoring set up, such as the FerryBox system which are deployed on vessels of opportunity.^[6] The standard FerryBox system collects continuous data on temperature, salinity, fluorescence, turbidity, as well as nutrient analysis, continuous plankton recording. The incorporation of microplastics into these systems will allow comparative data generation which can be accurately coupled to the environmental parameters at the time of sampling. Another example of using vessels of opportunity was the inclusion of filtration apparatus on sailing vessels participating in the Volvo Ocean Race, 2017. Samples (n = 68) were collected on board Team AkzoNobel. The analysis was performed in the laboratory used a combination of Raman spectroscopy to identify the particles, and a camera for microplastics particle size.^[17] Smaller bulk water samples include the collection of seawater in CTD rosettes.^[9]

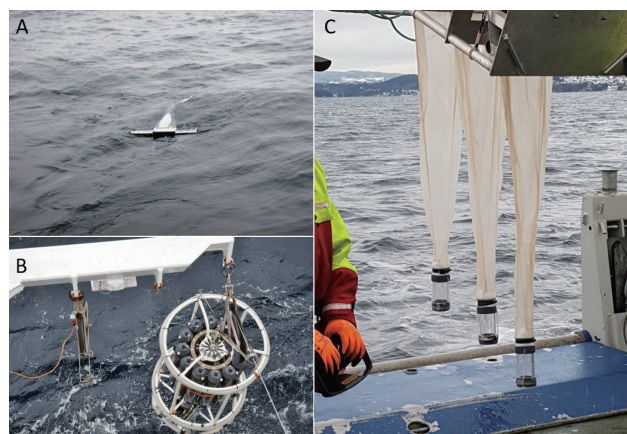

Figure 1 Sampling devices used for microplastic sampling in sea water, A: Manta net; B: CTD rosette bottles; C: multinet

Challenges of continuous measurement

Automated methods, such as continuous measurements, are advantageous as they can collect data without intervention. The representativeness of samples is often complicated by the distance travelled on large vessels or the volume sampled restricted by small water intakes (~in the range of a few cm). As often large volumes of water have to be sampled (> 1000 L), infrequent changing of filters could result in relatively large areas sampled (> 100 km). This is both an advantage, large trajectories can be sampled, but also a disadvantage if a small-scale special resolution is needed. Another challenge includes the presence

of organic material which can cause clogging and further compromise collected samples.^[12] Coupled with the need for changing filters, it is paramount that QA/QC is strict during sampling. Field blanks can be carried out to monitor the levels of airborne particles in samples, as well as the risk of contamination from the sampler or the equipment. Without these controls it is impossible for researchers to discern the true levels of microplastics in seawater as levels in the marine environment often are low. In summary, the steps made towards automated/semi-automated sample collection are promising, but far from having a readiness for worldwide implementation.

Table 1 Advantages and limitations of sampling approaches to seawater

	Advantages	Limitations
Surface water nets	Long term data sets Visual sorting possible with fraction >1 mm Sample large area	Surface samples only Weather dependent Estimated flow/volume Lower size limit often misses smaller particles (e.g. 300 µm)
Pumping systems - seawater intake e.g. FerryBox	Accurate flow/volume Large volume sampled	Subsurface only
Pumping systems - <i>In situ pumps</i>	Can be deployed at variable depths in the water column Accurate flow/volume Large volume sampled	Weather dependent
Bulk water samplers - CTD rosettes	Can be deployed at variable depths in the water column Can collect replicates	Low water volume (~20 litres)

Laboratory processing of seawater samples

Once samples have been collected from seawater, the analytical steps taken are critical to producing robust and comparative data. As with sample collection, a high level of QA/QC is recommended for studies reliant on laboratory and microscopy analysis. This allows the researchers to check the validity of any processing steps introduced before assessment and continue to monitor sources of procedural contamination. Depending on the interfering material collected on the sampling filters and the processing steps needed before the analysis are not discussed herein, the reader is referred to recent reviews on the matter.^[18]

A combination of approaches, from visual assessment with the naked eye through to automated spectroscopic methods can be used for the final analysis. A very recent critical assessment of the analytical methods associated to harmonized and coast efficient analysis of microplastics

has been published.^[3] This review presented the available techniques which includes naked eye detection, optical microscopy, uses of dyes and stains, flow cytometry, Fourier-Transform Infrared (FT-IR) spectroscopy and microscopy, Raman spectroscopy and microscopy and thermal degradation/desorption coupled to gas-chromatography/mass spectrometry. The methods chosen will impede the level of comparison between investigations. Especially when the aim is to quantify the presence of different plastic types. For example, when working with samples contaminating particles from 1-5 mm in size, researchers can use the unaided visual identification with a high level of confidence to identify plastics, but particles < 1 mm require more supported techniques (microscope plus analytical validation) to determine the presence of synthetic polymers as error values can reach up to 70%.^[3, 11, 12] Without polymer identification, this may lead to a high level of misidentification, especially when particles size is below 50-100 µm. As such, the use of spectroscopic methods is strongly recommended when working with the identification of microplastics < 1 mm, and fundamental for particles < 100 µm.

FT-IR and Raman spectroscopic methods allow the identification of particle composition by producing a fingerprint spectrum which is unique to different materials. Such that plastic spectra can be differentiated from those produced by natural materials. FT-IR and Raman are both complementary techniques, as molecular vibrations which are inactive with FT-IR, can be active for Raman, and vice versa. Spectroscopic methods can also be coupled to microscope set ups, allowing the application of polymer identification to small particles (µFT-IR ca. 10 µm, µRaman ca. 1 µm).^[3] When particles are preselected for FT-IR/Raman using optical light-microscopy by the operator, this can introduce a bias in the analysis, and in some instances transparent or translucent particles as well as very small particles might be overlooked during the preselection process.^[3] Hence, a reduced proportion of operator interference is encouraged, and researchers continue to seek advancements in µFT-IR and µRaman approaches. Often,

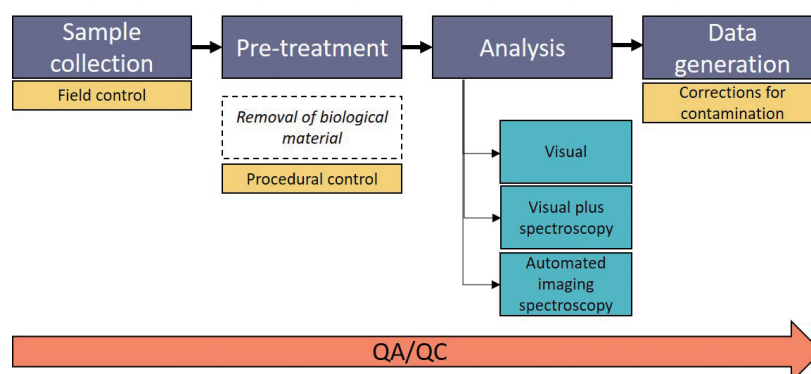

Figure 2 Schematic of steps required for comparative data generation

the use of spectroscopic methods is costly and time consuming, as such many studies use subsamples of representative particles.

To counteract this, automated spectral methods are being developed to enable high throughput of samples but are currently still limited to low sample volumes. Furthermore, the automatic samples analysis requires significant sample preparation and clean-up to be effective. Nevertheless, μ FT-IR has been seen to be a powerful tool and the atomization reduces time and demand of data generation.^[3] Providing the researchers are clear in their approach, choice of methods and use clear reporting guidelines, they can generate comparative data.

Conclusion

In the microplastics field of research there are many different sampling approaches and technologies available to investigate seawater microplastics. Developments are hampered by procedural contamination as microplastics and fibres can be introduced by the sampler, the air or sample equipment. This requires a thorough understanding of potential sources of error and effort to minimize intervention with samples in the field. A high level of QA/QC is required from collection through to data generation. This is especially important when studies reliant are reliant on laboratory/microscopy analysis. Method development is continuously ongoing to further automatize sampling, sample pretreatment and final analysis with a far greater attention to validation.

Acknowledgements

The author is grateful for comments provided by Professor Bert van Bavel (Norwegian Institute for Water Research, NIVA).

* This content is based on our investigation at the year of issue unless otherwise stated.

References

- [1] Carpenter, E.J. and Smith, K.L., 1972. Plastics on the Sargasso Sea surface. *Science*, **175**(4027), pp.1240-1241.
- [2] Cole, M., Lindeque, P., Halsband, C. and Galloway, T.S., 2011. Microplastics as contaminants in the marine environment: a review. *Marine Pollution Bulletin*, **62**(12), pp.2588-2597.
- [3] Primpke, S., Christiansen, S.H., Cowger, W., De Frond, H., Deshpande, A., Fischer, M., Holland, E., Meyns, M., O'Donnell, B.A., Ossmann, B. and Pittroff, M., 2020. EXPRESS: Critical Assessment of Analytical Methods for the Harmonized and Cost Efficient Analysis of Microplastics. *Applied Spectroscopy*, p.0003702820921465.
- [4] Law, K.L., Morét-Ferguson, S., Maximenko, N.A., Proskurowski, G., Peacock, E.E., Hafner, J. and Reddy, C.M., 2010. Plastic accumulation in the North Atlantic subtropical gyre. *Science*, **329**(5996), pp.1185-1188.
- [5] Law, K.L., Morét-Ferguson, S.E., Goodwin, D.S., Zettler, E.R., DeForce, E., Kukulka, T. and Proskurowski, G., 2014. Distribution of surface plastic debris in the eastern Pacific Ocean from an 11-year data set. *Environmental Science & Technology*, **48**(9), pp.4732-4738.
- [6] Conchubhair, D.Ó., Fitzhenry, D., Lusher, A., King, A.L., van Emmerik, T., Lebreton, L., Ricaurte-Villota, C., Espinosa, L. and O'Rourke, E., 2019. Joint effort among research infrastructures to quantify the impact of plastic debris in the ocean. *Environmental Research Letters*, **14**(6), p.065001.
- [7] Desforges, J.P.W., Galbraith, M., Dangerfield, N. and Ross, P.S., 2014. Widespread distribution of microplastics in subsurface seawater in the NE Pacific Ocean. *Marine Pollution Bulletin*, **79**(1-2), pp.94-99.
- [8] Lusher, A.L., Burke, A., O'Connor, I. and Officer, R., 2014. Microplastic pollution in the Northeast Atlantic Ocean: validated and opportunistic sampling. *Marine Pollution Bulletin*, **88**(1-2), pp.325-333.
- [9] Kanhai, L.D.K., Gårdfeldt, K., Lyashevskaya, O., Hassellöv, M., Thompson, R.C. and O'Connor, I., 2018. Microplastics in sub-surface waters of the Arctic Central Basin. *Marine Pollution Bulletin*, **130**, pp.8-18.
- [10] Brander, S.M., Renick, V.C., Foley, M., Steele, C.L., Woo, M., Lusher, A., Carr, S., Helm, P., Box, C., Cherniak, S. and Andrews, R.C., 2020. February. Sampling and QA/QC, or how many blanks do I need?: A guide for scientists investigating the occurrence of microplastics across matrices. In Ocean Sciences Meeting 2020. AGU.
- [11] Isobe, A., Buenaventura, N.T., Chastain, S., Chavanich, S., Cózar, A., DeLorenzo, M., Hagmann, P., Hinata, H., Kozlovskii, N., Lusher, A.L. and Martí, E., 2019. An interlaboratory comparison exercise for the determination of microplastics in standard sample bottles. *Marine Pollution Bulletin*, **146**, pp.831-837.
- [12] Michida, Y., Chavanich, S., Cabañas, A.C., Hagmann, P., Hinata, H., Isobe, A., Kershaw, P., Kozlovskii, N., Li, D., Lusher, A.L. and Martí, E., 2019. Guidelines for Harmonizing Ocean Surface Microplastic Monitoring Methods.
- [13] Hermsen, E., Mintenig, S.M., Besseling, E. and Koelmans, A.A., 2018. Quality criteria for the analysis of microplastic in biota samples: a critical review. *Environmental Science & Technology*, **52**(18), pp.10230-10240.
- [14] Koelmans, A.A., Nor, N.H.M., Hermsen, E., Kooi, M., Mintenig, S.M. and De France, J., 2019. Microplastics in freshwaters and drinking water: Critical review and assessment of data quality. *Water Research*.
- [15] Shim, W.J., Hong, S.H. and Eo, S.E., 2017. Identification methods in microplastic analysis: a review. *Analytical Methods*, **9**(9), pp.1384-1391.
- [16] Karlsson, T.M., Kärrman, A., Rotander, A. and Hassellöv, M., 2020. Comparison between manta trawl and in situ pump filtration methods, and guidance for visual identification of microplastics in surface waters. *Environmental Science and Pollution Research*, **27**(5), pp.5559-5571.
- [17] https://www.geomar.de/index.php?id=4&no_cache=1&tx_ttnews%5bt_news%5d=5977&tx_ttnews%5bbackPid%5d=185&L=1
- [18] Lusher, A.L., Munno, K., Hermabessiere, L., Carr, S. Isolation and Extraction of Microplastics from Environmental Samples: An Evaluation of Practical Approaches and Recommendations for Further Harmonisation. Accepted, *Applied Spectroscopy* (April 20th 2020).

Understanding the Nature of Microplastic Pollution and Identifying Environmental Impacts

Bridget O'DONNELL

With the large-scale production of consumer plastics, comes the problem of how to deal with the disposal of long-lived single use items. Only a small percentage of plastics are recycled, leaving a significant volume accumulating in landfills or polluting our environment, where they fragment into smaller pieces, termed microplastics. Microplastics are ubiquitous and are present in every part of the environment and in the tissue of organisms, where they have physical and chemical toxic effects. To understand the extent of the problem, it is important to formulate standard methods for the collection, extraction, and identification of microplastics. In addition, laboratory-based research must be performed to understand the capacity of microplastics to effect human and environmental health. This review paper summarizes some of the key research direction in this field, in particular with respect to the research laboratories of Dr. Chelsea Rochman at the University of Toronto, one of the world's leading authorities on microplastic analysis and understanding of environmental and health impacts and risks.

Introduction

Starting in the mid-twentieth century, plastics began to replace other materials, since they were easy and inexpensive to manufacture, while still being strong and durable. With the advent of plastics, came the idea of “throwaway living”: the idea that consumers could save time through single-use items including tableware and flatware, beverage and food containers, and diapers.^[1] With the increase in manufacturing of disposable consumer products, the production of plastics has ballooned since 1950, with an estimated 8,300 million metric tons produced as of 2015. Of that amount, only 30% of manufactured plastics are still in use, while approximately 60% have been discarded and 10% have been incinerated.^[2] The same characteristics that make plastics excellent materials for a wide variety of consumer uses, also make managing their disposal difficult. Lifetimes of plastics can range from tens of years to hundreds of years depending on the nature of the material.^[3] Depending on the implementation of waste management standards, plastic waste may be landfilled, incinerated, recycled, or dumped into the environment. Evidence of plastic pollution has been well documented from the Great Pacific Garbage Patch^[4] to “pristine” beaches littered with plastic trash.^[5]

Plastic litter comprises a wide variety of materials and

sizes, including microplastics, particles less than 5 mm in size.^[6] Sources of microplastics can be both primary and secondary. Primary sources include pellets from plastic processing plants, microbeads from cosmetic and personal care products, and industrial abrasives. Secondary sources of microplastics arise from the fragmentation and degradation of larger plastics. Examples include microfibers released from textiles and tire wear particles (see Figure 1).^[7] Microplastics encompass a wide variety of characteristics. Their morphologies include fibers, films, fragments, pellets, foams, and spheres.^[8] Microplastics also incorporate a wide variety of polymers including polyethylene (PE), polyethylene terephthalate (PET), polypropylene (PP), polystyrene (PS), polyvinyl chloride (PVC), and rubber. Microplastics are also not composed of polymers alone, but may also contain pigments or dyes and additives such as titanium dioxide and calcium carbonate. The transport of microplastics to the environment can occur through a variety of mechanisms, including through air and water, for example from laundering effluent and exhaust.^[9] Sinks of microplastics in the environment include sediment, freshwater bodies (lakes, rivers), and saltwater bodies (surface water, arctic ice).^[10] They can also be transported between organisms, for example from prey to predator, via trophic transfer.^[11] Microplastics have been found in nearly every level of the food chain from invertebrates^[12] all the way up to the largest mam-

Microplastics everywhere

High amounts of microplastics have been found not just in the sea and on beaches, but also in rivers and soils around the world, demonstrating how pervasive this modern pollution is. Sources include leakage from landfills, plasticulture, littering, and sewage sludge. Data from (1).

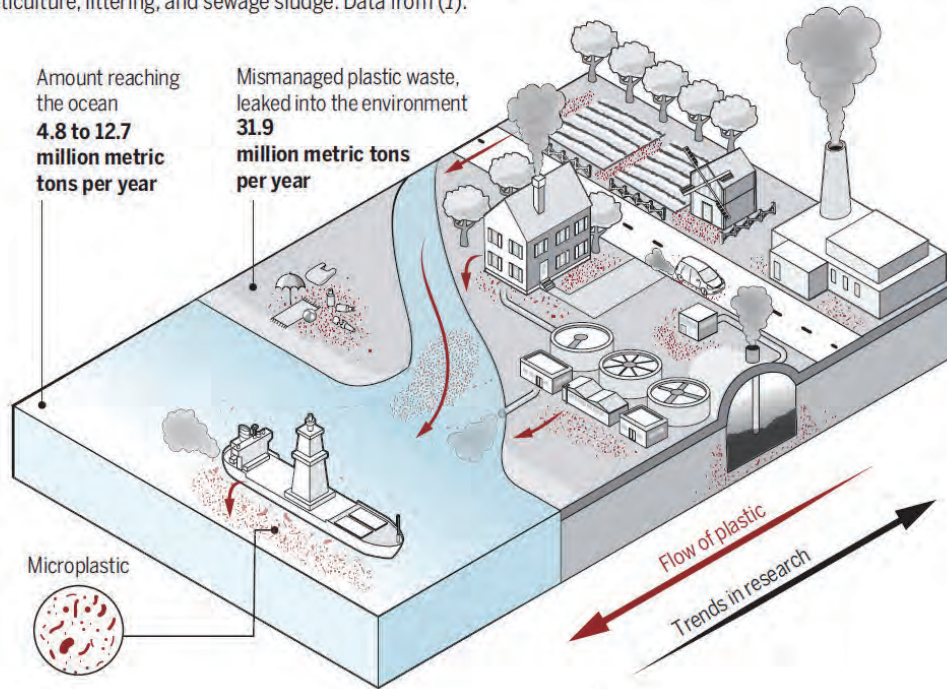

Figure 1 Reprinted with permission from Science Magazine (doi: 10.1126/science.aar7734).

mals on earth.^[13]

There is ample evidence in the literature that microplastics are harmful. Toxicity can take on two forms; physical and chemical. Physical toxicity arises from the accumulation of microplastics in organisms and can have a variety of effects on health, including reduced respiratory function, hepatic stress, and the formation of granulomas through immune response.^[14] As microplastics continue to break down into smaller and smaller fragments down to the nanoscale, translocation from the gut can occur leading to harmful effects in other tissues including the heart, lungs, gallbladder, and liver.^[15] Chemical toxicity can arise from either additives in the plastics themselves or through the accumulation of toxins like persistent organic pollutants (POPs) or metals on the surface of microplastic particles.^[14]

Critical to understanding the source of microplastics and potential toxicity is first understanding the presence and characteristics of microplastics in our environment. This includes elucidating the distribution of polymer types, presence of additives, particle morphology, and size distribution. In order to develop a clear picture, methods for collection, extraction, and identification of microplastics must be developed and standardized (or at least harmonized for data synthesis).

Collection Methods

The most common method for the collection of microplastics from marine environments is the neuston net or Manta Trawl. Using this technique, a large volume of surface water can be sampled by towing the net via a boat. Designed for collecting plankton, the net's mesh size is generally in the range of 333-335 μm, so the size of microplastics collected is restricted to those in the larger size range. However, microfibers, which are thought to be one of the most prevalent microplastic morphologies, can slip easily through a net, in addition to any other particulate with ellipsoidal shapes (thin fragments or folded/rolled films). Finally, the material of the net itself may contribute to contamination in collected samples.^[16] Another method for collection from marine environments is the grab method. In this method, a 1 L (or larger volume) sample of water is collected, typically in a glass or metal sample container, to avoid contamination. Although the total volume is less than a net, a grab sample can collect plastics down to the sub-micron scale. In addition, because of the simplicity of collection, researchers of any skill level can easily collect samples, including citizen scientists. Samples may also be collected from a variety of environments including shallow tidal pools and wastewater outflow sites.^[17]

Sediment samples require alternate collection methods - these include collection from coastal beaches to the deep

sea. For sediment samples collected from the seabed, specialized equipment is required. These can include grab samplers which scoop a sample from the top layer of the sea floor (Van Veen, Ekman) and core samplers, which collect columns of sediment, retaining information on the numbers of microplastics in sediment as a function of depth. As in the case of nets, contamination from plastic core samplers is also a concern. Metal is an alternate choice, however the opacity of metal precludes the ability of the researcher to actively monitor the volume of sediment collected.^[18]

Other common matrices include biota, which consists of sampling animals from the environment to bring back to the lab for processing. In addition, air samples are also becoming more common and methods for collection continue to be developed to capture both wet and dry deposition.

Extraction Methods

During the collection of microplastic samples, particulate of other types may also be present including minerals, plant matter, biota, and other organic matter. There are a number of methods used to isolate microplastics of interest from other particulate including density separation and chemical digestion. Density separation is used to separate denser particulate (e.g., minerals, silica) from the more buoyant microplastics. In density separation, the mixed sample matrix is immersed in a prepared solution with high density. Those particles with lower density than the solution, including microplastics, float to the surface, while heavier particles sink to the bottom. The solution is allowed to rest for an extended period so that the denser particles have time to settle before carefully extracting the top portion of the sample containing 'floating' particles. This process may then be repeated, through the addition of fresh solution to the settled portion of the sample to ensure that all microplastics are collected. Different solutions with varying density can be prepared including sodium chloride, zinc chloride, calcium chloride, and sodium iodide.^[16]

A unique extraction procedure taking advantage of the hydrophobic nature of microplastics was developed and reported by the Rochman lab at the University of Toronto. In this procedure, magnetic iron nanoparticles are functionalized with hydrophobic hydrocarbon tails. These hydrophobic groups preferentially bind to microplastics, which can then be extracted using a neodymium magnet by swirling the magnet in the sample jar and then rinsing it into a clean reservoir. Recovery of microplastics from spiked samples is demonstrated on a variety of size ranges from less than 20 µm to greater than 1 mm. It was con-

cluded that magnetic extraction is beneficial as a secondary extraction technique after density separation or for samples that are relatively clean, as in drinking water.^[19] Chemical digestion may be used to remove organic material while leaving microplastic particles behind. These methods include wet peroxide oxidation, alkaline digestion, and acidic digestion. When employing chemical digestion, it is important to ensure that the biological tissue and plant matter are removed without effecting the microplastics being collected. Acidic digestion has been shown to break down certain polymers, including nylon, polyamide, and rubber.^[20] It has also been demonstrated in a publication by Munno *et al* that high temperatures generated during digestion (> 60°C) can result in the loss of some microplastics, particularly microbeads used in personal care products.^[21] For biological samples, including collection of microplastics from gastrointestinal (GI) tracts, an alternative extraction procedure was developed by the California Department of Public Health, in collaboration with the Rochman lab, to avoid damage to the microplastics under study and to ensure that no biological tissue remains adhered to the surface of the extracted microplastics. In this procedure, the GI tract is dissected, isolated, and sealed in a vial. The vial is then immersed in a water tank and subjected to bursts of ultrasonic waves, termed pulsed ultrasonic extraction (PUE). The sample is then poured through a 1 mm stainless steel sieve and then filtered using a 10 µm core polycarbonate filter. Compared to samples prepared using traditional KOH digestion, samples extracted using PUE showed much cleaner surfaces and resulted in better spectral matches to reference databases.^[22] For biota, biota can be extracted whole, or dissected to isolate the GI tract or target organs.^[23]

Once an environmental sample has been collected and extracted, it may be sorted into various size fractions. Sieve stacks are used to separate particles into different size fractions down to approximately 300 µm.^[24] For smaller particles, vacuum filtration with progressively smaller pore size membranes may be used. Large microplastics can easily clog filter membranes or obscure smaller particles if size fractioning is not employed. For particles greater than approximately 300 µm, samples may be manipulated manually using fine-tipped forceps, while smaller particles are more difficult to manipulate and can be analyzed directly from the filter membrane.^[16] The use of size fractioning provides an additional benefit of collecting particles of similar size, which makes manual sorting easier.

Due to the varied nature of techniques and differing laboratory conditions, it is important to follow standard QA/QC techniques to account for any contamination that may be introduced throughout the collection and extraction

process. To limit the amount of contamination, it is best to minimize both the number of people handling samples and the amount of time the sample is exposed to air. General QA/QC lab practices include maintaining clean work surfaces, avoiding synthetic clothing, covering samples whenever possible, and installing air filters in the laboratory. In addition, proper QC/QA procedures include the generation of blank samples both in the field at collection and in the laboratory during extraction, which are treated with the exact same procedure used for measured samples. The results of particles found in the blank measurements may then be subtracted from the sample measurements or reported for each study.^[8]

Detection and Identification Methods

Visual examination of extracted samples using a stereo zoom microscope is arguably the most prevalent technique for identifying microplastics. Using visual examination, a suspected microplastic can be characterized by color, and morphology. In addition, visual identification can be used to discriminate natural particles from anthropogenic particles. Different modes of imaging can help to improve contrast and aid in identification including reflected/transmitted light, polarized light microscopy, and dark field microscopy. Microscopy images of the particles can be taken and used to record measurements for exact particle dimensions with the implementation of software such as ImageJ.^[25] The reliability of visual examination alone to definitively identify microplastics is low: depending on the researcher, false negatives and positives may occur with varying frequency.^[24] The addition of fluorescent staining can improve identification using

optical microscopy. The most common stain used in the identification of microplastics is Nile Red, which binds to plastics in both exposure experiments in the lab and in environmental samples through hydrophobic interactions. Nile Red fluoresces at a variety of wavelengths and is dependent on the hydrophobicity of the microplastic particle's surface. However, certain types of plastics including polycarbonate, polyurethane, PET, and PVC display weak signals, while microplastic fibers are particularly difficult to stain.^[26] In response to these difficulties, alternate stains have been tested in the Rochman lab, including those designed specifically for textiles. For both laboratory tests and environmental samples, different dyes have been identified as promising stain alternatives (see Figure 2).^[27-29]

For definitive chemical identification, there are a number of techniques that may be used including pyrolysis gas chromatography-mass spectrometry (GC-MS), Fourier transform infrared spectroscopy (FT-IR), Raman spectroscopy, and scanning electron microscopy (SEM) plus energy dispersive x-ray spectroscopy (SEM/EDS). The application of these techniques has been described in detail elsewhere,^[24] therefore a short overview of each technique's use in microplastics research will be given here. Pyrolysis GC-MS works by thermally breaking down the sample under measurement: the masses of the daughter fragments are analyzed in the resulting pyrogram to elucidate the parent molecule. GC-MS is considered a "gold standard" in analytical labs and is a readily available piece of analytical instrumentation. Pyrolysis GC-MS provides simultaneous identification and quantification of microplastics in complex samples. Because of

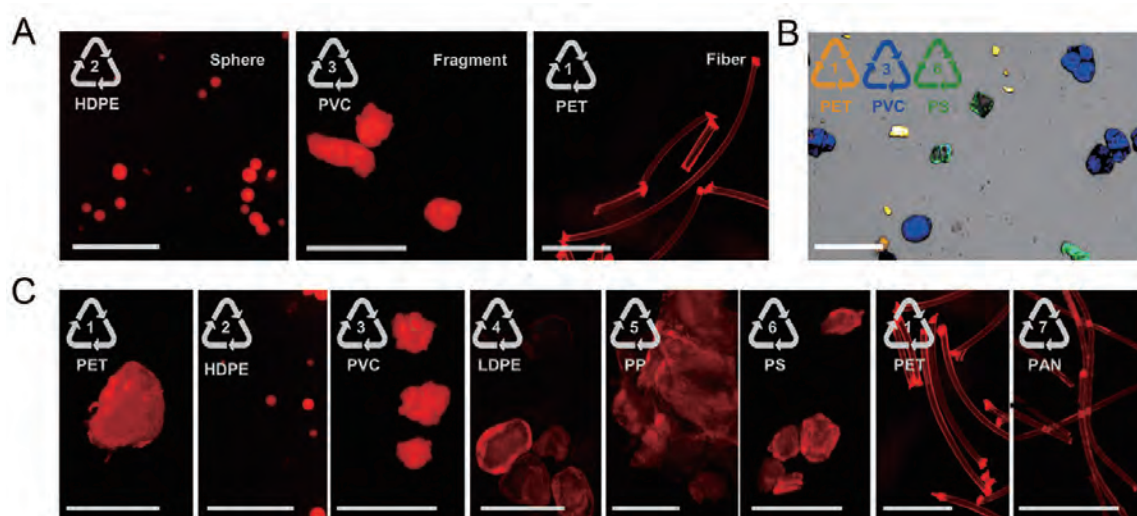

Figure 2 Examples of plastic types and morphologies dyed with different dyes. (A) Different morphologies: spheres (10-90 μm), fragments (50-300 μm), and fibers (30-60 μm /150-5000 μm) dyed with pink dye. (B) Different fluorophores: green (kentucky dye), red (pink dye), and far-red (blue dye). Pseudocolors are applied to different fluorescent channels for the purpose of differentiation. (C) Different polymer types dyed with pink dye: polyethylene terephthalate (PET) fragments (50-500 μm), high-density polyethylene (HDPE) spheres (10-90 μm), polyvinyl chloride (PVC) fragments (50-300 μm), low-density polyethylene (LDPE) fragments (100-500 μm), polypropylene (PP) fragments (500-4000 μm), polystyrene (PS) fragments (100-300 μm), polyester (PET) fiber (30-60 μm /150-5000 μm), and polyacrylonitrile (PAN) fiber (20-50 μm /300-3000 μm). Scale bars are 550 μm . Reprinted with permission from Environmental Science & Technology Letters (doi: 10.1021/acs.estlett.9b00241) Copyright (2019) American Chemical Society.

the quantitative nature of this technique (in mass, not number of particles), there is risk of matrix effects from remaining organic matter and materials or chemicals from extraction techniques, so extra care must be taken to accommodate for potential contaminants.^[24]

Raman spectroscopy and FT-IR spectroscopy are both techniques that probe the vibrational bonds in a molecule. FT-IR uses broadband infrared light to illuminate a sample; when the light is resonant with a vibrational band in the molecule under study, a decrease in the intensity of the infrared light is observed. In Raman spectroscopy, a monochromatic laser source illuminates the sample; most of the light is elastically scattered (Rayleigh scattering), while a small portion of light is inelastically scattered to lower or higher frequency (Stokes and anti-Stokes scattering). The difference in energy between the inelastically scattered photon and the laser corresponds to a vibrational band in the molecule under study. These two vibrational spectroscopy techniques are complementary and provide different structural information on the particle under study. For example, Raman active vibrational modes can provide information on the backbone of a polymer, while infrared active vibrational modes provide information on side chains. In addition, Raman spectroscopy can provide information on additives and pigments or dyes in microplastics, which can help in tracking the source of microplastics. While micro-FT-IR spectroscopy can measure a minimum particle size of approximately 10 μm , Raman spectroscopy can measure particles down to < 1 μm in size.^[24] For microplastics, this is critically important because it is generally agreed that, as particle sizes become smaller, the abundance of microplastics increases. Smaller particle sizes also have bigger ramifications when it comes to toxicology, which will be discussed in more detail below.^[24,30,31]

SEM/EDS combines scanning electron microscopy and energy dispersive x-ray spectroscopy to provide high resolution imaging at the nanoscale with elemental characterization of heavier elements. SEM focuses an electron beam onto the sample under study and measures the resulting scattered electrons. EDS works in combination with SEM and measures the resulting x-ray radiation from the sample. SEM/EDS provides a means to quickly distinguish plastics from minerals, which in marine environments, are primarily Si (sand) and Ca (shell fragments).^[22,24] Each technique described above has advantages, disadvantages, and varying associated costs and measurement times. In the characterization of microplastics, it is important to note that multiple techniques may be required for complete characterization.^[24] It is also important to standardize methods across different laboratories to ensure consistency in reporting. This is one of the main

goals of the microplastics study plan organized by the Southern California Coastal Water Research Project (SCCWRP) described in a separate article.

As a single microplastics sample can contain hundreds or thousands of particles, a critical part of the process of standardization is automation of sample measurements, in order to reduce the time required for sample analysis. One such method of automation relies on the use of the optical image of a sample, for example microplastic particulate on a filter membrane, to distinguish particles from the background substrate. The optical image provides the spatial contrast needed to identify the particulate, and then the use of a motorized stage together with Raman or FT-IR spectroscopy allows the user to collect spectra at each isolated particle. Using this technique, large areas can be covered without collecting spectra from areas that are not of interest, for example from the filter membrane itself.^[32]

While automated routines like those described above are sufficient for analysis of larger microplastics across an entire filter membrane (for example a 47 mm diameter filter), for analysis of particulate in the lower size range, < 20 μm , measurements across an entire filter becomes prohibitively expensive in both time and data size. As part of standardizing the analysis of microplastics, it is important to formulate sampling and sub-sampling schemes that are representative of the sample under study. There are a number of different ways to define sub-sampling, for example, by percentage of filter area covered in a measurement, or by the percentage of total particles measured. In a paper published by Anger *et al*, it was proposed that sub-sampling by percentage of total particles is most appropriate for two reasons; one, particles may not be evenly distributed across the filter and two, different filter diameters may be used across different laboratories. The proposed working method was to first estimate the total number of particles on a filter using the optical image, and then chemically identify a chosen subset of particles.^[33]

Once spectroscopic measurements are complete, it is necessary to determine the number of unique components present. Understanding the complete picture of chemical signatures can provide indication of the source of microplastics and potentially provide information on possible contamination as well (see Toxicology section).^[6] Multivariate analysis techniques including principal component analysis (PCA), multivariate curve resolution (MCR), and cluster analysis techniques can be used to determine the number of unique spectral signatures in a sample set.^[34] Once a model has been built, spectral matching algorithms may be used to identify the exact species present in a microplastics sample. The development of spectral

In a laboratory-based study by Rochman *et al*, the effects of bioaccumulation were tested using Japanese medaka. In this study, three groups of fish were studied; a control group, a group fed virgin LDPE, and a group fed LDPE that had been deployed in an urban bay. After one and two months of exposure, the amount of polycyclic aromatic hydrocarbons (PAH), polychlorinated biphenyls (PCB), and polybrominated diphenyls (PBDE) were tracked in the tissue of the fish. The results showed that not only does bioaccumulation of chemical pollutants occur, but signs of liver toxicity and pathology arise in the groups fed both virgin and deployed LDPE, namely glycogen depletion, fatty vacuolation, and single cell necrosis (in deployed LDPE only). This study demonstrated that (1) bioaccumulation of chemical pollutants through exposure to microplastics occurs in aquatic organisms and (2) exposure to microplastics and associated chemicals may induce hepatic stress.^[40]

While evidence for harm from microplastics in marine life has been well documented,^[12,39-44] less well understood is the effect that microplastics may have on humans. It is clear that microplastics are found in food consumed, including a variety of species of marine organisms,^[45] salt,^[46] and canned fish.^[47] An example of a potential route of exposure through seafood is shown in Figure 5.^[14] What happens once microplastics are consumed is not entirely clear. It is likely that many microplastic fragments are passed as waste, but this does not negate the possibility of physical and chemical toxicity in humans. A well-known example of the effect of chemical toxicity from

plastic packaging is bisphenol-A (BPA), a constituent monomer of polycarbonate. It was demonstrated that higher levels of BPA present in urine samples were associated with reported heart disease in American adults.^[48] Further research is needed to understand the amount of microplastics consumed, associated chemical exposure, and what health effects arise from such exposure.^[14]

Mitigation

To address the global problem of microplastics, governments around the world have begun to enact policies to deal with the staggering problem of plastic pollution. This includes the ban of microbeads from personal care products, the tracking of municipal or commercial waste, and commitments to reduce marine debris.^[14] From an industrial perspective, companies have started to implement sustainability practices including manufacturing products from plastics collected from beaches^[49], moving towards biodegradable or compostable materials,^[50] and transitioning to durable, multi-use packaging.^[51] Beach clean-up programs organized by non-governmental organizations (NGO) serve two purposes; to raise awareness of the problem of plastic marine debris and to help remove larger plastics that have the potential to become smaller microplastics.^[52] For consumers, there are also strategies that can be used daily to reduce microplastics. While reducing plastic use in general is a good first step (especially single-use plastic items), other sources of microplastics can be addressed in different ways. For example, microfibers from textiles are likely a large contributor to micro-

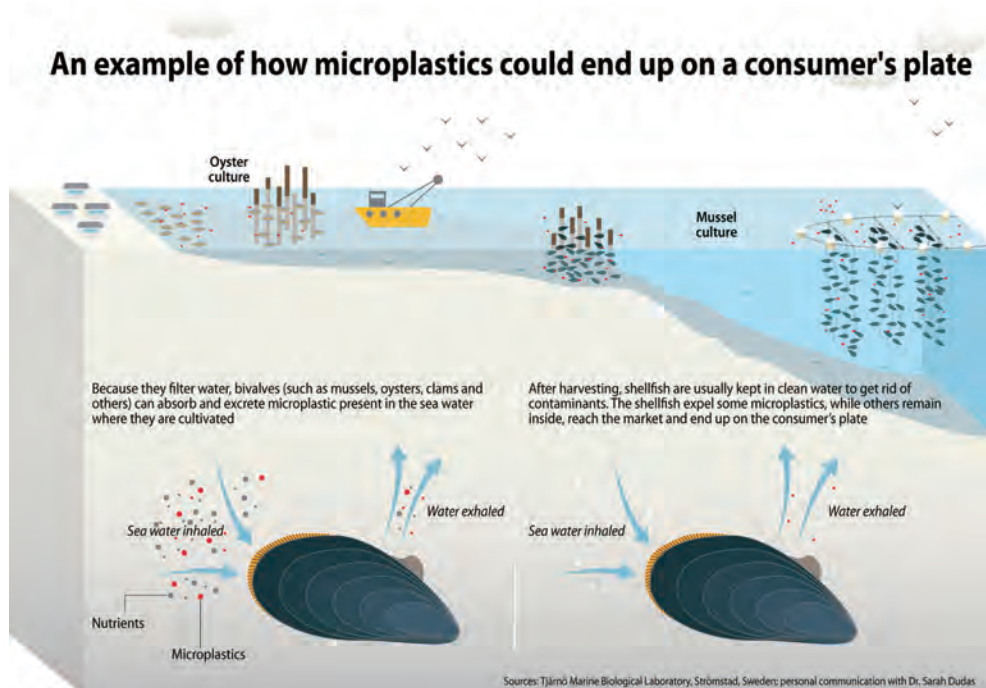

Figure 5 An example of how microplastics could end up on a consumer's plate. Reprinted with permission from Current Environmental Health Reports (doi: 10.1007/s40572-018-0206-z).

plastics emissions, where hundreds to thousands of microplastics are generated through the washing of a single garment.^[53] Products like the Lint LUV-R filter and CORA ball can help to trap microplastic fibers before they reach wastewater treatment plants, and ultimately are discharged into bodies of water.^[9]

Conclusion

Microplastic pollution is a global issue and one of the first steps in addressing the problem is to understand the nature of microplastics. This includes elucidating the major sources and sinks of microplastics in the environment, types of plastics and additives, and the particle morphologies and sizes. Optimization and standardization of laboratory methods for microplastic analysis is critical for reproducibility amongst labs including sample collection, extraction, detection, and identification methods. From this information, researchers can understand more about the sources of microplastics and how best to mitigate the threat to the environment and potentially to human health as well. The work of research laboratories like that of the Rochman group are critical to help drive standardized methodologies and a true understanding of the impact of microplastics and nanoplastics on our environment and health. Only through the development of harmonized reproducible methodologies will government agencies be able to provide the necessary recommendations to state and federal legislative bodies to put in place mandated monitoring and control programs.

Acknowledgements

I would like to thank Dr. Chelsea Rochman and all of the members of her research group for their efforts in the field of microplastics research; Keenan Munno, Hannah De Frond, Clara Thaysen, Nicholas Tsui, Alice Zhu, Rachel Giles, Kennedy Bucci, Lisa Erdle, Bonnie Hamilton, Samantha Athey, Lingyun Li, Ludovic Hermabesierre, Stephanie Borrelle, Anna O'Brien, Leah Chibwe, Jan Bikker, Hayley McIlwraith, Arielle Earn, Miguel Felismino, Anthony Carrozzi, Lara Werbowska, Dorsa Nouri Parto, Lauren Ead, Susan Debrecini, Raefaela and F. Gutierrez. I would also like to acknowledge Dr. David Sinton and members of his research lab for their contributions.

* This content is based on our investigation at the year of issue unless otherwise stated.

References

- [1] Life magazine. Throwaway Living: Disposal Items Cut down Household Chores. *LIFE*. August 1, 1955, p 43.
- [2] Geyer, R.; Jambeck, J. R.; Law, K. L. Production, Use, and Fate of All Plastics Ever Made. *Sci. Adv.* 2017, **3** (7), e1700782. <https://doi.org/10.1126/sciadv.1700782>.
- [3] National Oceanic and Atmospheric Administration. Can marine debris degrade on its own in the environment? <https://oceanservice.noaa.gov/facts/degrade.html> (accessed Apr 15, 2020).
- [4] Moore, C.; Phillips, C. *Plastic Ocean: How a Sea Captain's Chance Discovery Launched a Quest to Save the Oceans*, First trade paperback edition 2012.; Avery a member of Penguin Group (USA): New York, 2012.
- [5] Lavers, J. L.; Bond, A. L. Exceptional and Rapid Accumulation of Anthropogenic Debris on One of the World's Most Remote and Pristine Islands. *Proc Natl Acad Sci USA* 2017, **114** (23), 6052-6055. <https://doi.org/10.1073/pnas.1619818114>.
- [6] Arthur, C., J. Baker and H. Bamford. *Proceedings of the International Research Workshop on the Occurrence, Effects and Fate of Microplastic Marine Debris*; Technical Memorandum NOS-OR & R-30; National Oceanic and Atmospheric Administration, 2009.
- [7] GESAMP. *Sources, Fate and Effects of Microplastics in the Marine Environment: Part Two of a Global Assessment*; **93**; IMO/FAO/UNESCO-IOC/UNIDO/WMO/IAEA/UN/ UNEP/UNDP Joint Group of Experts on the Scientific Aspects of Marine Environmental Protection, 2016; p 220.
- [8] Rochman, C. M.; Brookson, C.; Bikker, J.; Djuric, N.; Earn, A.; Bucci, K.; Athey, S.; Huntington, A.; McIlwraith, H.; Munno, K.; De Frond, H.; Kolomijeca, A.; Erdle, L.; Grbic, J.; Bayoumi, M.; Borrelle, S. B.; Wu, T.; Santoro, S.; Werbowska, L. M.; Zhu, X.; Giles, R. K.; Hamilton, B. M.; Thaysen, C.; Kaura, A.; Klasios, N.; Ead, L.; Kim, J.; Sherlock, C.; Ho, A.; Hung, C. Rethinking Microplastics as a Diverse Contaminant Suite. *Environ Toxicol Chem* 2019, **38** (4), 703-711. <https://doi.org/10.1002/etc.4371>.
- [9] McIlwraith, H. K.; Lin, J.; Erdle, L. M.; Mallos, N.; Diamond, M. L.; Rochman, C. M. Capturing Microfibers - Marketed Technologies Reduce Microfiber Emissions from Washing Machines. *Marine Pollution Bulletin* 2019, **139**, 40-45. <https://doi.org/10.1016/j.marpolbul.2018.12.012>.
- [10] Rochman, C. M. Microplastics Research—from Sink to Source. *Science* 2018, **360** (6384), 28-29. <https://doi.org/10.1126/science.aar7734>.
- [11] Provencher, J. F.; Ammendolia, J.; Rochman, C. M.; Mallory, M. L. Assessing Plastic Debris in Aquatic Food Webs: What We Know and Don't Know about Uptake and Trophic Transfer. *Environ. Rev.* 2019, **27** (3), 304-317. <https://doi.org/10.1139/er-2018-0079>.
- [12] Thaysen, C.; Stevack, K.; Ruffolo, R.; Poirier, D.; De Frond, H.; DeVera, J.; Sheng, G.; Rochman, C. M. Leachate From Expanded Polystyrene Cups Is Toxic to Aquatic Invertebrates (Ceriodaphnia Dubia). *Front. Mar. Sci.* 2018, **5**, 71. <https://doi.org/10.3389/fmars.2018.00071>.
- [13] Lusher, A. L.; Hernandez-Milian, G.; O'Brien, J.; Berrow, S.; O'Connor, I.; Officer, R. Microplastic and Macroplastic Ingestion by a Deep Diving, Oceanic Cetacean: The True's Beaked Whale *Mesoplodon Mirus*. *Environmental Pollution* 2015, **199**, 185-191. <https://doi.org/10.1016/j.envpol.2015.01.023>.
- [14] Smith, M.; Love, D. C.; Rochman, C. M.; Neff, R. A. Microplastics in Seafood and the Implications for Human Health. *Curr Envir Health Rpt* 2018, **5** (3), 375-386. <https://doi.org/10.1007/s40572-018-0206-z>.
- [15] Stapleton, P.; 1 Department of Pharmacology and Toxicology, Ernest Mario School of Pharmacy, Rutgers University, 160 Frelinghuysen Rd., Piscataway, NJ 08854, USA; 2 Environmental and Occupational

- Health Sciences Institute, 170 Frelinghuysen Rd., Piscataway, NJ 08854, USA. Toxicological Considerations of Nano-Sized Plastics. *AIMS Environmental Science* 2019, **6** (5), 367-378. <https://doi.org/10.3934/environsci.2019.5.367>.
- [16] Prata, J. C.; da Costa, J. P.; Duarte, A. C.; Rocha-Santos, T. Methods for Sampling and Detection of Microplastics in Water and Sediment: A Critical Review. *TrAC Trends in Analytical Chemistry* 2019, **110**, 150-159. <https://doi.org/10.1016/j.trac.2018.10.029>.
- [17] Barrows, A. P. W.; Neumann, C. A.; Berger, M. L.; Shaw, S. D. Grab vs. Neuston Tow Net: A Microplastic Sampling Performance Comparison and Possible Advances in the Field. *Anal. Methods* 2017, **9** (9), 1446-1453. <https://doi.org/10.1039/C6AY02387H>.
- [18] Tsuchiya, M.; Nomaki, H.; Kitahashi, T.; Nakajima, R.; Fujikura, K. Sediment Sampling with a Core Sampler Equipped with Aluminum Tubes and an Onboard Processing Protocol to Avoid Plastic Contamination. *MethodsX* 2019, **6**, 2662-2668. <https://doi.org/10.1016/j.mex.2019.10.027>.
- [19] Grbic, J.; Nguyen, B.; Guo, E.; You, J. B.; Sinton, D.; Rochman, C. M. Magnetic Extraction of Microplastics from Environmental Samples. *Environ. Sci. Technol. Lett.* 2019, **6** (2), 68-72. <https://doi.org/10.1021/acs.estlett.8b00671>.
- [20] Enders, K.; Lenz, R.; Beer, S.; Stedmon, C. A. Extraction of Microplastic from Biota: Recommended Acidic Digestion Destroys Common Plastic Polymers. *ICES Journal of Marine Science* 2017, **74** (1), 326-331. <https://doi.org/10.1093/icesjms/fsw173>.
- [21] Munno, K.; Helm, P. A.; Jackson, D. A.; Rochman, C.; Sims, A. Impacts of Temperature and Selected Chemical Digestion Methods on Microplastic Particles: Impacts of Temperature and Digestion Method on Microplastics. *Environ Toxicol Chem* 2018, **37** (1), 91-98. <https://doi.org/10.1002/etc.3935>.
- [22] Wagner, J.; Wang, Z.-M.; Ghosal, S.; Rochman, C.; Gassel, M.; Wall, S. Novel Method for the Extraction and Identification of Microplastics in Ocean Trawl and Fish Gut Matrices. *Anal. Methods* 2017, **9** (9), 1479-1490. <https://doi.org/10.1039/C6AY02396G>.
- [23] Lusher, A. L.; Welden, N. A.; Sobral, P.; Cole, M. Sampling, Isolating and Identifying Microplastics Ingested by Fish and Invertebrates. *Anal. Methods* 2017, **9** (9), 1346-1360. <https://doi.org/10.1039/C6AY02415G>.
- [24] Primpke, S.; Christiansen, S. H.; Cowger, W.; De Frond, H.; Deshpande, A.; Fischer, M.; Holland, E.; Meyns, M.; O'Donnell, B. A.; Ossmann, B.; Pittroff, M.; Sarau, G.; Scholz-Böttcher, B. M.; Wiggin, K. EXPRESS: Critical Assessment of Analytical Methods for the Harmonized and Cost Efficient Analysis of Microplastics. *Appl Spectrosc* 2020, 0003702820921465. <https://doi.org/10.1177/0003702820921465>.
- [25] Rueden, C. T.; Schindelin, J.; Hiner, M. C.; DeZonia, B. E.; Walter, A. E.; Arena, E. T.; Eliceiri, K. W. ImageJ2: ImageJ for the next Generation of Scientific Image Data. *BMC Bioinformatics* 2017, **18** (1), 529. <https://doi.org/10.1186/s12859-017-1934-z>.
- [26] Stanton, T.; Johnson, M.; Nathanail, P.; Gomes, R. L.; Needham, T.; Burson, A. Exploring the Efficacy of Nile Red in Microplastic Quantification: A Costaining Approach. *Environ. Sci. Technol. Lett.* 2019, **6** (10), 606-611. <https://doi.org/10.1021/acs.estlett.9b00499>.
- [27] Karakolis, E. G.; Nguyen, B.; You, J. B.; Graham, P. J.; Rochman, C. M.; Sinton, D. Digestible Fluorescent Coatings for Cumulative Quantification of Microplastic Ingestion. *Environ. Sci. Technol. Lett.* 2018, **5** (2), 62-67. <https://doi.org/10.1021/acs.estlett.7b00545>.
- [28] Karakolis, E. G.; Nguyen, B.; You, J. B.; Rochman, C. M.; Sinton, D. Fluorescent Dyes for Visualizing Microplastic Particles and Fibers in Laboratory-Based Studies. *Environ. Sci. Technol. Lett.* 2019, **6** (6), 334-340. <https://doi.org/10.1021/acs.estlett.9b00241>.
- [29] Zhu, X.; Nguyen, B.; You, J. B.; Karakolis, E.; Sinton, D.; Rochman, C. Identification of Microfibers in the Environment Using Multiple Lines of Evidence. *Environ. Sci. Technol.* 2019, **53** (20), 11877-11887. <https://doi.org/10.1021/acs.est.9b05262>.
- [30] Araujo, C. F.; Nolasco, M. M.; Ribeiro, A. M. P.; Ribeiro-Claro, P. J. A. Identification of Microplastics Using Raman Spectroscopy: Latest Developments and Future Prospects. *Water Research* 2018, **142**, 426-440. <https://doi.org/10.1016/j.watres.2018.05.060>.
- [31] Käßler, A.; Fischer, D.; Oberbeckmann, S.; Schernewski, G.; Labrenz, M.; Eichhorn, K.-J.; Voit, B. Analysis of Environmental Microplastics by Vibrational Microspectroscopy: FTIR, Raman or Both? *Anal Bioanal Chem* 2016, **408** (29), 8377-8391. <https://doi.org/10.1007/s00216-016-9956-3>.
- [32] L., F.; I., P.-P.; J., M.; P., S.; C., L.; A., H.; E., R. A Semi-Automated Raman Micro-Spectroscopy Method for Morphological and Chemical Characterizations of Microplastic Litter. *Marine Pollution Bulletin* 2016, **113** (1-2), 461-468. <https://doi.org/10.1016/j.marpolbul.2016.10.051>.
- [33] Anger, P. M.; von der Esch, E.; Baumann, T.; Elsner, M.; Niessner, R.; Ivleva, N. P. Raman Microspectroscopy as a Tool for Microplastic Particle Analysis. *TrAC Trends in Analytical Chemistry* 2018, **109**, 214-226. <https://doi.org/10.1016/j.trac.2018.10.010>.
- [34] Shafer-Peltier, K. E.; Haka, A. S.; Motz, J. T.; Fitzmaurice, M.; Dasari, R. R.; Feld, M. S. Model-Based Biological Raman Spectral Imaging. *J. Cell. Biochem.* 2002, **87** (S39), 125-137. <https://doi.org/10.1002/jcb.10418>.
- [35] Munno, K.; De Frond, H.; O'Donnell, B.; Rochman, C. M. Increasing the Accessibility for Characterizing Microplastics: Introducing New Application-Based and Spectral Libraries of Plastic Particles (SLoPP and SLoPP-E). *Anal. Chem.* 2020, **92** (3), 2443-2451. <https://doi.org/10.1021/acs.analchem.9b03626>.
- [36] Rochman, C. M.; Hoh, E.; Hentschel, B. T.; Kaye, S. Long-Term Field Measurement of Sorption of Organic Contaminants to Five Types of Plastic Pellets: Implications for Plastic Marine Debris. *Environ. Sci. Technol.* 2013, 130109073312009. <https://doi.org/10.1021/es303700s>.
- [37] Halden, R. U. Plastics and Health Risks. *Annu. Rev. Public Health* 2010, **31** (1), 179-194. <https://doi.org/10.1146/annurev.publhealth.012809.103714>.
- [38] Koelmans, A. A. Modeling the Role of Microplastics in Bioaccumulation of Organic Chemicals to Marine Aquatic Organisms. A Critical Review. In *Marine Anthropogenic Litter*; Bergmann, M., Gutow, L., Klages, M., Eds.; Springer International Publishing: Cham, 2015; pp 309-324. https://doi.org/10.1007/978-3-319-16510-3_11.
- [39] *Marine Anthropogenic Litter*; Bergmann, M., Gutow, L., Klages, M., Eds.; Springer International Publishing: Cham, 2015. <https://doi.org/10.1007/978-3-319-16510-3>.
- [40] Rochman, C. M.; Hoh, E.; Kurobe, T.; Teh, S. J. Ingested Plastic Transfers Hazardous Chemicals to Fish and Induces Hepatic Stress. *Sci Rep* 2013, **3** (1), 3263. <https://doi.org/10.1038/srep03263>.
- [41] Rochman, C. M.; Parnis, J. M.; Browne, M. A.; Serrato, S.; Reiner, E. J.; Robson, M.; Young, T.; Diamond, M. L.; Teh, S. J. Direct and Indirect Effects of Different Types of Microplastics on Freshwater Prey (Corbicula Fluminea) and Their Predator (Acipenser Transmontanus). *PLoS ONE* 2017, **12** (11), e0187664. <https://doi.org/10.1371/journal.pone.0187664>.
- [42] Rochman, C. M.; Kurobe, T.; Flores, I.; Teh, S. J. Early Warning Signs of Endocrine Disruption in Adult Fish from the Ingestion of Polyethylene with and without Sorbed Chemical Pollutants from the Marine Environment. *Science of The Total Environment* 2014, **493**, 656-661. <https://doi.org/10.1016/j.scitotenv.2014.06.051>.
- [43] Gassel, M.; Rochman, C. M. The Complex Issue of Chemicals and Microplastic Pollution: A Case Study in North Pacific Lanternfish. *Environmental Pollution* 2019, **248**, 1000-1009. <https://doi.org/10.1016/j.envpol.2019.03.002>.
- [44] Rochman, C. M. The Role of Plastic Debris as Another Source of Hazardous Chemicals in Lower-Trophic Level Organisms. In

Hazardous Chemicals Associated with Plastics in the Marine Environment; Takada, H., Karapanagioti, H. K., Eds.; Springer International Publishing: Cham, 2016; Vol. **78**, pp 281-295. https://doi.org/10.1007/698_2016_17.

- [45] Collard, F.; Gilbert, B.; Compère, P.; Eppe, G.; Das, K.; Jauniaux, T.; Parmentier, E. Microplastics in Livers of European Anchovies (*Engraulis encrasicolus*, L.). *Environmental Pollution* 2017, **229**, 1000-1005. <https://doi.org/10.1016/j.envpol.2017.07.089>.
- [46] Karami, A.; Golieskardi, A.; Keong Choo, C.; Larat, V.; Galloway, T. S.; Salamatinia, B. The Presence of Microplastics in Commercial Salts from Different Countries. *Sci Rep* 2017, **7** (1), 46173. <https://doi.org/10.1038/srep46173>.
- [47] Karami, A.; Golieskardi, A.; Choo, C. K.; Larat, V.; Karbalaee, S.; Salamatinia, B. Microplastic and Mesoplastic Contamination in Canned Sardines and Sprats. *Science of The Total Environment* 2018, **612**, 1380-1386. <https://doi.org/10.1016/j.scitotenv.2017.09.005>.
- [48] Melzer, D.; Rice, N. E.; Lewis, C.; Henley, W. E.; Galloway, T. S. Association of Urinary Bisphenol A Concentration with Heart Disease: Evidence from NHANES 2003/06. *PLoS ONE* 2010, **5** (1), e8673. <https://doi.org/10.1371/journal.pone.0008673>.
- [49] Procter & Gamble. The world's first recyclable shampoo bottle made from beach plastic <https://www.headandshoulders.com/en-us/whats-new/new-head-shoulders-bottle-to-be-made-with-recycled-beach-plastic> (accessed Apr 16, 2020).
- [50] Dijkstra, H.; van Beukering, P.; Brouwer, R. Business Models and Sustainable Plastic Management: A Systematic Review of the Literature. *Journal of Cleaner Production* 2020, **258**, 120967. <https://doi.org/10.1016/j.jclepro.2020.120967>.
- [51] Terracycle. Loop <https://loopstore.com/> (accessed Apr 16, 2020).
- [52] National Oceanic and Atmospheric Administration. Marine Debris Program <https://marinedebris.noaa.gov/> (accessed Apr 16, 2020).
- [53] Hartline, N. L.; Bruce, N. J.; Karba, S. N.; Ruff, E. O.; Sonar, S. U.; Holden, P. A. Microfiber Masses Recovered from Conventional Machine Washing of New or Aged Garments. *Environ. Sci. Technol.* 2016, **50** (21), 11532-11538. <https://doi.org/10.1021/acs.est.6b03045>.



Bridget O'DONNELL, Ph.D.
Manager of Raman Applications
HORIBA Instruments Incorporated (HII)

Raman Applications on Microplastics

Eunah LEE

Bridget O'DONNELL

Andrew WHITLEY

Microplastics (MPs) is an emerging and rapidly growing research field, the potential for which the scientific impact and business opportunities are abundant. HORIBA is working with several key opinion leaders (KOLs) help develop and drive the critical thinking to establish analytical standards and regulation guidelines. The availability of harmonized methods and key instrumental and software capabilities will determine how well we can monitor and control MP pollution and health risks in the future. This paper will summarize ongoing collaboration projects with KOLs being performed by the HORIBA US Raman team, and what we've learned from this so far.

Introduction

It has been reported that less than 10% of manufactured plastics are recycled. With approx. 30% in use, this leaves 60% of plastics to be discarded into environment, or being incinerated. Discarded plastics take tens (e.g. plastic bags and foam cups) to hundreds (e.g. plastic bottles and disposable diapers) of years to decompose, accumulating on land, including in landfill sites, coastlines, in Arctic sea ice, and on the sea surface and floor.^[1] During these long years, plastics fragment into small particulates, forming microplastics (MPs) and nanoplastics (NPs). They are not only hazardous for wildlife, but also pose health risks for humans^[2] through air pollution (e.g. nanotoxicity due to inhaling NPs), water (e.g. MPs in drinking water) and food sources.

Governing bodies around the world have recognized the detrimental impact of MPs, and started implementing new regulations. Scientific guidelines are critical for effective regulation, and key opinion leaders (KOLs) are actively working to develop standard methods for sample

collection, preparation, analysis, and evaluation. HORIBA has been working with several KOLs to understand analytical requirements for MPs, including software and hardware optimization and automation. These efforts have been successful so far, resulting in various publications and presentations^[3]. There is however still a long way to go.

It has been demonstrated^[4] that using multiple technologies, including Raman microscopy, is essential to identifying MPs without ambiguity. Raman microscopy is growing in its importance due to its high spatial resolution (necessary for particles on the order of $\sim 10 \mu\text{m}$ and smaller), high tolerance toward wet samples (advantageous for field analysis), sensitivity to additives (useful for brand and source identification) and polymers (useful for chemical identification), and specificity for polymer type (for positive identification) and minerals (for exclusive identification). HORIBA Scientific's XploRA PLUS confocal Raman microscope is well equipped to handle MP analysis, and has been installed at multiple KOL laboratories, successfully proving its performance and usefulness. As



Figure 1 HORIBA Raman instruments. (a) XploRA PLUS, (b) MacroRAM and (c) XploRA Nano

research progresses, the demand for Raman analysis (and instruments) will expand to field analysis instruments (e.g. compact Raman spectrometer such as HORIBA's MacroRAM coupled with optical fiber probes), NPs analysis (e.g. AFM-Raman hybrid system) aided by nano-tags (e.g. nanoGPS), and multi-modal imaging and microscopy (e.g. epi-fluorescence and hyperspectral imaging microscopy). HORIBA is well placed to explore the business potential of MPs with its versatile collection of products.

Importance of collaboration

MP analysis is just emerging and rapidly growing as a research field; exponentially increasing in volume and importance as an application area and at critical timing as a business opportunity. Analytical requirements are not well determined, yet. Standards and regulations are yet to be defined. It is critical to work with KOLs to accumulate and exchange knowledge, learn requirements specific for MP analysis, establish Raman as a standard analysis technology for MPs, and establish and brand HORIBA as a go-to vendor for Raman analysis for MPs.

Collaboration with Prof. Chelsea Rochman, University of Toronto^[5]

Professor Rochman is a faculty member in the Department of Ecology & Evolutionary Biology at the University of Toronto. The ultimate goal of this collaboration is to develop an automated technique for handling small-size MPs (< 100 µm).

Automating MP analysis must be preceded by establishing standard operating procedures (SOPs). SOPs are critical in MP analysis because MPs migrate over a long distance (e.g. from river to ocean to shore), and require collective characterization by multiple research groups.

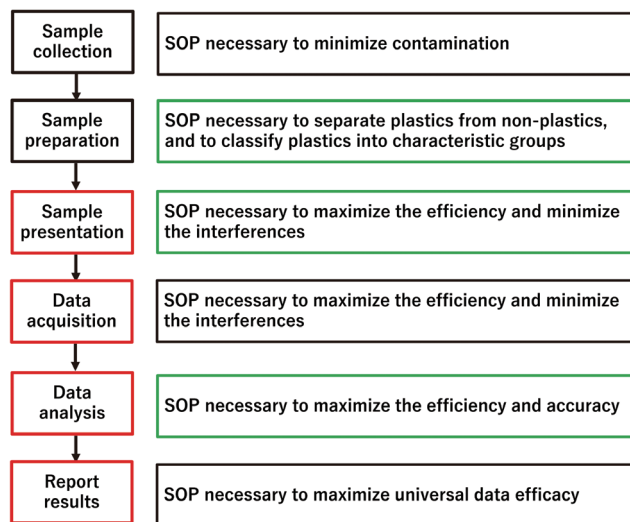

Figure 2 A flowchart of MP analysis. Items highlighted in red mark processes of high demand for automation. Items in green mark Rochman group research focuses at this time.

Unless every research group follows the same SOP, it will be impossible to combine/compare data, follow the plastics lifecycle as they migrate through the environment, or establish effective guidelines to minimize MPs in the environment.

Dr. Rochman's group has developed SOPs for sample preparation that include:

0. MPs are collected from various matrices (water, sediment, biota)
1. Acid, base, or enzymatic digestion is carried out to remove organic material
2. MPs are size fractionated using sieves down to 100 µm in size
3. Remaining small MPs are filtered into size groups down to 1 µm

When collected from the environment, MP samples contain inorganic materials (e.g. sand), organic materials (e.g. biofilm), and non-synthetic materials (e.g. natural fibers) along with MPs. SOPs developed by Dr. Rochman's group separate MPs from non-plastic materials (step 1 of SOP), and divide MPs into size groups (steps 2 and 3 of SOP). Step 2 divides MPs into multiple size categories using sieves, the smallest size category being 100 µm in diameter. Particles smaller than 100 µm are divided into multiple size categories using filters in step 3, the smallest size threshold being 1 µm in diameter. It is not an accident that size thresholds are set at 100 µm and 1 µm. 100 µm represents the smallest size a researcher with a reasonable training can handle manually (e.g. picking up with tweezers). In other words, step 2, with the smallest sieve, separates MPs that can be manually sorted from those too small for that, and designates them for further sample preparation in step 3. 1 µm represents the smallest size an optical microscope can detect, resolve, count, and measure. In other words, step 3, with the finest filter, separates MPs that can be analyzed with an optical microscope i.e. 1 µm or greater, from those too small for that, i.e. < 1 µm, and designates those < 1 µm for nanomaterial analysis by, for example, an atomic force microscope (AFM).

Dr. Rochman's group recognized the advantage of minimizing the number of sample transfers, and utilized filters as a substrate to present the sample to Raman microscopes. This opened the door to further research to optimize the filter material for step 3. Currently multiple filters, commercial and custom developed in the lab, are tested for their efficiency in terms of interference, cost, mass manufacturing, etc.

As the Rochman group's SOPs are being finessed for practicality, the volume of samples they analyze increases, and so do their data accumulation challenges. They have

started compiling accumulated data into Raman spectral libraries dedicated for MPs research called SLoPP (spectral library of plastic particles) and SLoPP-E (spectral library of plastic particles aged in environment)^[6]. SLoPP is made of pure and pristine MPs spectra, and SLoPP-E spectra of weathered MPs. These libraries are being continuously expanded.

Collaboration with Dr. Ashok Deshpande, NOAA and Dr. Jennifer Lynch, NIST

Raman is a relatively new technology for MP analysis, gaining recognition in recent years. It is important to evaluate a new technology with respect to existing technologies. For MP analysis, the two methods used are mainly pyrolysis gas chromatography-mass spectrometer (pyro-GC-MS) and Fourier transform infrared (FT-IR) spectroscopy. MP samples from Hawaii were analyzed by three technologies for comparison, each at a different laboratory using a different technology. The results proved not the superiority of a single technology but the importance of multi-technology analysis for accurate identification.

Dr. Jennifer Lynch of the Biochemical and Exposure Science Group of National Institute of Standards and Technology (NIST)^[8] is a Research Biologist at and co-director of Center for Marine Debris Research (Hawaii Pacific University). She provided samples in this collaboration, and her student Kayla Brignac performed the analysis using FT-IR.

Dr. Ashok Deshpande of National Oceanic and Atmospheric Administration (NOAA)^[9] is a Research Chemist at Northeast Fisheries Science Center (James J. Howard Marine Sciences Laboratory at Sandy Hook). He performed the analysis with pyro-GC-MS.

Dr. Bridget O'Donnell of HORIBA is Manager of Raman Applications at HORIBA Scientific (Piscataway, New Jersey). She coordinated the collaboration, and performed analysis using Raman.

- Identification was 'perfect' for approximately 70% of samples, all three technologies making the same identification, and boosting the confidence in the results by cross-validating each other.
- Identification was 'good' for approximately 10%



Figure 3 Photo of Hawaiian marine debris items, Windward Oahu beach. Kahuku Transect 1^[7]

Table 1 Comparison of pyro-GC-MS, FT-IR and Raman

	Raman	ATR-FT-IR	Pyro-GC-MS
Technology	Scattering technique	Absorption technique	Chromatographic technique
Sample	Little to no sample preparation	Sample mounted on diamond crystal and compressed	Sample is completely pyrolyzed (destroyed)
Advantages	Sensitive to molecular vibration based on change in polarizability Sensitive to polymer backbone structure Spatial resolution < 1 μm	Sensitive to molecular vibration based on change in dipole moment Sensitive to polymer side chains Extensive databases available	Sensitive to molecular structure based on breakdown into fragments Quantitative results
Disadvantages	Susceptible to background fluorescence	Susceptible to water absorption	Long measurement time Large sample volume
Analysis by	Bridget O'Donnell, HORIBA	Jennifer Lynch, NIST	Ashok Deshpande, NOAA

of samples, two technologies making the same identification. The third technology identifies these as a variety of or similar structure to the accurate identification.

- Identification was ‘poor’ for approximately 10% of samples, each technology making different identification.
- The remaining 10% of samples were identified by only one technology, the other two technologies failing to yield usable data.

Given the extreme heterogeneity of plastic products with diversity in manufacturing process, this is not surprising. It would be possible to improve these results with further analysis or additional analytical technologies, and calls for adding even more technologies for the MPs’ analytical tool box.

Collaboration with Southern California Coastal Water Research Project (SCCWRP)

Southern California Coastal Water Research Project (SCCWRP)^[10] is a public Research and Development agency that is leading the project to establish the guideline for MP analysis, which will become the standard method for California State Government regulations. Dr. Steve Weisberg (Executive Director) and Dr. Charles Wong (Department Head, Chemistry Department) initiated and organized a study plan to evaluate MP measurement methods. This is the first step in establishing standard measurement methods that every MP research group will share and follow. In this study plan, they invited researchers around the world, including HORIBA, to participate in drafting measurement methods. SCCWRP has completed drafting a proposal for the method, and is in the process of producing and distributing standard samples in clean water, dirty water, sediment, and biological tissue. Each of the participating laboratories will analyze standard samples with the proposed method, evaluate its practicality, and help finesse improvements. HORIBA contributes expertise on Raman spectroscopy by proposing an augmentation to the study plan, and will evaluate methods for automating MP analysis and for potential field analysis using optical probes.

In preparation for and as a part of the study plan, SCCWRP organized three events in 2019: a workshop and round table discussion in April, sample extraction and preparation training in October, and sample analysis training in November. HORIBA participated in all three events, playing a key role in the sample analysis training.

Many environmental researchers spend limited time in a chemical laboratory, and thus require training operating

analytical instruments. The training session at SCCWRP for sample analysis in November 2019 was dedicated to Raman microscopy (provided by HORIBA Scientific) and FT-IR microscopy (provided by Thermo-Fisher). Researchers from key regulatory (e.g. Environmental Protection Agency) and academic (e.g. California State Universities) institutes were present, and trained on Raman using HORIBA Scientific’s XploRA PLUS. Researchers will travel back to SCCWRP to perform Raman analysis as part of the study plan, when standard samples are distributed, using the XploRA PLUS.

Instrument requirements of Raman analysis for MP analysis

One of the biggest complexities of MPs (and NPs) analysis is the extremely wide size distribution, ranging from 5 mm to 1 μ m (and smaller). As mentioned above, one of the first steps of sample preparation SOPs are classifying MPs into size groups.

MacroRAM with BallProbe^[11] (by MarqMetrix) would be suitable to analyze large MPs (in the order of millimeters), especially for field screening. Handheld Raman may be an intuitive candidate for field screening, but is typically designed for bulk analysis. Its measurement spot may be too large for MPs. The focus point of BallProbe is small (in the order of 200-400 μ m), making it a good match for large MPs in size. The MacroRAM is small, light and rugged, and suitable to transport between field basecamps. There are no moving parts, so installation is minimal and alignment is not required: plug it in, and turn it on.

One of the important aspects when selecting a field unit is its compatibility to a lab unit. MPs are sent back to a lab for further analysis if their analysis results are unsatisfactory for various reasons (e.g. too small even for the BallProbe, inconclusive identification, possibility of toxicity, etc.). It simplifies data comparison when the field unit and the lab unit use the same software. HORIBA’s benchtop MacroRAM, just like all Raman instruments from HORIBA, uses the LabSpec 6 Spectroscopy Suite (LS6) software, making it easy and simple to compare data to those from a lab unit such as the XploRA PLUS.

XploRA PLUS confocal Raman microscope is well equipped to handle small MP analysis (typically smaller than 1 mm down to less than 1 μ m) with a fully featured optical microscope, multiple lasers, confocal spectrometer, motorized stage, and advanced software.

The first step of any analysis is to observe MPs to gauge its color, size, shape and texture. For small MPs (typically smaller than 1 mm), the observation requires an optical

microscope. Optical microscopy technologies are dedicated to improve the contrast and the image authenticity. It may sound simple, but it is not trivial to improve contrast or image authenticity. To improve the contrast, one must improve the signal-to-noise ratio (SNR), achieve the best possible focus, and be able to differentiate subtle differences in optical properties (e.g. color, refractive index, birefringence, etc.). To improve image authenticity, one must minimize interference such as ‘shadows’ from non-uniform illumination, artifacts and distortions from optics themselves, and aberrations from polychromatic light. HORIBA’s XploRA PLUS is compatible with all optical microscopy technologies such as darkfield (DF) imaging, polarized light microscopy (PLM), epi-fluorescence imaging, and hyperspectral imaging (HSI) microscopy, allowing the researcher to observe, analyze and classify MPs by their size, color, shape and texture. It is imperative to note that there is absolutely no sample transfer to utilize any or all of these multimodal imaging techniques, which improves the practicality, speed and reliability of correlated analysis immensely.

Chemical composition of synthetic plastics are complex with multiple polymers and additives^[12] such as stabilizers, flame retardants, pigments, reinforcements, etc. The complexity increases as MPs undergo weathering in environments, which changes the physical and chemical characteristics. It has been reported^[13] that the impact of weathering on MPs is significant, and that the accuracy improves a great deal when spectra from weathered MPs, as well as those from pristine plastics, are used in identification methods. Optimum experiment conditions, naturally, vary depending on MPs’ characteristics, the first of which is selecting the ‘right’ laser to suppress any fluorescence baseline. The XploRA PLUS can house three lasers from blue to near-infrared (NIR), and switch between them easily with a single click, making laser selection a quick and intuitive operation.

One of the most neglected steps in MP analysis is sample presentation. It is necessary to place MPs on some kind of substrate to present it to a Raman microscope. The substrate may be a petri dish, a glass slide or a filter on a filter holder. It is possible to get interference from substrates. For example, the substrate may be Raman active, and its spectral features mix with MP spectra. Confocality of the spectrometer suppresses signals from substrates by suppressing out of focus signal. The XploRA PLUS employs a true confocal optical design for the Raman scattering beam path, making it ideal to acquire ‘clean’ Raman spectra by minimizing non-sample signals.

As Dr. Andrew Whitley’s article in this issue of Readout mentioned, assessing MPs in environments for its quan-

tity, migration and hazard requires statistical analysis of a massive amount MPs. Automated high throughput analysis is absolutely necessary, and a critical research goal. While research groups, with collaboration with HORIBA, are developing SOPs to become the template of automated analysis, a few elements are already identified as necessary.

MPs are often presented for analysis arrayed in a petri dish or retained on a filter. The size of a petri dish or a filter is much bigger than MPs, and navigation requires the stage travel a long distance while stopping at precise positions. A motorized stage with precision control makes navigation easier and more precise, making the experiment more efficient.

Another advantage of a motorized stage is software control and programmed movements. Coupling this ability to the microscopy functionalities of the XploRA PLUS, HORIBA developed an application module called ParticleFinder (PF)^[14] on the LS6 platform. PF acquires a microgram, and analyzes the counts, sizes, shapes, and locations of MPs. PF then moves the stage to each of the MP’s location, and acquires a Raman spectrum. The final results include total counts of all MPs, statistics of sizes and shapes, location and Raman spectrum of each MP, and spectral classifications.

As mentioned repeatedly, MPs are highly complex and heterogeneity targets for analysis. Data processing and analysis are proportionally complex^[15] requiring sophisticated software. LS6 offers extensive functionalities for data processing (e.g. baseline correction, smoothing, substrate spectrum subtraction, etc.), data analysis (e.g. multivariate analysis, library search, etc.) and visualization (e.g. image rendering) both developed in house and working with business collaborators: Bio-Rad Laboratories, Inc. to incorporate KnowItAll[®] library search, and Eigenvector Research Inc. for multivariate analysis (MVA).

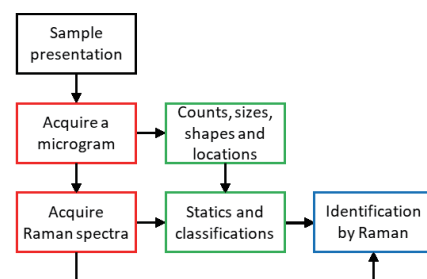

Figure 4 Workflow diagram of PF operation followed by identification by Raman library search. Red boxes highlights data acquisition steps in PF, green results generated in PF, and blue results coupled with library search

Table 2 Summary of HORIBA technologies useful for MPs analysis

Raman spectroscopy	Fluorescence spectroscopy	Particle size analysis	EDXRF [†] spectroscopy
Chemical identification & differentiation of: <ul style="list-style-type: none"> • Polymers • Additives • Dyes/Pigments • Natural particles 	<ul style="list-style-type: none"> • Probe effect of MPs on DOM* • Determine concentration of NPs • Quantify MPs for toxicity studies • Measure DOM in control studies 	<ul style="list-style-type: none"> • Measure particle size distribution of possible MPs • ViewSizer - Potential for nanoparticle tracking analysis for NP's 	<ul style="list-style-type: none"> • Analyze metals accumulated on MPs^[16]

* DOM stands for dissolved organic matter

† EDXRF stands for energy dispersive x-ray fluorescence

HORIBA technologies for MPs analysis

The complexity and heterogeneity of MP analysis requires, as demonstrated in the collaboration work with NOAA and NIST above, multimodal imaging and multi-technology approaches. It has, therefore, become a natural focus of interest how to combine, correlate and compare data and results from multiple sources. For now, we are still tackling data from one technology at a time. However, we are preparing for next steps, investigating future development possibilities such as data fusion, correlated microscopy and machine learning.

Conclusion

Microplastic (MP) is a mega trend that is growing even bigger presently. HORIBA is collaborating with KOLs of the field to determine (and influence) the market demand (and trend), and staying relevant to this newly emerging field. We have made an impression as ‘the’ Raman company for researchers who will provide guidelines to MPs regulations. The scientific and business opportunities are abundant, and we are making good progress.

* This content is based on our investigation at the year of issue unless otherwise stated.

References

- [1] Production, use, and fate of all plastics ever made, Roland Geyer, Jenna R. Jambeck, and Kara Lavender Law, *Science Advances*, 19 Jul 2017, Vol. 3, No. 7, e1700782, DOI: 10.1126/sciadv.1700782
- [2] Toxicological considerations of nano-sized plastics, Phoebe A. Stapleton, *Environmental Science*, 22 October 2019, Vol. 6, No. 5, 367-378. DOI: 10.3934/environsci.2019.5.367
- [3] A Comparison Of multiple Techniques, FT-IR, Py-GC-MS, and Raman for Polymer Identification in Plastic Marine Debris; Eunah Lee, Ashok Deshpande, Jennifer Lynch, Kayla Brignac, Melissa Jung, Nigel Lascelles, Dante Freeman, Davielle Drayton, Bridget O'Donnell, 13-18 October 2019, SciX 2019 final program, 58, <https://www.scixconference.org/resources/Documents/SciX2019FinalProgramWeb.pdf>
- [4] Increasing the Accessibility for Characterizing Microplastics: Introducing New Application-based and Spectral Libraries of Plastic Particles (SLoPP & SloPP-e); Bridget O'Donnell, Keenan Munno, Hannah De Frond, Chelsea Rochman, 13-18 October 2019, SciX 2019 final program, 62, <https://www.scixconference.org/resources/Documents/SciX2019FinalProgramWeb.pdf>
- [5] Rochman Lab, Freshwater and Marine Ecology, Ecotoxicology, Environmental Chemistry, Conservation, <https://rochmanlab.com/>
- [6] Microplastic Spectral Libraries: SLoPP and SLoPP-E Raman Spectral Libraries for Microplastics Research, <https://rochmanlab.com/slopp-and-slopp-e-raman-spectral-libraries-for-microplastics-research/>
- [7] Reproduction of Figure S1.C of Supporting Information of Marine Debris Polymers on Main Hawaiian Island Beaches, Sea Surface, and Seafloor, Kayla C. Brignac, Melissa R. Jung, Cheryl King, Sarah-Jeanne Royer, Lauren Blickley, Megan R. Lamson, James T. Potemra, and Jennifer M. Lynch, *Environmental Science & Technology*, 9 October 2019, Vol. 53, No. 21, 12218-12226, DOI: 10.1021/acs.est.9b03561
- [8] The Biochemical and Exposure Science Group of NIST, <https://www.nist.gov/mml/csd/biochemical-and-exposure-science-group>
- [9] Northeast Fisheries Science Center at NOAA, <https://nefsc.noaa.gov/>
- [10] Research interests of Southern California Coastal Water Research Project for Microplastics as a Part of Trash Pollution, <https://www.sccwrp.org/about/research-areas/additional-research-areas/trash-pollution/>
- [11] Details and specifications of BallProbe® by MarqMetrix for touch and immersed Raman measurements, <https://www.marqmetrix.com/products/ballprobes/>
- [12] An overview of chemical additives present in plastics: Migration, release, fate and environmental impact during their use, disposal and recycling, John N. Hahladakis, Costas A. Velis, Roland Weber, Eleni Iacovidou, Phil Purnell, *Journal of Hazardous Materials*, 15 February 2018, Vol. 344, 179-199, DOI: 10.1016/j.jhazmat.2017.10.014
- [13] Application of a Hybrid Fusion Classification Process for Identification of Microplastics Based on FT-IR Spectroscopy, Beauty K. Chabuka, John H. Kalivas, *Applied Spectroscopy (in printing)*
- [14] Details and specifications of ParticleFinder application module on LabSpec 6 Spectroscopy Suite platform, https://www.horiba.com/en_en/products/detail/action/show/Product/particle-finder-1657/
- [15] Review of Microplastic Data Processing and Interpretation Techniques with Future Outlook, Win Cowger, Andrew Gray, Silke H. Christiansen, Hannah DeFrond, Ashok Deshpande, Ludovic Hemabessiere, Eunah Lee, Leonid Mill, Keenan Munno, Barbara E. Obmann, Marco Pittroff, Chelsea Rochman, George Sarau, Shannon Tarby, Sebastian Primpke, *Applied Spectroscopy (in printing)*
- [16] Long-Term Sorption of Metals Is Similar among Plastic Types: Implications for Plastic Debris in Aquatic Environments, Chelsea M. Rochman, Brian T. Hentschel, Swee J. The, 15 January 2014, *PLoS ONE*, Vol. 9, No. 1, e85433, DOI: 10.1371/journal.pone.0085433



Eunah LEE, Ph.D.

Raman Projects Manager
HORIBA Instruments Incorporated (HII)



Bridget O'DONNELL, Ph.D.

Manager of Raman Applications
HORIBA Instruments Incorporated (HII)



Andrew WHITLEY, Ph.D.

Vice President of Sales and Business Development
Global Director of Business Development
HORIBA Instruments Incorporated (HII)

A Focus on HORIBA European Network Activity around Microplastics

Florian FORMANEK

Current research on microplastics, ranging from discovering or confirming their presence in various environments, to quantifying their induced pollution in food matrices, to understanding their impact on wildlife, ecosystems and even human health has become a hot topic worldwide. Europe has always been attentive to environmental issues and prompt to sponsor coordinated programs at the academic level, but also to regulate the different industries whose activities may generate microplastics. This featured article will detail a few initiatives from HORIBA Scientific in Europe to contribute to the harmonization of analytical methods, including sample collection and preparation, as well as to the development and validation of standard reference samples in the field of microplastics research.

Introduction

Microplastics (MPs) are present in every environmental compartment, including in the remotest places on earth, and have gained recent interest as a major environmental pollutant. In 2015, the European Union (EU) produced 25 million tons of plastic waste, with 60% still originating from packaging, representing an average of 31 kg per person per year. Worth noting is the fact that the majority of the MPs released in the ocean originate from synthetic textiles, tire dust or city dust.

“Plastic” is not a well-defined term, but rather encompasses a set of synthetic polymeric materials having a wide range of high molecular weight, and whose particle dimensions span 6 orders of magnitude in size, from the nanometer up to 5 mm. MPs present a large variety of chemical compositions: (co)polymers, residual monomers, chemical additives, catalysts or fillers, and can even be contaminated by non-intentionally added substances. While naturally occurring polymers exist, such as rubber or cotton, plastic pollution mostly originates from a few synthetic polymeric families like Polystyrene (PS), polyethylene (PE), polypropylene (PP), polyvinylchloride (PVC) or polyethylene terephthalate (PET).

This diversity gave rise to a search of a variety of methodologies to answer the burning questions in MPs research and to support plastic pollution monitoring and mitigation policies under consideration by state and non-state actors. The existence of various definitions for different

regulatory sectors and regions also complicates understanding and implementation of legislation.

Moreover, no validated and harmonized standard methods are currently available for the analysis of MPs and many analytical protocols and techniques are used. There is still no consensus on the reporting format, in terms of number of particles, mass of size fractions, and an absence of certified reference materials to investigate analytical proficiencies.

Those points were highlighted during the Global Summit on Regulatory Science (GSRs) 2019 Nanotechnology and Nanoplastics which took place in Ispra (Italy) in September 2019,^[1] organized by the European Commission Joint Research Center (JRC), whose mission is to provide scientific advice and support to the European Union policy.

All this explains why open interlaboratory studies were recently set up in order to address those shortcomings.

Evidence of microplastics in food

HORIBA Scientific is proud to count world-leading research teams among his customers of Raman spectrometers. Their affiliations reveal the wide range of fields where Raman microscopy is used to study MPs: environment institutes, health and food safety authorities, oceanology and hydrology departments, marine biology agencies, ecotoxicology laboratories, but also water treat-

ment and distribution entities or bottled water companies.

Clearly, the most pressing question on the scientific community agenda is whether or not MPs pose a threat to human health, especially through seafood consumption. To that extend, the European Food Safety Authority (EFSA) Panel for Contaminants in the Food Chain (CONTAM) was asked, following a request from the German Federal Institute for Risk Assessment (BfR), to deliver a statement on the presence of MP (but also nanoplastics) in food, with particular focus on seafood.^[2]

This bibliographic review confirmed that MPs can be ingested by many marine invertebrates and have the potential to be transferred between trophic levels, as illustrated in Figure 1. Indeed, the presence of plastic debris, indicated as anthropogenic debris, in the gastrointestinal tract of fished on sale for human consumption was sampled from markets in several countries.

Following on this statement, a team of researchers from IFREMER (French Research Institute for Exploitation of the Sea) and ANSES (French Agency for Food, Environmental and Occupational Health & Safety) has developed a protocol to extract and characterize MPs from seafood tissues, which should be implemented to assure the relevance and comparison of further studies or assess seafood product quality, notably to follow recom-

mendation from the OSPAR Convention for the Protection of the Marine Environment of the North-East Atlantic, ratified by 15 EU countries in relation with the Marine Strategy Framework Directive.

Plastic integrity and composition was evaluated through microscopic inspection and the use of HORIBA LabRAM Raman spectrometer, before and after digestion by KOH 10% solution with 24 h incubation at 60°C.^[3]

Again, related to fish meal pollution, HORIBA Scientific recently participated in a study which demonstrated that cultured (farmed) organisms could be exposed to high levels of MPs via contaminated fish/shellfish used in fish meal production by the aquaculture industry.^[4] The most abundant isolated plastic polymer was PE (63.0%) followed by PP (27.8%) and PET (8.8%), while the average size of the particles was found to be 855 µm.

Another publication coauthored by HORIBA Scientific in Scientific Reports^[5] made the headlines when it revealed the presence of MPs even in commercial sea and lake salts originating from 8 different countries (Figure 2). This study also raised concerns over the possible transfer of other contaminants associated with MPs into salt, such as pigment fragments, some of them being toxic.

Another milestone article investigated the presence of

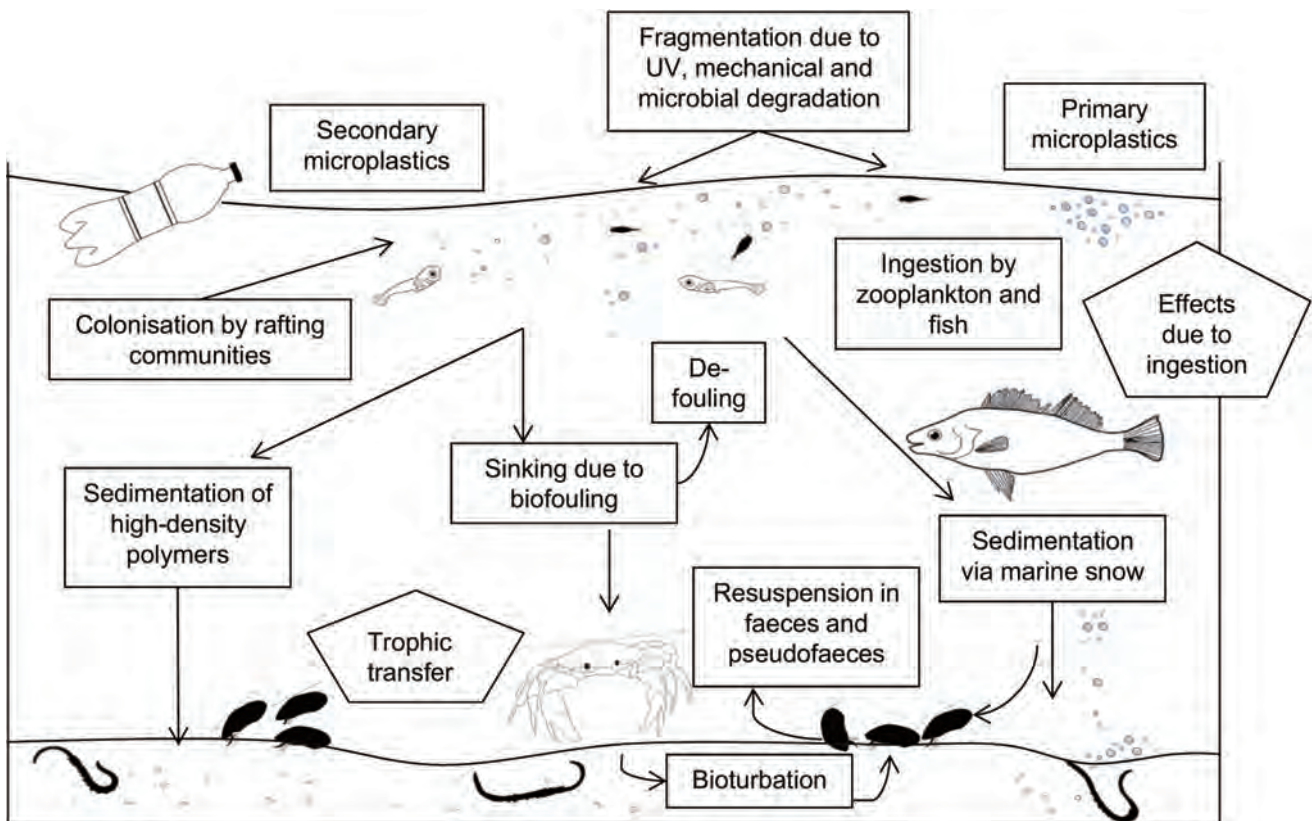

Figure 1 Potential pathways for the transport of microplastics and their biological interactions.^[1]

MPs in mineral waters from different bottle types.^[6] Led by scientists from the Bavarian Health and Food Safety Authority (LGL) in Germany, the team focused on small particles (below 5 µm) posing higher toxicological risks as they have the potential to translocate into body tissues and are more likely to penetrate deeply into organs. Using

a HORIBA XploRA PLUS system to locate and identify particles down to a size of 1 µm on specially prepared aluminum coated polycarbonatemembrane filters, evidence of higher amounts of MPs in reusable bottles (PET as well as glass) was found compared to single use bottles.

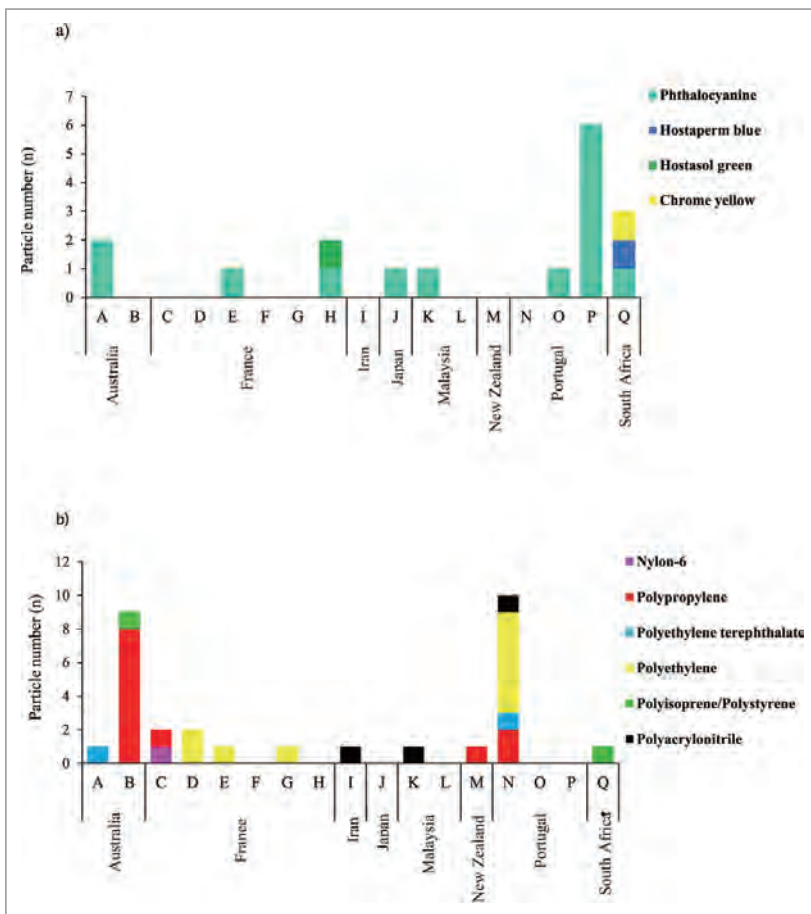
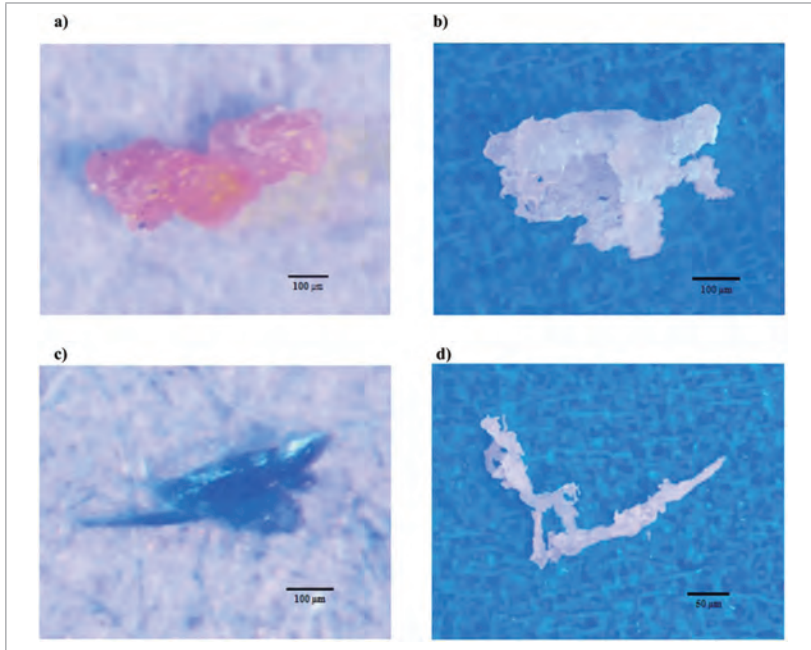

Figure 2 Top: Microscopic images of some of the extracted particles. (a) polyisoprene/polystyrene, (b) polyethylene, and (c) pigment (phthalocyanine) fragment. Image (d) is a nylon-6 filament. Bottom: Stacked bar chart of the number of (a) plastic polymer and (b) pigment particles isolated from different salt brands.^[5]

Open interlaboratory studies

A recent meeting hosted by the Group of Chief Scientific Advisors of the European Commission,^[7] supported by the evidence review of the SAPEA Consortium (Science Advice for Policy by European Academies),^[8] concluded on the lack of harmonized methodologies in order to generate standardized data. On this basis, several organizations initiated collaborative programs with the aim of validating internal laboratories quality assessment and competence, supporting environmental data, providing data for national and international stakeholders or supporting accreditation.

One of the initiatives in which HORIBA took part was set up by the Vrije Universiteit Amsterdam (VUA), the Norwegian Institute for Water Research (NIVA) and the WEPAL (Wageningen Evaluating Programmes for Analytical Laboratories) organization based in the Netherlands and recognized by the Dutch Accreditation Council (RvA).

This international interlaboratory study on MPs, called QUASIMEME for “Quality Assurance of Information in Marine Environmental monitoring”, saw 34 laboratories participating to analyze the test materials between May in August 2019, using several instrumental and quantification methods, with the objective of counting the particles and identifying their chemical family.

Test samples were prepared at NIVA, to enable the analysis by a broad variety of analytical methods and techniques: visual, hyperspectral imaging, Fourier transform Infrared Spectroscopy (FT-IR), Raman and Mass Spectrometry ; and consisted of 6 preproduction pellets, 5 tablets containing microplastics fragments (ob-

tained after filtration of PET, PVC and PS powder) of fibres and 1 blank tablet. The fibres were created by washing polyester blankets in a typical domestic washing machine. While the majority of the participating laboratories used ATR-FT-IR (Attenuated Total Reflection FT-IR) or μ -FT-IR, we employed Raman microscopy (Figure 3), which is favorable for small size particles, typically below 20 μm .

Table 1 shows an example of reported table by the participants for one of the tablet sample. Although some polymer misidentification occurred in some cases, the polymer type was correctly assigned for both larger preproduction pellets (2-4 mm) and particles or fibres added to the tablets (150-300 μm). However, the reported number of particles varied considerably (up to 78% standard deviation), and the standard deviations of the determination of the polymer type in the tablets varied from 29% (for PET) to 99% (for PS).

Overall, the results of this first round indicate that polymer identification and quantification of the number of plastics particles in a sample (especially in smaller size fractions) is not simple or straightforward. Yet, HORIBA's Applications Laboratory was able to demonstrate analytical results on par with recognized European facilities.

This round of the QUASIMEME study will be followed by exercises with increasing complexity and difficulty of samples, including MPs extracted from complex matrices (e.g. sediments and fishes). After several study rounds, the

analytical methodologies for MPs are expected to be better comparable and will be included in a routine proficiency testing scheme.

HORIBA Scientific also recently responded to a call to enter an exploratory study organized by the JRC, with support from the German Federal Institute for Materials Research and Testing (BAM).^[9] The aim of this proficiency test study on MPs in water in sediments is to help in the identification of possible method candidates for future validation and standardization.

In practice, reference samples employed to benchmark laboratories were developed and qualified beforehand. Those samples were sent to the different laboratories to be prepared on site through a reconstitution protocol, from vials containing a NaCl-carrier with embedded PET particles, a surfactant solution (triton X-100), and deionized water. Participants are to report the number of particles or mass of particles above 30 μm , the particles identified as PET, particles identified as plastic (including PET) and particles of any kind, with a report of the measurement uncertainty.

A workshop will take place during the summer of 2020 to discuss the results and conclusions once the participants report their findings.

Finally, HORIBA France is actively involved in a group of experts within the French Standardization Association (AFNOR) currently working on establishing a regulation

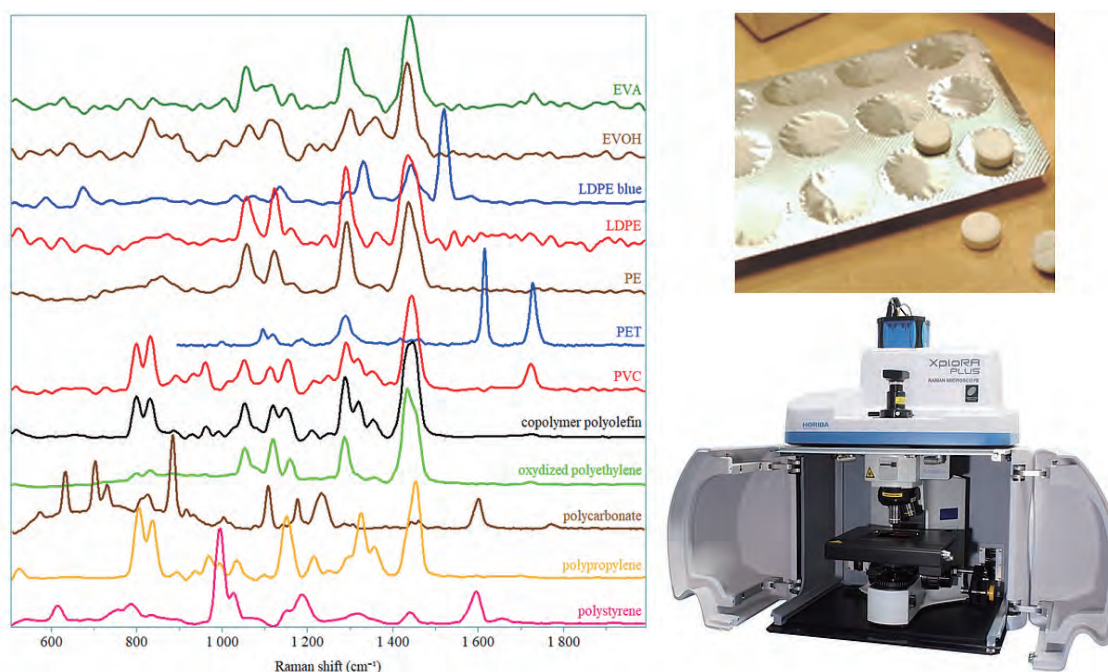

Figure 3 Left: Raman spectra recorded on different polymer families.
Top right: aluminum strip pellet containing 12 tablets sent to participants, that were to be dissolved in analytical grade water to control background contamination.
Bottom right: HORIBA Xplora PLUS Raman microscope with class I laser enclosure used for this study.

Table 1 Type and number of plastic particles reported for table in position no. 10 in the strip pellet shown in Figure 3, by all the participating laboratories of the QUASIMEME study.

Laboratory	acrylonitrile butadiene styrene	Black fiber	Blue fiber	Cellulose	Cellulose fiber black	Cellulose fiber white	Crystalline particles	Grey fiber	Grey piece	High density polyethylene	Low-density polyethylene	polymethylmethacrylate	Polyamide	polybutylmethacrylate	Polycarbonate	Polyester	Polyethylene	polyethylene terephthalate	Polypropylene	Polystyrene	Polytetrafluoroethylene	Polyurethane	Polyvinylchloride	red fiber	TiO2	Unknown	Total particles
H221																44											44
Q101				8														5	< 3	8			14				35
Q104					1	85												9	13			18					126
Q110																		3								4	7
Q114																		10								28	30
Q134										1								7	1	26			26				61
Q152																							34			3	37
Q153																										48	48
Q871																		7	2	37							46
Q968		2						1	1																		4
Q3175			3		6															10				2			21
Q3231															8					13						19	40
Q3239																											
Q3872																	8	11		33			21				73
Q3873	1										1					30		8	39				10				79
Q3876																				5							15
Q3877																											
Q3878																		31		22							53
Q3879																		5	5	6			17				33
Q3882																				11			30				41
Q3883															8					17			19				44
Q3884																				28			27				55
Q3885																		1		6			20				27
Q3887																		7	23				26				56
Q3888	1								8				1				10	6	51	2	1	10					90
Q3889						17		7																			24
Q3890												1						3		29			32				65
Q3891															30			6		12			14	3			65
Q3892																		3		2			11				16
Q3894																											
No. of reporting labs	2	1	1	1	1	2	1	1	1	2	1	1	1	1	1	3	2	15	6	20	1	1	16	1	1	5	27
Average	1	2	3	8	1	46	17	1	1	7	4.5	1	1	1	30	20	19	5.5	4.4	17.1	2	1	20.2	2	3	18.5	42.0
Standard deviation						56					4.9				21	16	4.0	3.9	13.3			9.25				20.9	24.3

on the analysis of MPs in drinking water, through spectroscopic techniques (µFT-IR and Raman). This group, part of the T91M “Organic micropollutants” Commission, gathers various governmental, academic and industry organizations, including the Standardization Bureau for Plastics and Plastics Engineering (BNPP), with the objective of drawing up a new norm for the first half of 2021. This work was presented at the last ISO (International Organization for Standardization) meeting held by the Technical Committee TC 147 on Water Quality in Tokyo, with the purpose of reaching a global consensus in the near future.

Challenge and perspectives

With the improvement of the robustness of analytical techniques, researchers working in the field of MPs will more easily be able to trust their results and compare their studies.

The most pressing question to answer, as little is known at this point, concerns the toxicity of MPs on human health. In particular, an important aspect revolves on the fact that MPs both absorb and give off toxic chemicals and harmful pollutants, which may build up over time and stay in the environment.

There is also a clear lack of knowledge on nanoplastics (particles smaller than 0.1 µm), which may represent a greater risk to the environment and health. However, their characterization is currently hindered by technical limitations and will require new instrumental developments.

To conclude, it is worth mentioning that the microplastics scientific community will gather at MICRO 2020^[10] in Arrecife (Spain), the major biannual international conference focusing on the fate and impacts of microplastics.

HORIBA Scientific will be present !

* This content is based on our investigation at the year of issue unless otherwise stated.

References

- [1] <https://ec.europa.eu/jrc/en/event/conference/gsr19-global-summit-regulatory-science-2019-nanotechnology-and-nanoplastics>
- [2] Presence of microplastics and nanoplastics in food, with particular focus on seafood. *EFSA Journal*, **14**(6), 4501 (2016).
- [3] Alexandre Dehaut, Anne-Laure Cassone, Laura Frère, Ludovic Hermabessiere, Charlotte Himber, Emmanuel Rinnert, Gilles Rivière, Christophe Lambert, Philippe Soudant, Arnaud Huvet, Guillaume Duflos, Ika Paul-Pont. Microplastics in seafood: Benchmark protocol for their extraction and characterization. *Environmental Pollution*, **215**, 223-233 (2016).
- [4] Samaneh Karbalaee, Abolfazl Golieskardi, Dorothy Uning Watt, Mathieu Boiret, Parichehr Hanachi, Tony R. Walker Ali Karami. Analysis and inorganic composition of microplastics in commercial Malaysian fish meals. *Marine Pollution Bulletin*, **150**, 110687 (2020).
- [5] Ali Karami, Abolfazl Golieskardi, Cheng Keong Choo, Vincent Larat, Tamara S. Galloway & Babak Salamatina. The presence of microplastics in commercial salts from different countries. *Scientific Reports*, **7**, 46173 (2017).
- [6] Barbara E. Oßmann, George Sarau, Heinrich Holtmannspötter, Monika Pischetsrieder, Silke H. Christiansen, Wilhelm Dicke. Small-sized microplastics and pigmented particles in bottled mineral water. *Water Research*, **141**, 307-316 (2018).
- [7] Environmental and Health Risks of Microplastic Pollution. doi:10.2777/54199
- [8] SAPEA, Science Advice for Policy by European Academies. (2019). A Scientific Perspective on Microplastics in Nature and Society. <https://doi.org/10.26356/microplastics>
- [9] <https://ec.europa.eu/jrc/en/science-update/call-laboratories-participate-proficiency-tests-microplastics-drinking-water-and-sediments>
- [10] <https://micro2020.sciencesconf.org/>



Florian FORMANEK, Ph.D.

Head of Applications
HORIBA Scientific, France

Microplastics Related Activities in Our HORIBA Group, Japan

NUMATA Tomoko
YAMAUCHI Susumu

In recent years, plastics pollution has become a widely discussed international problem. Drifting into the ocean from the urban areas, plastics gradually miniaturize into small particles called microplastics, that affect ecosystem in many various ways. HORIBA Group engineers and scientists in Japan and worldwide, are working to establish the measurement techniques for microplastics analysis. In this paper, we will introduce our HORIBA Group's efforts in Japan, in response to the microplastics analysis needs, including application examples.

Introduction

In the past several decades, plastics were widely used due to their many convenient benefits, but in recent years, the plastic pollution has become a widely discussed international problem. Drifting into the ocean from the urban areas, plastics gradually miniaturize into small particles that affect ecosystems in many various ways. These plastic particles are called Microplastics (MPs) when they get smaller than 5 mm.

The G20 summit held in Osaka in June 2019, resulted in the “Osaka Blue Ocean Vision” declaration which aims to stop any additional pollution being introduced into the ocean by 2050. To achieve this goal, the Japanese “Ministry of the Environment and Ministry of Economy, Trade and Industry” has introduced several programs: (1) reduction and replacement with alternative materials, (2) recycling and resource circulation, (3) countermeasures against sea pollution, and (4) introduction of various national movements for dissemination and awareness activities.

Analytical instruments for MPs characterization

MPs size range and evaluation parameters depend on analysis purposes and survey targets: sea, river, lake, pond, sewage treated water or factory drainage. Measurement conditions and the applied instruments are shown in Table 1. MPs research of sea water is focused on 300 µm to 5 mm, while for the sewage treatment and drinking water it is focused on the size smaller than 300 µm. In the life science field research is focused on particles smaller than 10 µm, because of their impact on the ecosystem.

Recently it is becoming common to consider to use several techniques for MPs characterization to provide a complete picture of information.

Table 1 Survey target, condition and applied instruments for MPs identification

Survey target	MPs size	Preparation	Analytical instruments
Sea, River, Lake and Pond	300 µm ~ 5 mm	Picking up	FT-IR, Raman pyrolysis-GCMS
Sewage water, Factory drainage	10 µm ~ 300 µm	Primary filtration	FT-IR Microscope Raman Microscope
Clean water, Drinking water	< 10 µm	Oxidization	Raman Microscope
Food Cosmetic		Gravity separation	
Impact on Ecosystem (biocells)		Secondary filtration	

MPs measurement's issues

In the case of MPs characterization, analytical methods and measurement parameters depend on the evaluation target: particle size, composition, mass, surface area, and identification of plastic types and additional hazardous substances. Furthermore, the method of collecting the sample, the method of removing contaminants and pre-treatment differ depending on the target sample. The smaller the MPs particle size, the more difficult characterization becomes. Many of above mentioned methods are currently performed using each researcher's personal knowledge. This now needs to be considered towards a standardization process for better reproducibility of research and for reliable data comparison moving forward. Currently it also requires a lot of time and effort to

perform multiple measurements, because most of sample treatments are done manually. Therefore, automation and semi-automation for sample treatment should be prioritized to reduce significantly the time and labor required for MPs analysis.

Activities in Japan

As a reaction to the MPs pollution problem, many seminars and symposiums have been held in Japan’s industry and academia societies. In various seminars, on the theme “Particle size analysis and Raman spectroscopy for MPs”, HORIBA has introduced measurement examples using HORIBA products. Several instruments like: the Laser Diffraction Analyzer (LA-960V2), the Dynamic Laser Scattering (SZ-100V2) and the Nanoparticle Tracking Analyzer (ViewSizer™ 3000), are used to characterize particle size and distribution, particle number and concentration, zeta potential and aggregation conditions. Our capability to cover a wide size range of samples (mm ~ μm ~ nm) was introduced.

In addition, we have demonstrated that our Raman Microscopes (XploRA PLUS and LabRAM Evolution) equipped with the particle analysis function (Particle-Finder) enables users to associate chemical information with particle size, shape, number and compositions using automated image analysis functions for the Component

analysis was performed using Fourier detection and positioning of small particles.

A list of events and presentation titles are summarized in Table 2 and HORIBA product pictures, used for this study are shown in Figure 1

MPs mock sample analysis

The presence of MPs in our environment other than environmental water, such as our ocean and rivers, has also been reported, for example in air, drinking water and food.^[2] In this article, we will introduce two analysis examples: mock MPs samples from environmental water and MPs obtained from the atmosphere.

A MPs mock sample was prepared by pulverizing a polypropylene (PP), polyurethane (PU), polymethylmethacrylate (PMMA), and polyethylene terephthalate (PET) mixture.

Component analysis was performed using Fourier Transform Infrared (FT-IR) microscopy. Particle size distribution and image observation were performed using a laser diffraction/scattering particle size analyzer with an optional built in Imaging Unit.^[3] The respective measurement systems will be described below.

Table 2 List of events and presentation title

Event name	Date	Title	Organizer
JASIS conference	2019/9/6	Microplastic measurement and environmental impact	Japan Society for Environmental Chemistry (JSE) Japan Analytical Instruments Manufacturers’ Association (JAIMA)
JETA seminar	2019/11/28	Measurement of microplastics in environmental water	Japan Environmental Technology Association (JETA)
AIST symposium	2019/12/2	Measurement and evaluation of microplastics	National Institute of Advanced Industrial Science and Technology (AIST)

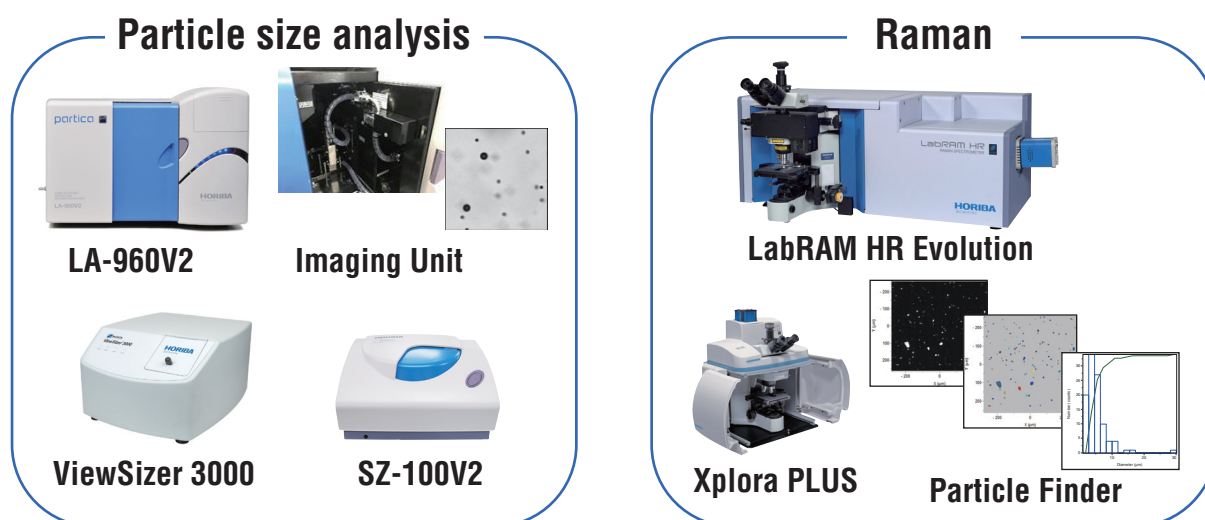

Figure 1 HORIBA product's pictures, used for this study

histogram of particle size distribution can be calculated from image particle analysis results.

After collecting water from the ocean or river, and pre-treatment for MPs separation, the measurement of particles number and a component analysis by FT-IR microscopy is widely adopted for the MPs analysis. The MPs mock samples used in this study were prepared by pulverizing a PP, PU, PMMA, and PET mixture. A photograph of the sample inside the plastic case is shown in Figure 3(a). This sample was dispersed on a metal substrate and infrared reflection-absorption imaging was performed by a FT-IR microscope. The spectrum obtained from each measurement point was subjected to principal component analysis to obtain a distribution chart of PP, PU, PMMA and PET. As shown in the Figure 3(b), (c), all the particles in the observed image could be identified.

The laser diffraction scattering particle size analyzer used for the same mock sample found the particle size distribution to be within a 10 μm to 2 mm range. As shown in Figure 3(d), it can be seen that the results can be obtained with high particle size resolution.

Inserted in part of Figure 3(d) shows images of particles with different shapes. Using the Imaging Unit it is possible to observe actual particles simultaneously with the particle size distribution.

Measurement of Airborne Microplastics by Raman Microscopy

Currently several researchers have reported Airborne microplastics (AMPs) found in the atmosphere of urban areas, high altitude mountains and the arctic circle.^[4] These facts suggest that AMPs contamination is widely spread due to atmospheric circulation. In addition, AMPs smaller than 10 μm may have a bad influence not only on the environment but on the human health due to inhalation.^[5]

In this study, we evaluated AMPs collected in the free troposphere (ca. 2000-11000 m a.s.l.) by researchers in Waseda University. AMPs collection was performed at night on the top of Mt Fuji at an altitude of 3776 m. A cyclone type High Volume Air Sampler (SIBATA SCIENTIFIC TECHNOLOGY LTD.) was used to collect PM2.5 particles on a Teflon filter. Chemical composition analysis was performed after removing natural organic or inorganic particles. In general, a FT-IR microscope is used to analyze larger microplastics, but because the expected estimated size of AMPs is smaller than 10 μm , the FT-IR microscope spatial resolution would be not sufficient. Therefore we decided to use Raman microscopy which has a much higher, up to sub-micron scale, spatial

resolution.

Raman spectroscopy can perform composition analysis and crystallinity evaluation from inelastic light scattered (Raman scattering) on a laser irradiated sample. By combination of a microscope and motorized sample stage, sub-micron spatial resolution Raman chemical imaging is achievable.

In order to perform Raman measurements, we transferred AMPs to an Almina filter and carried out mapping measurement in 4 areas, 1 mm² each, followed by the imaging of CH stretching mode intensities. This image illustrates distribution of the existing organic compounds in the AMPs. 30 pieces of AMPs were detected in the 4 mapping areas. By conducting point measurement of detected AMPs with longer acquisition times, a total of 15 different polymer species there identified. Figure 4 shows the optical image of part of the detected AMPs on the Almina filter using a X100 objective lens. Figure 5 shows the

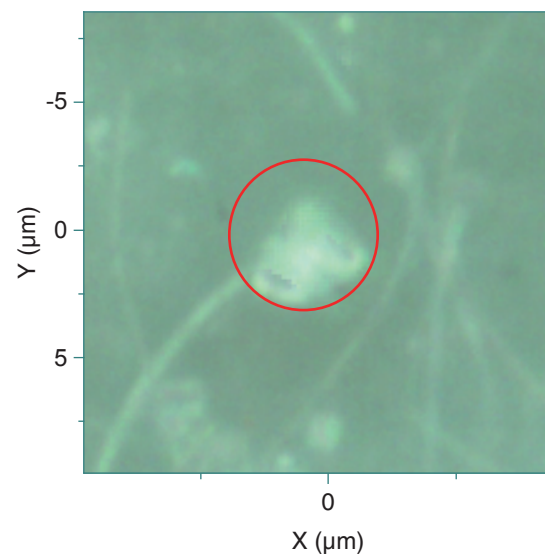

Figure 4 Optical image of detected AMPs

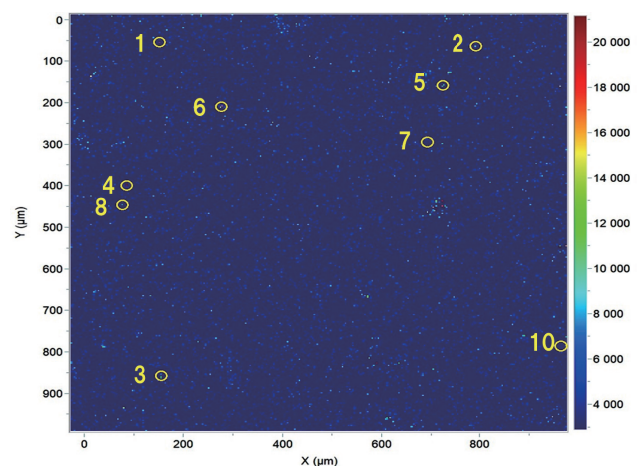

Figure 5 Image of CH stretching mode intensity

Table 3 AMPs size and identified species chemical names

target	Size/ μm	identified compound by Library search
1	8 (diameter)	Polystyrene (PS)
2	6 (Maj axis), 4 (Min axis)	Unidentified polymer + TiO_2
3	3 (diameter)	Polyester
4	4 (diameter)	Polypropylene (PP)
5	6 (Maj axis), 4 (Min axis)	Polyurethane (PU)
6	12 (Maj axis), 3 (Min axis)	Polyethylene (PE)
7	1.4 (diameter)	Poly-3-Hydroxyl Butyl acid
8	2 (diameter)	Polyolefin
9	28 (Maj axis), 2 (Min axis)	Polytetrafluoro ethylene (PTFE)
10	ND	Polyolefin

image of CH stretching mode intensities in one of the mapped areas. In Table 3 the AMPs size and identified species chemical names are summarized. Most of the AMPs were smaller than $10 \mu\text{m}$. 37% of detected particles were made from Polypropylene material, followed by biodegradable plastics such as Polyhydroxybutyric acid.

The AMPs number concentration in the atmosphere, calculated in this study, was found to be $4.47 \text{ particles/m}^3$. These results show that Raman microscopy is suitable for the qualitative analysis of MPs composition for particles smaller than $10 \mu\text{m}$.

Acknowledgments

We would like to thank Mr. Takemoto of Toray Research Center, Inc., for providing us application data for the MPs mock sample analysis. We would like also to thank Prof. Hiroshi Okochi of Waseda University, Faculty of Science and Engineering, for providing samples and guidance for AMPs analysis.

* This content is based on our investigation at the year of issue unless otherwise stated.

References

- [1] Yutaka Kamed, Abstract for 28th Technical Seminar, Japan Environmental Technology Association (JETA), 2019 (in Japanese)
- [2] Laura M. Hernandez, Elvis Genbo Xu, Hans C. E. Larsson, Rui Tahara, Vimal B. Maisuria, Nathalie Tufenkji, Plastic Teabags Release Billions of Microparticles and Nanoparticles into Tea, *Environ. Sci. Technol.*, 53, 21, 12300-12310(2019)
- [3] Toray Research Center, Inc., No.0386 Microplastics 's examination of analytical method and trend survey of related techniques, https://es2.toray.co.jp/news/trc/news_rd01.nsf/0/DB586848DFC3BE DF492584B20024AA1B?open, (reference date 20200424) (In Japanese)
- [4] Hiroshi Okochi et al, Tokyo University of Science Research Institute for Science & Technology Atmospheric Science Research Division Proceedings of 4th Research Result Report Meeting, (2020)
- [5] Hiroshi Okochi, Incorporated nonprofit organization Mount Fuji Research Station Proceedings of 13rd Research Result Report Meeting, (2020)



NUMATA Tomoko

Manager
Analytical Technology Department
HORIBA TECHNO SERVICE CO., LTD.



YAMAUCHI Susumu

General Manager
Industry-Academia-Government Relations Office
HORIBA Advanced Techno, Co., Ltd.

Product Introduction

X-ray Fluorescence Sulfur/Chlorine-in-Oil-Analyzer MESA-7220V2

UEDA Hideo

Michael POHL

The regulations for sulfur concentration in the automotive fuels have now started going down to 10 mg/kg around the world. In the refineries, it is necessary to control the costs for de-sulfurizing the incoming crude oil. In order to do this, it is required to know the incoming sulfur concentration as well as the clean crude oil being distilled in the refinery. The logical technology to employ is Energy Dispersive X-ray Fluorescence (EDXRF) spectrometry as it can easily measure the mass % levels of sulfur in crude oil as well as the ppm (mg/kg) levels of sulfur in the final product. The HORIBA MESA-7220V2 has been developed in order to meet these two concentration ranges and everything in between.

Key words

ASTM D7220, Monochromatic Energy Dispersive X-ray Fluorescence Spectrometry, Singly curved Highly Oriented Pyrolytic Graphite, Lower back ground, Limit of Detection less than 1 mg/kg

Introduction

Sulfur is naturally occurring in all crude oil samples and thus appears in refined fuel samples. The pollution effect of the sulfur combustion products as well as the poisoning of catalytic systems make continued reduction in sulfur concentrations essential. The current level in Tier 3 gasoline is set at the 10 mg/kg level and is expected to be reduced in the future.

In the case of diesel fuel, the limit for low sulfur diesel was set at 500 mg/kg in the mid 1990's and ultra-low sulfur diesel at 15 mg/kg in 2006. These regulations were originally specified for on-road vehicles; but have now been expanded to include construction equipment, trains, and home heating oil. There is even a movement afoot to extend it to the maritime industry in the future. These sorts of requirements were exactly the ones which were used in the MESA-7220 design.

If the requirement is restricted to the sulfur in crude oil, then ASTM D4294 is an excellent, cost effective solution. With a measurement range of 17 mg/kg to 4.6 mass %, the requirements for crude oil are easily met. In order to meet these needs over the years, HORIBA has developed the SLFA-60, SLFA-6100, and the SLFA-6800.^[1] These units measure samples inside enforcement vans, on board ships and in independent test labs.

As the sulfur concentrations in fuels have gone lower and lower, the D4294 technology did not have the required sensitivity. As a result, some modifications to the basic design were required. The approach taken was to reduce the noise level so that the small sulfur peak could be more easily detected and quantified. This was accomplished with the use of special optics to filter out the undesirable X-rays from the detector. The result of this work was the MESA-7220 and ASTM Method D7220.

ASTM D7220-12

The new revision of the method D7220 was approved in 2012 just in time for use with some of the newer fuel requirements. The method is written around a series of petroleum types. These include gasoline, home heating oil, jetfuel, and others. The scope of the method is 3 mg/kg up to 942 mg/kg. The method is based upon the EDXRF method. This method is based upon a number of new optical developments. As a part of the method, the source of the X-ray was specified to be an end window X-ray tube with Ag or Pd electrode. This beam then hits a Highly Oriented Pyrolytic Graphite (HOPG) crystal which works as an X-ray diffraction grating. This Bragg Optic is designed to produce mono-chromatic Ag or Pd radiation which is focused on the typical sample cell containing the material of interest.

The resulting X-rays coming off the sample, primarily

sulfur fluoresced X-rays then get into the detector. The X-ray detector is typically a Silicon Drift Detector (SDD), but it must have a resolution value not to exceed 175 eV at 5.9 keV and 10 kcps. Using a detector meeting these requirements has proven essential to separate the fluorescence peak of chlorine from that of the sulfur. These elements both appear in petroleum type samples and this separation is required to avoid chlorine from interfering with the sulfur measurement.

In order to avoid the effect of low levels of Ar present in atmospheric air, a vacuum of ≤ 4.0 kPa must be applied to the X-ray optical system. In addition, the instrument must include signal conditioning and data handling electronics. These features permit the X-ray intensity counting and spectral analysis. It also allows for the subtraction of background X-rays, peak deconvolution, and calculation of overlap corrections. This results in the conversion of X-ray intensity into sulfur concentration.

X-ray Optics and Performance

The MESA-7220V2 has been developed as a mono-chromatic EDXRF instrument. It is equipped with an end window X-ray tube with an Ag anode. The X-ray is diffracted on a HOPG crystal which passes the Ag-L α radiation. This radiation strikes the sample cup and the emitted X-rays are directed into an SDD.

The HOPG crystal^[2] is prepared in a high temperature furnace also under high pressure. Layers of poly-imide film are laid down, and the heat and pressure is applied. The resulting graphite block is composed of highly oriented carbon layers. This material acts as a diffraction grating to be used as a monochromator for Ag-L α X-rays of 2.98 ± 0.02 keV as illustrated in Figure 1. This is then configured as a slightly curved crystal.

This curvature is required in order to make the X-ray

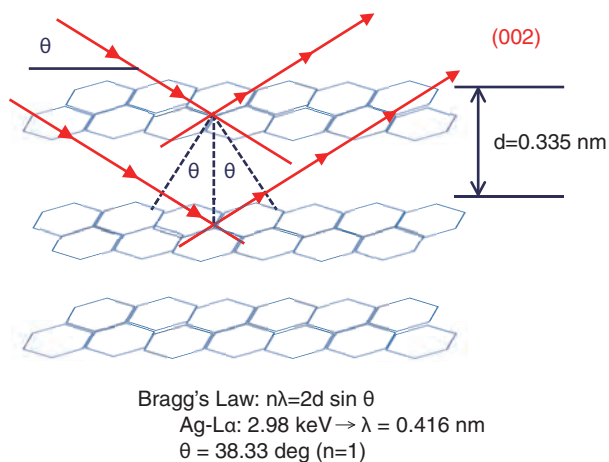

Figure 1 HOPG

beam converge. A singly curved HOPG crystal whose radius of curvature is equal to 2R creates a converging optic called a Rowland circle. This circle whose radius is equal to R is illustrated in Figure 2. The X-ray source, the center of the HOPG surface and the focal point on the sample all fall on the circumference of the Rowland circle.^[3] The result of the X-ray focusing of the beam prior to the sample cell is a line shaped beam.

The complete MESA-7220V2 optical system is shown in Figure 3. The X-ray beam from the Ag anode, the center of the HOPG surface, and bottom of the sample cell are all aligned on the circumference of the Rowland circle. The HOPG crystal can then be manually rotated to find the best angle to maximize the S-K α intensity. An example of the spectrum which is produced is shown in Figure 4. The Ag-L α and its second harmonic are diffracted from the HOPG crystal. The former is the characteristic X-ray anode of the X-ray tube and the latter is the continuous X-ray from the target.

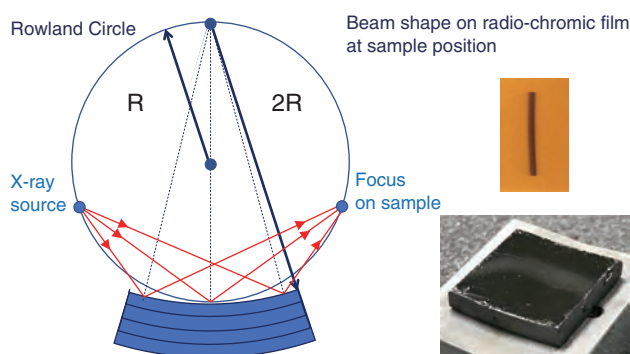

Figure 2 Singly curved HOPG

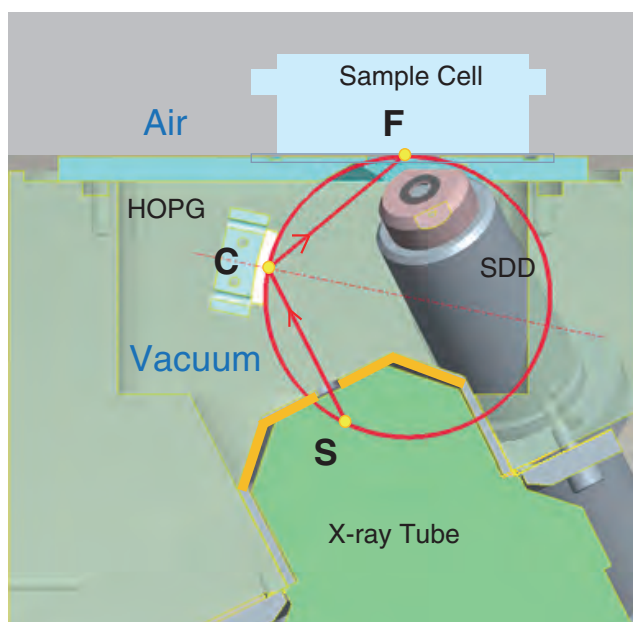

Figure 3 X-ray optics

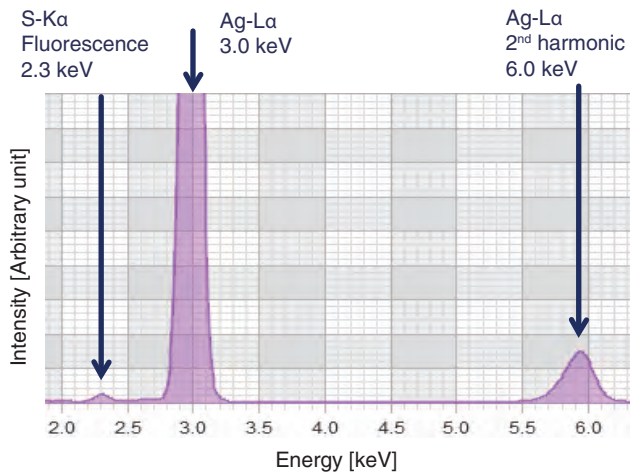

Figure 4 X-ray spectrum

The optics are receiving both the fluoresced X-ray and the scattered X-ray from the sample. Comparison of the spectra caused by continuous X-ray excitation versus monochromatic excitation is shown in Figure 5. Measurement of blank (sulfur-free) sample shows up the background of the sulfur measurement. It illustrates the 10 fold improvement of S-Kα intensity for blank mineral oil with the monochromatic beam. The data analysis yields a Limit of Detection (LOD) of 3.2 mg/kg for the continuous X-ray

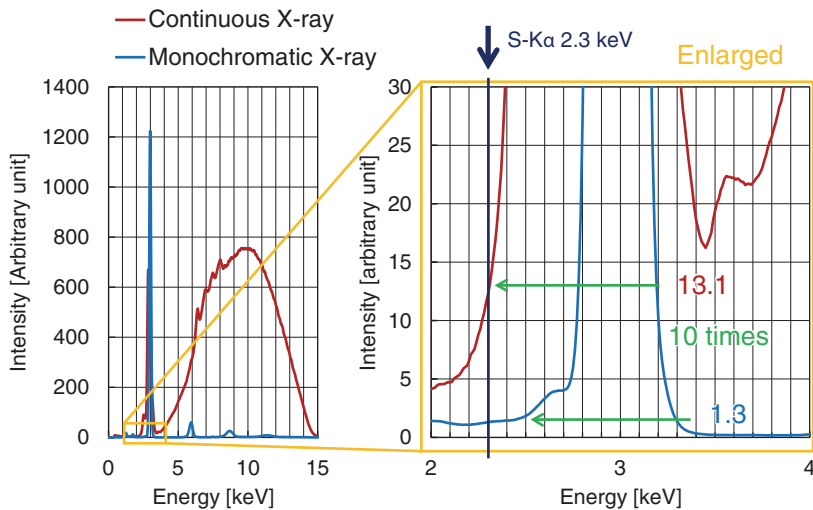

Figure 5 Lower back ground



Figure 6 MESA-7220V2 and the optional 8 positions turntable

beam and 0.5 mg/kg for the monochromatic beam. Thus the much better sensitivity of the mono-chromatic instrument is proved.

Features and Benefits

(1) Auto-Sampler

The turntable is an option which can automatically switch samples to speed up the analysis and reduce the operator involvement. The 8 position sampler is shown in Figure 6.

(2) Measurement Modes

The software offers four different modes of analysis. These include sulfur-only analysis, chlorine-only analysis, sulfur/chlorine analysis and sulfur analysis including oxygen correction.

(3) Auto Ranging

Normal operation includes the use of three different calibration curves. These are for low, middle and high concentrations for most accurate determinations based upon the intensity of the S-Kα X-rays. These calibrations can be combined to form a single curve to simplify operation.

(4) Replacement of the vacuum window

The mono-chromatic X-ray beam exits through the Kapton® Window to hit the sample cell. This window can easily be replaced by a normal operator. Replacement windows are provided to the user as a part of the ship kit.

Instrument Applications

(1) Sulfur in petroleum products

With an LOD lower than 1 mg/kg, this instrument is useful for all standard fuel samples. Since the instrument has been shown to be compliant with ASTM D4294, it can also be used for high sulfur samples such as crude oil and residual oil.

(2) Sulfur in Biofuels

Due to addition of an oxygen correction factor ethanol, biodiesel, reformulated gasoline and biodiesel blends can be analyzed. These oxygen correction factors are derived from the measurement of the scattered X-ray from oxygen. This all happens automatically with no intervention by the operator.

(3) Chlorine in petroleum products

The fluorescence for the Cl-Kα peak is closer to the excitation energy of the Ag-La than is S-Kα. Thus the chlorine produces a stronger peak and so provides good sensitivity. The LOD for the chlorine is thus less than 0.6 mg/kg. The

biggest challenge is that in many cases the chlorine appears in a sample which has very high sulfur concentrations. With proper peak separation of the sulfur and chlorine the chlorine can be accurately measured. A good example is ASTM method D4929.

Conclusion

The MESA-7220V2 complies with a series of ASTM methods. From D7220 to D4294 plus D4929, this instrument has proven to be very useful. The application will only continue to grow in the future.

* This content is based on our investigation at the year of issue unless otherwise stated.

References

- [1] Sumito Ohzawa: "Sulfur in Oil Analyzer SLFA-60", p.109, *Readout* (HORIBA Technical Report), 42 (2014)
- [2] Cynthia G. Zoski: "5.2.1 Highly oriented pyrolytic graphite", p.115, *Handbook of Electrochemistry* (2007).
- [3] Jeroen A. Van Bokhoven, Carlo Lamberti: "6.6.2 X-ray emission spectrometers", p.141, *X-Ray Absorption and X-Ray Emission Spectroscopy: Theory and Applications* (2016).



UEDA Hideo

Scientific & Semiconductor Instruments R&D Dept.
Research & Development Division
HORIBA, Ltd.



Michael POHL, Ph.D.

Vice President
Horiba Instruments, Inc.

Product Introduction

Development of the Ambient Carbon Dioxide Monitor APCA-370

NAGASAWA Kenya

MIZUNO Yusuke

In recent years, there has been an increasing need to measure carbon dioxide (CO₂) in our atmosphere with high accuracy. This is due to the necessity of measuring, controlling, and reducing the emissions of the greenhouse gas, CO₂, in each country participating in the Paris Agreement. The HORIBA APCA-370 is a device that measures carbon dioxide in the atmosphere with high accuracy. This has been achieved by adopting our unique measurement technology method, cross flow modulation, and a self-regenerating CO₂ purifier. This paper introduces the development history and features of the APCA-370 in detail.

Introduction

Reduction of greenhouse gases emissions - CO₂, nitrous oxide, methane, and others - is one of the goals for the Paris Agreement adopted in 2015. The monitoring of CO₂ concentration in our atmosphere has been attracting attention, and the requirements for monitoring CO₂ has been increasing year over year, especially in Europe.

Since the early 1960s, many countries have been measuring CO₂ in areas with low anthropogenic emissions (abbreviated as background CO₂ monitoring). This is led by the WMO (World Meteorological Organization) to clarify long-term global changes in atmospheric components that effect weather and climate. In Japan, the Japan Meteorological Agency has released data collected from Ryori Village (Iwate Prefecture), Minamitori Island (Ogasawara Village, Tokyo), and Yonaguni Island (Okinawa Prefecture). Recent measurements of CO₂ concentration have exceeded 400 ppm. This concentration increased by 47% compared with the average value of 278 ppm before the Industrial Revolution (around 1750).^[1]

Technologies for capturing and effectively utilizing emitted CO₂ have been developed and have been a key to minimizing CO₂ emissions. Highly sensitive measurement of CO₂ is essential for detecting the leakage of captured CO₂. A device that measures CO₂ with high sensitivity, high accuracy, and long-term stability is required for the background CO₂ monitoring and the leakage of captured CO₂. The HORIBA APCA-370 was developed to satisfy these requirements.

Product Overview

Generally, when a molecule composed of two or more different atoms is irradiated with infrared light, the molecule will absorb the infrared light with specific wavelength based on the energy levels of vibration and rotational motion of the molecule. Non-dispersive infrared absorption (NDIR) performs quantitative analysis by measuring the amount of specific wavelength absorption of a molecule. The change in the amount of infrared absorption depends on the concentration of the absorbing molecule (the measuring gas). This relationship is expressed by the Lambert-Beer law of Equation 1.

$$I = I_0 \exp(-mcd) \dots \dots \dots (1)$$

- I₀ : Intensity of incident light
- I : Intensity of transmitted light
- c : Concentration of absorbing molecule (measuring gas)
- m: absorption coefficient (constant determined by molecule and wavelength)
- d : Thickness of absorption molecular layer (gas layer)

Since I₀, μ and d are constants that can be determined by the type of measuring gas component and the device, the concentration of measuring gas, c, can be determined by measuring the intensity of transmitted light, I. For the measurement of CO₂, the NDIR method is widely used because CO₂ has strong absorption in the infrared region. NDIR is simple in structure, easy to maintain, and suitable for continuous measurement.^[2]

Double beam type NDIR has been used in our measurement of CO₂. Figure 1 shows the schematic diagram of a

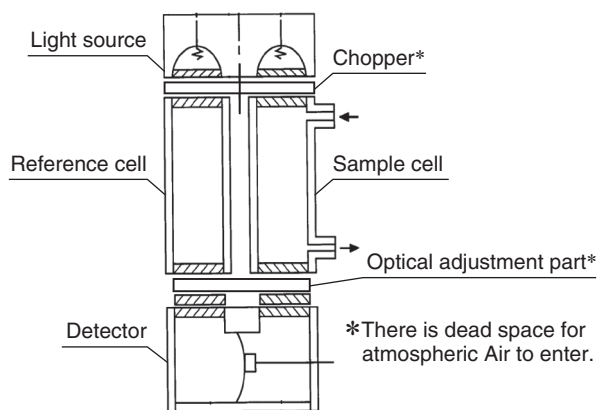

Figure 1 Schematic diagram of a double beam type NDIR

double beam type NDIR. The infrared light emitted from the light source passes through the sample cell and the reference cell and enters the detector. The transmitted light in the sample cell and reference cell enter the detector alternately via the splitting of infrared light by a continuously rotating optical chopper. The amount of infrared light entering the sample cell and the reference cell is adjusted to be substantially equal in the optical adjustment part. The intensity of the transmitted light that passes through the sample cell will decrease as the result of the proportion of absorption of infrared light to CO₂ concentration present. The intensity of transmitted light passing through the reference cell will remain unchanged due to the presence of a sealed gas that does not absorb infrared light. The difference in the transmitted light is detected by the detector and converted into an electric signal.^[3]

There are two issues in this method when monitoring background CO₂ or detecting leakage of recovered CO₂ with high sensitivity, high accuracy, and long-term stability. The first issue is the effect of change in CO₂ concentration in the dead space. The optical system has some dead space in the structure of the chopper and the light adjustment part. Ambient air containing CO₂ can infiltrate the space. It is possible that when humans are present and exhaling CO₂, the CO₂ concentration in the space is changed, and this change can effect the reading value. This effect is a non-negligible error for highly sensitive measurements of CO₂. Therefore, the dead space must be purged for the CO₂ concentration remains constant, or the optical system must have a structure in which CO₂ does not enter. The second issue is drift. The output at zero reading will drift slightly over time. This is called zero-drift. Successive changes in the reflectance of the sample cell surface and the transmittance of the window both cause zero-drift. This drift brings about a non-negligible error during the measurement of low amounts of CO₂, such as the leakage of the recovered CO₂ described in introduction. Thus, it is necessary to calibrate the mea-

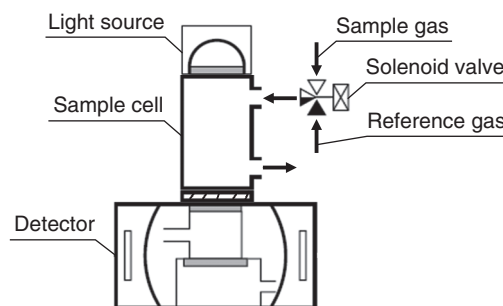

Figure 2 Schematic diagram of a cross-flow modulation type NDIR

surement system more frequently than usual.

To solve this issue, the APCA-370 adopts HORIBA's unique fluid modulation method (cross-flow modulation). Figure 2 shows the basic structure and operating principle. The APCA-370 consists of a light source, a cell, a detector, and a flow modulator (solenoid valve). In an infrared analyzer using the cross-flow modulation method, fixed amounts of sample gas and reference gas that does not contain CO₂ are alternately introduced into the sample cell by solenoid valve, and an alternating current is produced as a signal as a result of the two gases different absorption strengths. Therefore, the cross-flow modulation without optical chopper part and light adjustment part is designed to minimize the dead space. The change of the condition of the cell window surface and reflectivity of the cell inner wall surface over certain periods can

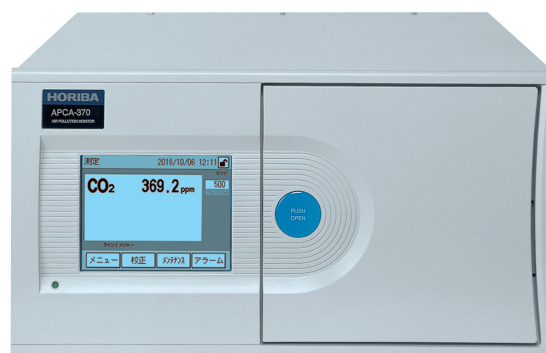

Figure 3 External Appearance of the APCA-370

Table 1 Specification of APCA-370

Measurement principle	NDIR	
Measurement target	Carbon dioxide (CO ₂) in ambient air	
Range	0 to 500/1000 ppm	
Lower detectable limit	0.5 ppm (2σ)	
Reproducibility (repeating accuracy)	± 1.0% of the full scale	
Linearity (readout error)	± 2.0 % of the full scale	
Zero drift	± 1.0 ppm/day	
Span drift	± 2.0 % of the full scale/day	
Response time	60 sec or shorter (T ₉₀ from the inlet)	
Gas flow rate	Approximately 0.7 L/min	
External dimensions	(W)	430 mm
	(H)	221 mm
	(D)	550 mm
mass	Approximately 20 kg	

be canceled by supplying a sample gas and reference gas to only one cell when detecting gas concentration. Cross-flow modulation has very low zero-drift.^[3,4] The external appearance and main specifications of the APCA-370 system are shown in Figure 3 and Table 1.

Adoption of Self-regenerating CO₂ purifier

What is important in adopting the cross flow modulation method is the CO₂ content contained in the reference gas. As described above, in the cross-flow modulation method, the measured value is the difference in the concentration of CO₂ between the sample gas and the reference gas. Therefore, the amount of CO₂ contained in the reference gas is one of the measurement errors. There are two methods for supplying reference gas. These are by using a gas cylinder without CO₂ or removing CO₂ from the atmosphere or sample gas with the adsorbent and purifying it to the reference gas. The gas cylinder needs to be changed frequently as the cross-flow modulation requires large amounts of reference gas. Frequent replacement of gas cylinders increases the burden on the user.

Soda lime is used to purify CO₂. Regeneration is difficult and the adsorbent must be replaced periodically. This makes maintenance relatively complicated, but not as much as replacing the gas cylinder. Therefore, the APCA-370 adopts an adsorbent that has a high adsorption performance for CO₂, and desorbs CO₂ when the temperature is increased. The APCA-370 has two purifiers packed with adsorbent. One is performing reference gas purification, while the other is performing regeneration with increasing temperature. Purification and regeneration operations are performed alternately, and a reference gas is always introduced into the sample cell to enable continuous measurement.

A uniqueness to minimize consumption of adsorbents in the purifier.

APCA-370 reuses the reference gas as a purification gas in its gas flow system as shown in Figure 4, and therefore it enables to reduce consumption of adsorbents in the purifier. The sample gas (Q1) is introduced from the sample inlet and flows into the sample cell by passing through the solenoid valve. The gas is then introduced to the purifier (Q2). Some of the gas are used as a reference gas returning to the sample cell without CO₂ (Q3), and the rest of the gas is for a purification gas to regenerate ability of adsorption in the purifier (Q4). The returning reference gas (Q3) flows into the sample cell and comes back to the purifier again. Hence, the types of gas introduced into the purifier during the operation are followings: sample gas with CO₂ and reference gas without CO₂. As a result, total

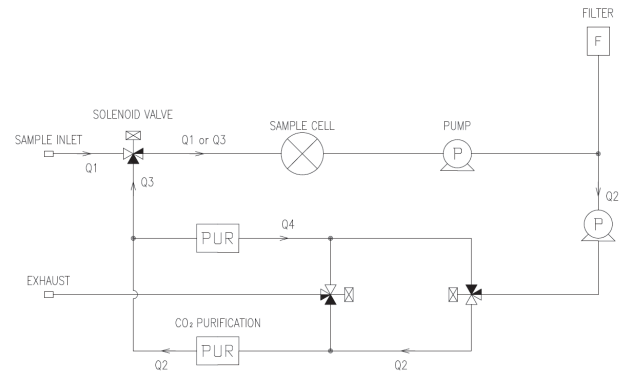

Figure 4 Schematic diagram of APCA-370 gas flow

consumption of adsorbents in the purifier is significantly reduced, compared with the system in which the sample gas with CO₂ keeps coming into the purifier. APCA-370 is able to reduce consumption of adsorbents down to 40% from conventional gas flow systems.

Verification test

A demonstration test of APCA-370 was conducted from May 24, 2019 to December 6, 2019 at an air quality monitoring station (AQMS) in our factory. AQMS is shown in Figure 5. The device periodically introduces 0 ppm gas without calibration, and the results are shown in Figure 6. Zero-drift was about 0.1 ppm at the maximum in six months, and the drift amount was below the Lower detectable limit. These results indicate that APCA-370



Figure 5 Air Quality Monitoring Station (AQMS)

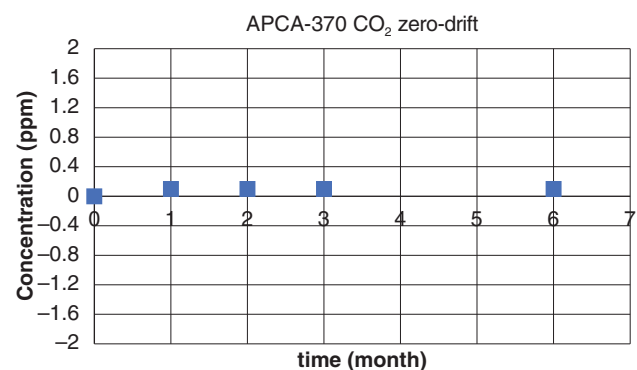

Figure 6 The result of zero-drift

has low zero-drift and can perform long-term stable measurement.

Conclusion

At present, with the increasing public interest in environmental issues, highly accurate and highly reliable atmospheric measurement devices are required. The APCA-370 introduced here is expected to be applied not only to background CO₂ monitoring but also to various fields such as indoor CO₂ monitoring for which demand will increase in the near future. Our mission as a comprehensive manufacture of analytical instrument, is to improve the APCA-370 actively develop domestic and overseas markets, meet customer and contribute to society.

* This content is based on our investigation at the year of issue unless otherwise stated.

References

- [1] “二酸化炭素濃度の経年変化” 気象庁. 2020-01-21.
 (“change over the years of carbon dioxide” Japan Meteorological Agency. 2020-01-21)
https://ds.data.jma.go.jp/ghg/kanshi/ghgp/co2_trend.html,
(accessed 2020-02-26)
- [2] Junji AOKI, Pneumatic Infrared Detector, *Readout*, 7, 64-71(1993).
- [3] Kazunori MIZUMOTO, Development of the Multi-Component Gas Analyzer VA-5000 Series, *Readout*, 51, (2018)
- [4] Takao IMAKI, Monitoring System for atmospheric CO₂, *Readout*, 1, 33-39(1990)



NAGASAWA Kenya

Process & Environmental Instruments R&D Dept.
Research & Development Division
HORIBA, Ltd.



MIZUNO Yusuke

Deputy Dept. Manager
Process & Environmental Instruments R&D Dept.
Research & Development Division
HORIBA, Ltd.

Product Introduction

Development of the WQ-300 Series Multi-digital Water Quality Meter

KOMATSU Yuichiro

We developed the WQ-300 series of multi-digital water quality analyzers that can simultaneously select three items from pH, dissolved oxygen (DO), electrical conductivity, oxidation-reduction potential (ORP), and ion measurement items. The WQ-300 series includes a pH sensor with a non-refillable reference electrode that does not require replenishment of the internal solution, a 4-pole electrical conductivity sensor that can measure a wide range, and an optical DO sensor that is less affected by flow rate. Compared to the previous model of portable water quality meter, simultaneous display of all items with color graphic LCD, push-pull lock type connector for easy attachment/detachment of sensor, USB power supply for measuring without worrying about battery capacity, installation on the ground even though the screen is easy to see, the meter stand that supports operability, the wireless communication function that can wirelessly transfer stored data, and usability have been greatly improved. Therefore, the WQ-300 series is expected to be able to contribute to environmental water measurement beyond the range of conventional portable water quality meters.

Introduction

It is essential to measure the basic characteristics of water, such as water temperature, pH, electrical conductivity, and dissolved oxygen for environmental water monitoring, sewage maintenance, periodic inspection of construction site and factory wastewater. Since it takes time and effort to measure each measurement with each instrument, a multi water quality meter that can measure many items at once is often used. We have developed a U-50 multi water quality meter for these applications. The multi water quality meter has built-in sensors such as pH, electric conductivity, dissolved oxygen (DO), oxidation-reduction potential (ORP), turbidity, water depth and water temperature in a portable size device. However, a multi water quality measurement device is expensive and maintenance is difficult in surface water measurement that does not require a depth direction and indoor measurement of a sample collected on site. Therefore, we decided to develop a new WQ-300 series that can solve these disadvantages and market requirements.

Product overview

Figure 1 shows a multi-digital water quality meter. The weight of the meter and each sensor is very light, near 0.4 kg and near 0.2 kg. Up to 3 sensors can be connected to

the meter, and measurements can be made by immersing the sensor in the sample. The meter is equipped with a screen that efficiently collects external light in the liquid crystal, which not only displays measurement items in a batch, but also realizes a screen that is easy to see in direct sunlight as well as in dark places. Until the conventional product, the analog data detected by the sensor was subjected to digital conversion processing on the meter side. However, as a drawback, it is possible to measure



Figure 1 Product outline

only measurement item depending on the electronic board built in the meter, so there is no scalability. Further, the calibration data and the measurement settings are not inherited and the function does not work unless the meter and the sensor are paired when the sensor is replaced with another meter. As shown in Figure 1, the WQ-300 series solves these disadvantages by moving the electronic board from the meter to the sensor. A digital circuit is built in the sensor head and can hold information on measurement. The sensor is environmentally friendly, and the operation cost and the maintainability in on-site measurement are improved since the sensor is a replaceable cartridge type. In addition, conventional products often fluctuated the measured value due to noise from the outside. However, it is possible to measure with less noise effect by moving the digital circuit close to the sensor. Since data from the sensor to the meter is transferred digitally, this product can eliminate the noise effect and the increase in internal resistance due to the cable length. It can be extended to future water quality products.

Designed for a series of operations related to measurement

A carry case was prepared for the product to carry all the equipment required for on-site measurements. As shown in Figure 2, in the storage space, a replacement battery, calibration standard solutions, and an instruction manual can be stored in addition to a meter and sensors. This makes it possible to calibrate immediately before measurement after heading to the site, and also to evaluate by standard solution measurement for product confirmation when there is a problem with any measured value. The internal structure of the carry case is provided with a storage space according to the shape of the product and a storage space for cables that tend to be complicated when stored. Further, since it is difficult to prepare a sensor stand at the site, as in a laboratory, the calibration standard solution bottle can be fixedly installed and provided



Figure 2 Carry Case outline

with a self-standing structure even if the sensor is immersed as it is. Therefore, all preparations can be completed in this case. The case is designed a series of operations of calibration, measurement, and setting can be smoothly performed so that the user only needs to take out the device after preparation.

Designed for simultaneous measurement

It was designed to be easy to carry during the operation of measuring the sample on site, and it is easy to handle 3 sensors (Figure 3 (left)). The meter is coated with soft resin to provide non-slip grip and not easily damage even if the product falls. Sensors can be mounted on 3 holders on the meter for carrying (see Figure 3), and each sensor head has 2 holders and one hook which can be used to attach up to 3 sensor heads during on-site measurement. This structure has made it possible to perform measurements with the measurement detection position of multiple sensors aligned (Figure 3 (right)).



Figure 3 Sensor holders and hooks

High-precision measurement independent of the environment at the measurement site

The sensor developed for the WQ-300 series was designed with high precision in field measurement and operability. The newly developed pH sensor uses KCl gel electrolyte formed in the bio polycarbonate housing which does not

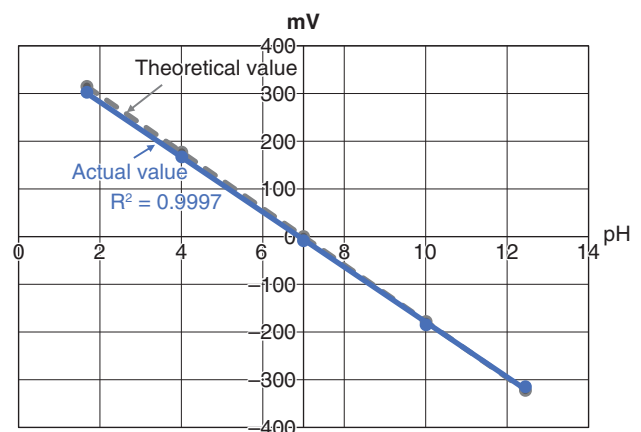

Figure 4 Linearity of non-filled type pH sensor

need to refill the internal solution for the reference electrode in order to facilitate daily pre-measurement preparation and on-site measurement. As shown in Figure 4, even on the acid side and the alkali side, the correlation coefficient with respect to the theoretical value is 0.9997, which can be measured with high accuracy. Regarding the electric conductivity measurement, as shown in Figure 5, the four-pole electric conductivity measuring method that can measure a wide range with high accuracy was adopted. Since the sensor is made of carbon, it can be brush- cleaned for physical contamination caused by a turbid sample. For the DO measurement, as shown in Figure 6, the optical dissolved oxygen method that can reduce the influence of the flow rate is adopted. In addition, the meter is equipped with an atmospheric pressure detector, which performs automatic atmospheric pressure correction when calibrating the DO value that changes with the atmospheric pressure of the measurement environment. Furthermore, by combining with an electric conductivity sensor, the salt concentration is converted from the electric conductivity value measured from the sample, and the salt value is automatically corrected to the DO value. In this way, by using these functions provided in the product to compensate for environmental changes related to measured values, highly accurate measurements that are not affected by the measurement environment can be performed automatically.

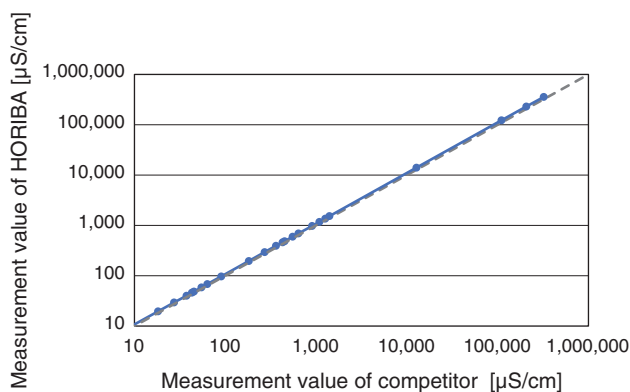

Figure 5 Linearity of 4-cell conductivity sensor

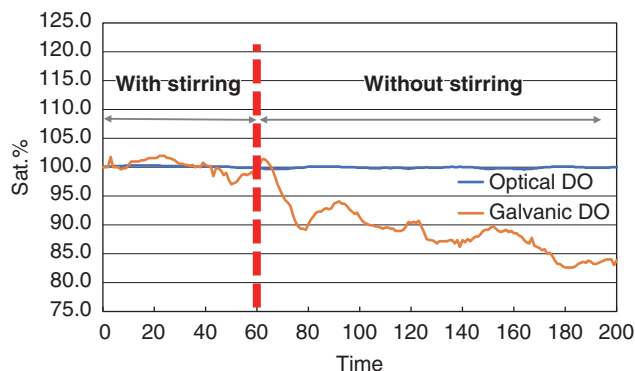

Figure 6 Comparison of flow rate effect of common electrochemical and fluorescent DO sensor

Conclusion

The multi-digital water quality meter WQ-300 series introduced this time enables high-precision measurement by automatically compensating for measurement errors due to environmental changes, in addition to the product design that enables smooth on-site and also laboratory measurement. Further, the measurement range is expanded and handling is facilitated. Therefore, the measurement of environmental water can be performed more easily and with higher accuracy than previous products, and this product can also be used for applications that require simultaneous measurement according to environmental effects.

The deep blue seas, clear beautiful rivers, highly transparent lakes and marshes, water is a life-essential resource. However, our precious water resources are threatened by various human activities that generate waste water, such as sewage water, plant waste water, and agricultural waste water. This leads to eutrophication and organic pollutant contamination, resulting in wide-scale environmental destruction. This problem is common all over the world, and tasks analysis instrument manufacturers with the important role of providing instruments for accurately monitoring and controlling water quality. To that end, we are committed to continue developing water quality measuring equipment as our contribution to environmental problem solutions; supply water control; and sewage treatment process control.

* This content is based on our investigation at the year of issue unless otherwise stated.



KOMATSU Yuichiro

New Product Development Department 1
 Research & Development Division
 HORIBA Advanced Techno, Co., Ltd.

Product Introduction

Industrial Gel-Filled pH Electrode 6155

KINOSHITA Takamasa

ITO Yuichi

NISHIO Yuji

MUROGA Tatsuoki

We have developed “Industrial Gel-filled pH Electrode 6155”. One of the features of this product is that polymer gel including potassium chloride (KCl) solution, instead of KCl solution itself, is filled inside of its reference electrode. This improves usability during maintenance because there is no need to replenish the internal solution. Besides, water pressure resistance is also improved comparing with general liquid-filled electrodes. Another feature is double structure of liquid junction, which reduced measurement errors in fast-flowing low conductive samples to less than one tenth of our existing electrodes. We are proud to provide satisfying pH measurement to further a wider range of customers by the development of this product. In this article, we explain the feature of the 6155 electrode in detail, and introduce examples of measurements in some fields.

Introduction

HORIBA group has been developing and providing pH electrodes over 60 years since Masao Horiba, who is the founder of HORIBA, developed a first glass pH electrode in Japan. Now, HORIBA pH electrodes are used for water quality management in various fields, such as water and wastewater treatment plants and process water treatment facilities in many kinds of factories. In such fields, pH electrodes are frequently placed in harsh environment, and are required accurate measurement with continuity and durability. In order to meet the needs of diverse fields, we have been lining up many kinds of pH electrodes, such as hydrofluoric acid-resistant electrodes and alkali-resistant pH electrodes.^[1]

Whereas, customer demands are so diverse that we have still challenges for improvement in order to use pH electrodes more easily in a variety of site. For example, simplification of maintenance is sought by many customers because general pH electrodes require laborious operations during maintenance like calibration and washing. Also, the pH electrodes generally have problems such as short life at a site with high pressure, and measurement error at a site with high flow rate. Therefore, we have developed “Industrial Gel-filled pH Electrode 6155” that has advantages in the following three points (Figure 1).

- Usability (Ease of maintenance)
- Pressure resistance
- Accuracy of low conductivity sample measurements

In this article, we explain the advantages of the 6155 electrode comparing with general electrodes, and introduce examples of measurement in some fields.



Figure 1 A photographic image of the industrial gel-filled pH electrode 6155.

Structure of pH electrode and the measurement principle

A general method of glass electrode is adopted for pH measurement of 6155 electrode. At first, the method is explained as follows.^[2]

A glass pH electrode is composed of a glass electrode and a reference electrode (Figure 2). Hydration layers are formed in the wetted part inside and outside of response

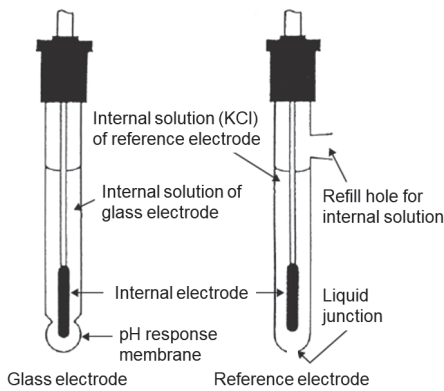

Figure 2 A structural image of a fundamental pH electrode.

glass membrane when a glass electrode is soaked in a sample solution. As a result, an electric potential is generated proportional to the pH difference between internal and sample solution. A reference electrode, internal potassium chloride (KCl) solution is connected with a sample solution via liquid junction, generates constant potential regardless of pH. The pH is calculated by Equation 1, depending on potential difference between the glass electrode and the reference electrode, and liquid temperature.

$$pH(X) = (E_x - E_s) / (2.3026RT/F) + pH(S) \dots\dots\dots (1)$$

- pH(X): pH of a sample solution
- pH(S) : pH of a standard solution for calibration
- E_x*: Potential difference measured in a sample solution
- E_s*: Potential difference measured in a standard solution for calibration
- R: Gas constant
- T: Absolute temperature
- F: Faraday constant

Most of current pH electrodes are composite pH electrodes composed of a glass electrode, a reference electrode, and a temperature sensor (Figure 3). The 6155 electrode is also the composite pH electrode.

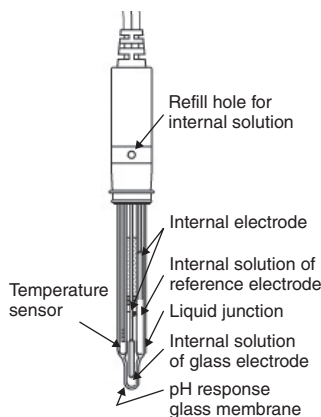

Figure 3 A structural image of a composite pH electrode.

Features and advantages of the 6155 electrode compared with general electrodes

In this section, we explain structural features of the 6155 electrode and its advantages comparing with existing pH electrode of our company.

Good usability

One of the features of the 6155 electrode is that polymer gel including saturated potassium chloride (KCl) solution is filled inside of its reference electrode instead of KCl solution (Figure 4). Since this polymer gel has a strong binding property and is insoluble in water, it has the following advantages.

- (1) Chemical resistance.
- (2) No containing of microbial nutrition (Mold free).
- (3) No flowing out into sample solution (Long life).

Also, the KCl saturation state is maintained for long term since KCl granules is also added in the polymer gel. Accordingly, the 6155 electrode can be used in various kinds of fields for long term without refill of internal solution.

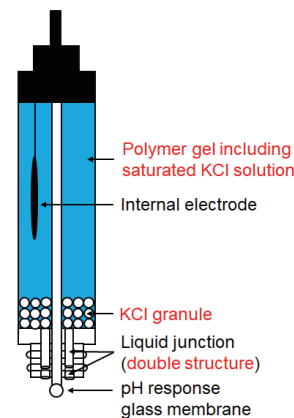

Figure 4 A structural image of the 6155 electrode.

Gel-filled pH electrodes have advantages of usability in regard to installation, and maintenance like calibration and washing. Generally, a refill tank for internal solution is installed to conventional liquid-filled electrodes since securing of internal solution volume is necessary in order to extend maintenance cycle (Figure 5). The holder of the electrode with KCl tank becomes heavy, but if the holder is not kept vertical, the internal solution spills out of the refill tank. Therefore, it is not easy to perform the maintenance by one person, and it may be dangerous at a site where a working space is not sufficient (Figure 6 left). On the other hand, the gel-filled 6155 electrode does not need to be attached the refill tank. As the result, the electrode and its holder become lightweight. Accordingly,

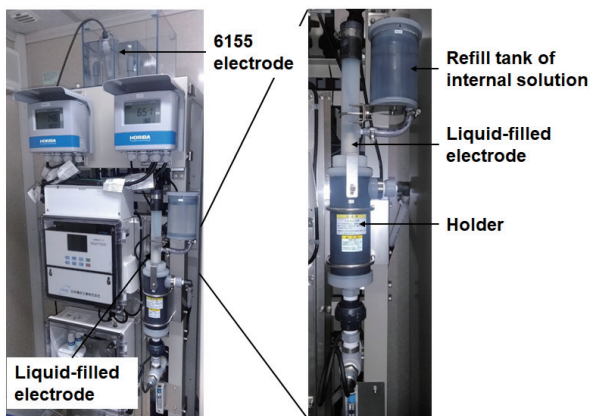

Figure 5 Photographic images of a general installed liquid-filled electrode of our company and a 6155 electrode.

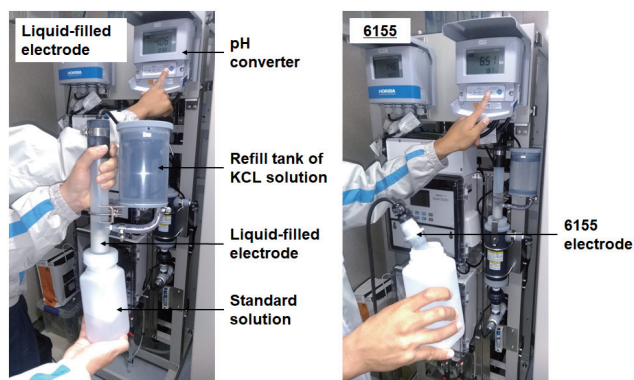

Figure 6 Photographic images of calibration of a general liquid-filled electrode of our company and a 6155 electrode.

the work at the time of installation is simplified by reduction of number of parts as well as ease maintenance by one person is possible (Figure 6 right).

Improvement of pressure resistance

As described above, inside of a reference electrode is connected with sample solution via liquid junction. In liquid-filled electrodes, sample solution backflows into the inside of the electrode when pressure is applied from the sample side. This provokes dilution and/or disruption of the internal solution, resulting in inaccurate pH measurement. We deal with the problem by pressurizing the internal solution toward the sample side, however, it is difficult to control the pressure completely. The backflow was not

prevented when the sample pressure exceeds the pressurized value set by the user. Whereas, outflow of the internal solution is accelerated when the sample pressure is lower than the pressurized value. In this case, shortening the maintenance cycle becomes a problem.

With regard to the 6155 electrode, the water insoluble polymer gel, which hardly resolves to the sample side, is filled inside of the reference electrode without any gaps. Therefore, the backflow of the sample solution hardly occur. Accordingly, accurate pH measurement can be performed for a long period with few maintenance even under high-pressure condition such as in a closed pipe line. In fact, it has been confirmed that the 6155 electrode is used until 0.7 MPa of pressure, which is about seven times as much as atmospheric pressure.

Accuracy of low conductivity sample measurements

General pH electrodes occur measurement error when measuring fast-flowing sample solution. It is assumed that the measure cause is flow potential generated when liquid moves inside the capillary (Figure 7 left). Degree of the measurement error caused by the flow potential is notable when conductivity of the liquid in the capillary is low. Therefore, we should consider the error, in case solution containing little ions such as ion-exchange water, groundwater, and tap water is measured.

We adopted inside the capillary (Figure 7 left) a double structure liquid junction composed of a porous ceramic part, generally used as liquid junction, and a porous polyethylene (PE) part for the 6155 electrode. The flow potential could be reduced even in the low electric conductivity sample since the flow rate is reduced inside of the PE part (center in Figure 7). We investigated pH difference with and without flow rate, using sample solution with 100 $\mu\text{S}/\text{cm}$ of conductivity, which is as low as tap water. It is revealed that the pH difference of the 6155 electrode was less than 1/10 of other three kinds of conventional electrodes (Figure 7 right). Besides, the 6155 electrode can measure flowing samples with 10 $\mu\text{S}/\text{cm}$ of conductivity within 0.1pH difference under normal pressure condition,

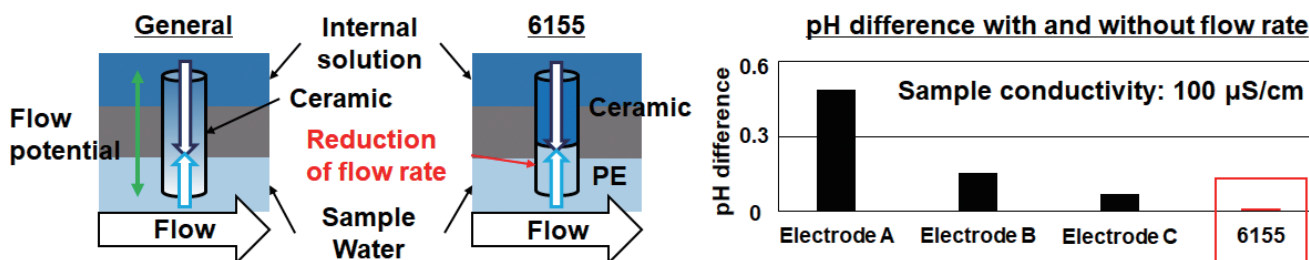

Figure 7 Illustration images of liquid junction part, and pH difference with and without flow rate, in regard to general electrodes and a 6155 electrode.

as long as keeping liquid junction to clean.

Measurement examples in some fields

Field evaluation revealed that the 6155 electrode can continue stable pH measurement in many kinds of samples. Further, even in the field where various kinds of dirt such as inorganic, organic, and microorganisms pose a problem, it can be used with a low maintenance frequency by combination with our automatic cleaners, such as an ultrasonic cleaner and a water jet cleaner. Examples of the sites where the field evaluation were performed are shown below.

- Intake of water purification plant with a sample electric conductivity of about 100 $\mu\text{S}/\text{cm}$
- Reverse osmosis membrane treatment process with a sample pressure of 0.3 MPa
- Groundwater with a sample pressure of 0.5 MPa and an electrical conductivity of about 40 $\mu\text{S}/\text{cm}$
- Aeration tank in a wastewater treatment facility (Figure 8)
- Anaerobic treatment process of wastewater treatment facility (combined with ultrasonic cleaner)
- Factory drainage (combined with water jet cleaner)

Figure 8 shows a comparison between the reference electrode standard potential of the 6155 electrode and a gel-filled pH electrode made by other company, electrode X, in the aeration tank of the wastewater treatment facility. The standard potential depends on the KCl concentration of the internal solution (or gel), and is generally around 0 mV under the regular condition. The standard potential of the 6155 electrode (pink line) shows 0 ± 10 mV for 3 years, which means that the pH shift caused by the reference electrode is within $\pm 0.15\text{pH}$. Also, there are not confirmed drift tendency of the potential for 3 years. Electrode X also showed the almost same pattern as the 6155 electrode for first one year, however, there are confirmed a potential drift to the positive direction after

that. One and a half years later, the standard potential shifted to more than 30 mV (0.5 pH). This is attributed to dilution of KCl concentration in the polymer gel due to sample invasion from liquid junction.

Since the polymer gel of the 6155 electrode is a water-insoluble gel having excellent chemical resistance, change in composition and reduction of the included KCl concentration by sample invasion hardly occur. Further, the KCl-saturated state in the polymer gel is maintained even if the sample is mixed, since KCl granule is contained there. The granules gradually dissolve by contact with the sample solution, but the amount are designed to withstand the continuous immersion for more than two years at normal temperature and pressure. By this field test, it is confirmed that the 6155 electrode actually had a lifetime of more than 2 years although it may depends on environment and kinds of sample.

In addition, a combination of the 6155 electrode and our automatic ultrasonic cleaner was evaluated in an anaerobic treatment process of wastewater treatment facility. According to the customer, existing pH electrode made by other company had to be manually cleaned every day for accurate measurement since dirt is remarkably adhered to the response membrane and liquid junction. The continuous measurement values of the 6155 electrode and the existing electrode were compared at the same site. The measurement value of the 6155 electrode reacted dynamically at timings when no shift was observed in the existing electrode. According to the customer, this indicates that the 6155 electrode was accurately following pH shift of the sample. Further, it was found that the 6155 electrode can continue accurate measurement for more than two weeks at this site without cleaning. In the result, the cycle of manual cleaning by the customer could be significantly reduced. Now, the 6155 electrode have been implemented for more than six months at that site. The customer has commented as “Excellent measurement have been continued.”

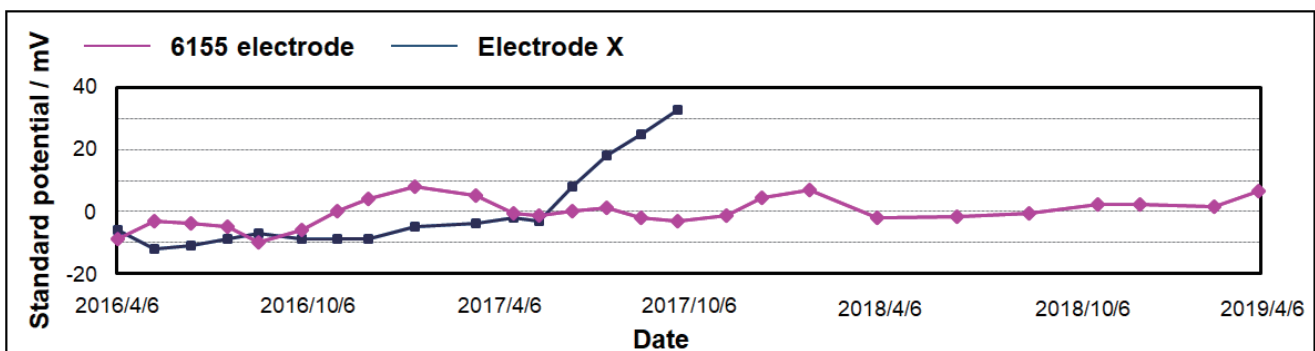

Figure 8 Comparison of continuous measurement of reference electrode standard potentials in activated sludge layer of wastewater treatment facility between the 6155 electrode and pH electrode made by other company.

Conclusion

pH electrodes have been used for various purposes for long time since they were firstly produced by Beckmann in 1935 in the world, by Masao Horiba in 1950 in Japan. However, there are a lot of rooms for improvement in order to meet diverse requirement in various fields. We have developed “Industrial Gel-filled pH Electrode 6155” which has advantages of usability, pressure-resistance, and low-conductivity sample measurement. We proud of providing pH measurement satisfied for further more customers, although we have ever been lining up various kinds of pH electrodes. We will make further efforts to contribute water quality by providing many sensors that matches customer’s requirement.

* This content is based on our investigation at the year of issue unless otherwise stated.

References

- [1] Susumu Yamauchi, “Introduction of the New H-1 Series Water Quality Instruments”, *Readout*, **37**, 88 (2010)
- [2] Hiromi Okawa, Yuji Nishio, “堀場製作所の基礎技術2 pH電極”, *Readout*, **41**, 60 (2013)



KINOSHITA Takamasa

New Product Development Department 1
Research & Development Division
HORIBA Advanced Techno, Co, Ltd.



ITO Yuichi

Global Development Department
Research & Development Division
HORIBA Advanced Techno, Co, Ltd.,



NISHIO Yuji

New Product Development Department 1
Research & Development Division
HORIBA Advanced Techno, Co, Ltd.

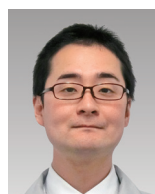

MUROGA Tatsuoki

New Product Development Department 1
Research & Development Division
HORIBA Advanced Techno, Co, Ltd.

Evaluation of Infrared Thermometer for Reduction of Influence of Gas Absorption by Optimization of Spectral Response

FUJINO Sho

Recently high-accuracy temperature measurement becomes more important in semiconductor and flat panel display (FPD) manufacturing processes. Especially the demand for non-contact thermometer is increasing. However, semiconductor manufacturing equipment uses high concentration reactive gases. These gases make it difficult to measure the temperature with high accuracy and repeatability, because the reactive gases absorb the infrared rays. We have developed the infrared thermometer using an infrared filter through which infrared rays of the wavelength with low reactive gas absorption pass. The influence of the NH₃ gas absorption of the infrared thermometer can be significantly reduced. Furthermore, the temperature of the measuring object in the reactive gas can be measured more accurately.

Introduction

Recently high-accuracy temperature measurement becomes more important in semiconductor and flat panel display (FPD) manufacturing processes. Especially the demand for non-contact thermometer is increasing.

An infrared thermometer, which is one of non-contact thermometers, detects infrared rays radiated from the surface of the object, and it converts them into temperature value. The air between measuring object and infrared thermometer, absorbs infrared rays, therefore, it is necessary to minimize the influence of such absorbance. The spectral characteristics of response of wavelength 8-14 μm light is called “atmospheric window”, where the light shows low absorption with some gases such as water vapor (H₂O), ozone (O₃), and carbon dioxide (CO₂). This spectral response is generally adopted to minimize measurement errors caused by changes in humidity and measurement distance. However, because some semiconductor manufacturing equipment uses high concentration reactive gases that absorb infrared rays, it difficult to measure the temperature with high accuracy and repeatability. In order to solve this problem, we have developed the infrared thermometer using an infrared filter that selectively passes the infrared light in wavelength range with low absorption by such reactive gases.

In this article, we explain the principle of the infrared thermometer and the method of selecting the spectral response condition from the infrared absorption spectrum

of the reactive gas. Then we introduce the evaluation results on the influence of infrared light absorption by the NH₃ gas with the newly developed infrared thermometer based on HORIBA’s infrared thermometer IT-470F-H for semiconductor manufacturing equipment.

Principle

An infrared thermometer can measure temperature of the object without contact detecting infrared rays emitted

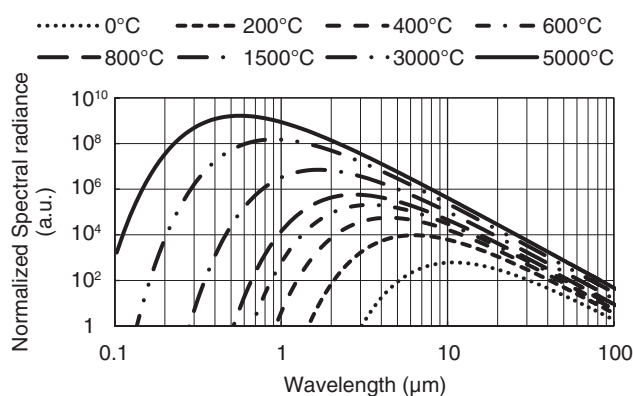

Figure 1 Planck’s law (the relationship between the temperature of an object and the radiation energy emitted by the object)

$$I'(\lambda, T) = \frac{2hc^2}{\lambda^5} \frac{1}{e^{hc/\lambda kT} - 1}$$

- $I'(\lambda, T)$: spectral radiation (J/(s · m² · sr · m))
- T : absolute temperature (K)
 $t(^{\circ}\text{C}) = 273 + t$ (K)
- h : Planck constant (J · s)
- c : speed of light (m/s)
- λ : wavelength (m)
- k : Boltzmann constant (J/K) · m

from the object, and converting an amount of the infrared rays into temperature based on Planck's law. Planck's law shows relationship between the temperature of an object and the radiant energy emitted by the object (Figure 1). For example, a heated 800°C iron plate emits red light, and as the temperature rises, it emits white blight light. On the other hand, objects at room temperature do not emit visible light but emit invisible infrared rays. When your hand is brought close to a hot object, you feel warmth before touching it. In the same way, the infrared thermometer measures the temperature of objects by detecting the amount of infrared energy.

Spectral response

An important factor of an infrared thermometer is spectral response. The spectral response is defined over the wavelength region where the infrared thermometer operates. Generally, the spectral response of the infrared thermometer is configured by incorporating an infrared filter.

Infrared rays are absorbed by carbon dioxide (CO₂), water vapor (H₂O), etc. which are contained in the atmosphere. Infrared absorption wavelength differs depending on gas species and modes of molecular vibration of the gas. Absorption of light transmitting through gases can be expressed using Lambert-Beer's law as follows:

$$A = \frac{E}{E_0} = \exp\left(\frac{-K_A l P}{kT}\right) \dots\dots\dots (1)$$

where A: Absorption, E: transmitted intensity, E₀: incident intensity, K_A: molar attenuation coefficient (cm²/molecule), l: optical path length (cm), P: pressure (Pa), k: Boltzmann constant (m²*kg/(s³*K)), and T: temperature of gas (K).

The gas absorption changes depending on the optical path length, temperature, and pressure. In the case of an infrared thermometer, the optical path length is defined as the distance between the infrared thermometer and the object. This distance varies depending on the application. If the selection of spectral response is incorrect, the temperature of the object can't be measured correctly due to the gas absorption. Specifically, when absolute humidity changes depending on the season, the measured temperature changes. Therefore, the infrared thermometer of spectral response of 8-14 μm is often used because of its relatively small error caused by infrared absorption through gases.

Temperature measurement of the objects in the reactive gas atmosphere

Semiconductor manufacturing process uses several high concentration reactive gases, so it has been difficult to measure temperature with high accuracy due to absorption of infrared rays by these reactive gases in the process equipment. The transmission spectrums of representative reactive gas are shown in Figure 2. The calculation conditions are 1 atm ambient pressure, 25°C gas temperature, 10 mm optical path length, and 100% gas concentration.

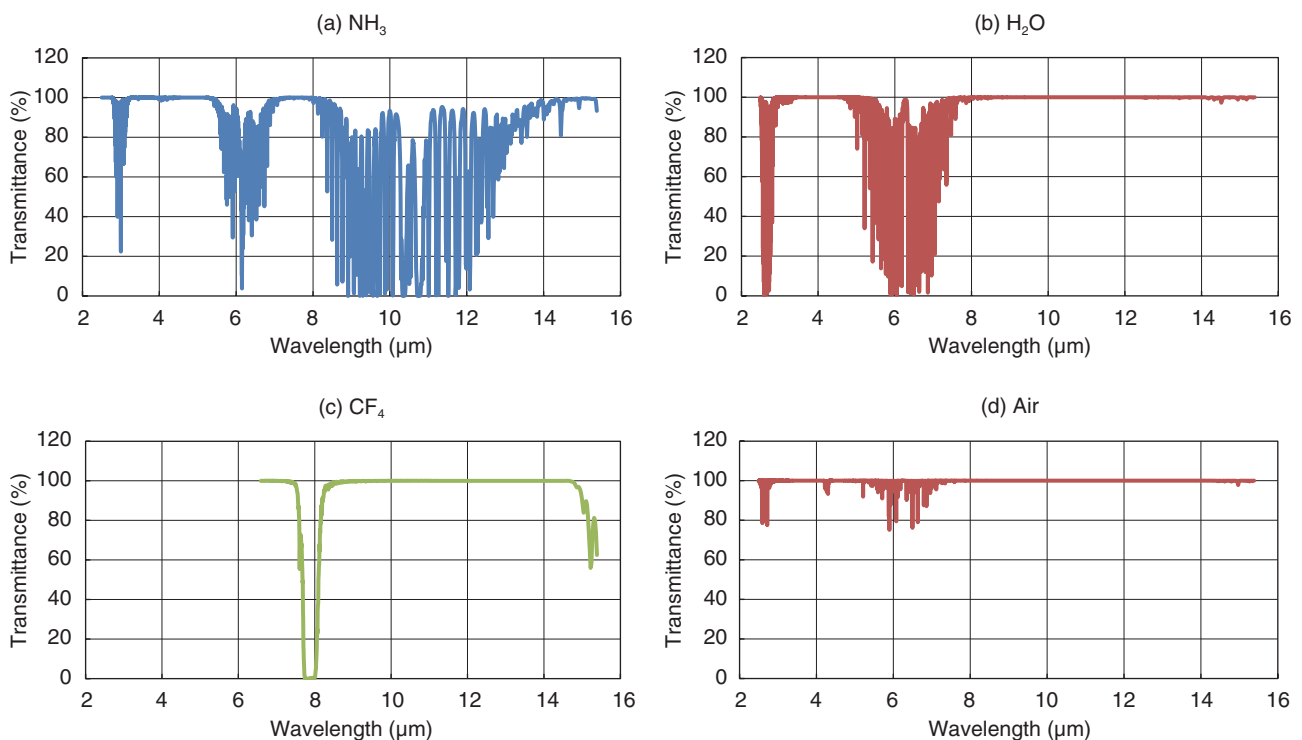

Figure 2 Transmission spectrums of representative reactive gas (1atm, gas temperature 25°C, Optical path length 10mm)

From these transmission spectra, it is necessary to select a wavelength region with relatively few absorption peaks. In the case of ammonia (NH_3) gas, candidates of no large absorption wavelength regions are 3.5-5 μm and 7-8 μm . In these wavelength regions emitted infrared rays can be hardly affected by gas absorption. In the case of water vapor (H_2O), candidates of wavelength region are 3.5-4.5 μm and 8-14 μm . In the case of carbon tetrafluoride (CF_4), a candidate of wavelength region is 9-14 μm .

Selection of spectral response based on Planck's law

In the case of NH_3 gas, it is difficult to use the infrared thermometer with "atmospheric window", because NH_3 gas has many absorption peaks in 8-14 μm . There are two wavelength regions with relatively few absorption peaks of NH_3 gas: 3.5-5 μm and 7-8 μm . It is necessary to consider not only the gas absorption but also the measurement temperature range and the measurement accuracy in order to select the proper spectral response. Figure 3 shows the relationship between the measurement temperature and the amount of infrared energy at each wavelength. We made a comparison between the results in 3.5-5 μm and 7-8 μm . The results in 8-14 μm is also shown as reference data. Taking the measurement accuracy into consideration, it is necessary to secure a sufficient amount of infrared energy in the measurement temperature range. In the case of the measurement temperature with 0 to 200°C, the spectral response in 7-8 μm is advantageous showing larger energy than that in 3.5-5 μm . And then, in the case of the measurement temperature with 200 to 1000°C. The spectral response in 3.5 to 5 μm is advantageous showing larger energy than the results in 7-8 μm . However, the amount of energy of 3.5-5 μm , sharply decreases for less than 200°C, and the amount of infrared energy can't be secured sufficiently. In the case of measuring the temperature of the object in the NH_3 gas, the spectral response in 7-8 μm is comprehensively considered to be advantageous in order to secure the amount of energy in the range from 0°C to 1000°C.

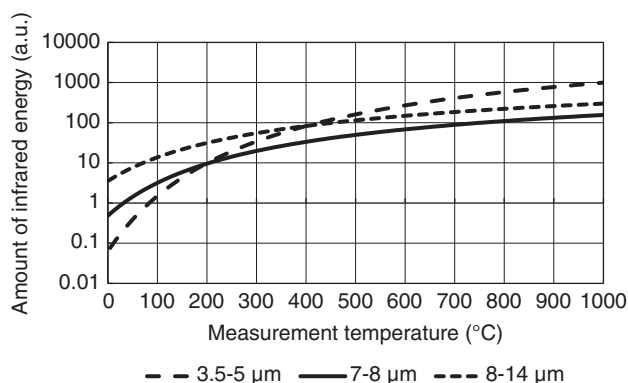

Figure 3 The relationship between the measurement temperature and the amount of infrared energy of each wavelength (Emissivity: 1.000)

Infrared thermometer reduced NH_3 gas absorption

We developed the infrared thermometer based on the infrared thermometer IT-470F-H^[1] (Figure 4) on sale in order to reduce the absorption of NH_3 gas. We decided the spectral response 7-8 μm as described above.

The experimental setup is shown in Figure 5. We evaluated the trend of measuring value change of the infrared thermometer depending on NH_3 gas concentration. We measured the value of the infrared thermometer through the gas cells filled with NH_3 gas. The NH_3 gas concentrations are 0, 15, 50 and 100% at 1atm. The dilute gas is nitrogen (N_2). The thickness filled with NH_3 gas is 10 mm, which corresponds to the optical path length. The infrared window used for the gas cell is made of calcium fluoride with a thickness of 3 mm. The temperature of the gas cell and infrared thermometer is stable at room temperature. The temperature of the heat source was adjusted so that the measuring value of infrared thermometer is 165°C at a gas concentration of 0% (N_2 gas 100%). Two infrared thermometers were prepared using a general 8-14 μm infrared filter and a 7-8 μm infrared filter.



Figure 4 Infrared thermometer for semiconductor production equipment IT-470F-H

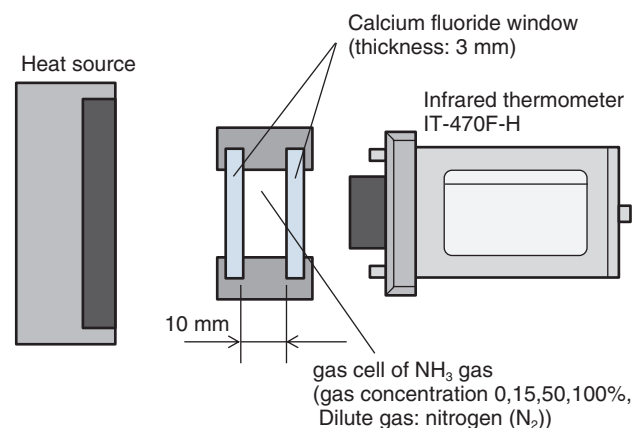

Figure 5 Experimental setup

Results of Infrared thermometer reduced NH₃ gas absorption

Figure 6 shows experimental results and calculation results of measuring temperature from gas spectrum based on the experimental condition. In the case of 8-14 μm spectral response, the measuring temperature decreased as the NH₃ gas concentration increased and decreased by about 20°C at gas concentration of 100%. In the case of 7-8 μm spectral response, the fluctuation between 0% and 100% is within 1°C. These experimental results were in good agreement with this calculation results. It looks that measuring temperature for 7-8 μm spectral response at optical path length 10 mm doesn't decrease against the gas concentration. On the other hand, when the optical path length is 200 mm, calculation results shows that the measuring temperature of 7-8 μm spectral response is only at about 5°C and the measuring temperature of 8-14 μm spectral response at NH₃ gas concentration 100% dropped as much as about 65°C. This is because small absorption peaks appears in 7-8 μm wavelength region due to the optical path length increasing.

The influence of the NH₃ gas absorption on the infrared thermometer could be significantly reduced by selecting the spectral response avoiding the absorption peak of the NH₃ gas. In addition, it was possible to estimate the measuring temperature by calculation when the optical path length is longer.

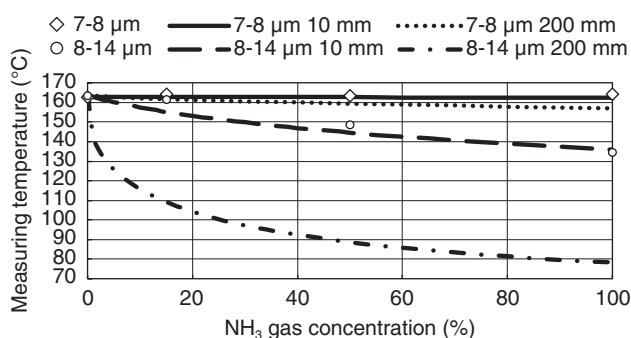

Figure 6 Influence of NH₃ gas absorption about difference of spectrum response
(plot: Experimental result, Dotted line: calculation result)

Conclusion

We have developed the infrared thermometer using an spectral infrared filter through which infrared rays pass with low reactive gas absorption. The influence of the NH₃ gas absorption on the infrared thermometer can be significantly reduced. Furthermore, the temperature of the measuring object in the reactive gas can be measured

more accurately. The needs for temperature measurement in a wide variety of gases will increase in the future at not only semiconductor market but also other markets. As we are developing and producing infrared filters and thermopile sensors in-house, we believe that we can propose more valuable solutions that can meet new market needs.

* This content is based on our investigation at the year of issue unless otherwise stated.

References

- [1] *Readout*, 43, 70(2014)



FUJINO Sho

Custom Instruments R&D Department, Product R&D Center 2
Research & Development Division
HORIBA, Ltd.

HORIBA World-Wide Network

JAPAN

HORIBA, Ltd.

2, Miyano Higashi-cho, Kisshoin, Minami-ku, Kyoto, 601-8510, Japan
Phone : (81)75-313-8121 Fax : (81)75-321-8312

Biwako Factory

1-15-1, Noka, Otsu, Shiga, 520-0102, Japan
Phone : (81) 77-548-6130 Fax : (81) 77-548-6193

HORIBA Advanced Techno Co., Ltd.

31, Miyanoishi-cho, Kisshoin, Minami-ku, Kyoto, 601-8306, Japan
Phone : (81)75-321-7184 Fax : (81)75-321-7291

HORIBA STEC, Co., Ltd.

11-5, Hokodate-cho, Kamitoba, Minami-ku, Kyoto, 601-8116, Japan
Phone : (81)75-693-2300 Fax : (81)75-693-2350

Aso Factory

Torikokogyodanchi, 358-11, Koumaibata, Toriko, Nishihara-mura, Aso-gun, Kumamoto, 861-240, Japan
Phone : (81)96-279-2921 Fax : (81)96-279-3364

Fukuchiyama Technology Center

11-1 Miwa-cho Miwa, Fukuchiyama, Kyoto, 620-1445, Japan
Phone : (81) 773-59-2070 Fax : (81) 773-59-2074

HORIBA TECHNO SERVICE Co., Ltd.

2, Miyano Higashi-cho, Kisshoin, Minami-ku, Kyoto, 601-8305, Japan
Phone : (81)75-313-8125 Fax : (81)75-321-5647

BRAZIL

HORIBA Brasil Holding, Eireli

Rua Presbitero Plinio Alves de Souza, 645, parte A, Loteamento Multivias, Jardim Ermida II - Jundiá São Paulo - CEP 13.212-181 Brazil
Phone : (55)11-2923-5400 Fax : (55)11-2923-5490

HORIBA Instruments Brasil, Ltda.

Rua Presbitero Plinio Alves de Souza, 645, Loteamento Multivias, Jardim Ermida II - Jundiá São Paulo - CEP 13.212-181 Brazil
Phone : (55)11-2923-5400 Fax : (55)11-2923-5490

TCA/HORIBA Sistemas de Testes Automotivos Ltda.

Rua Goiás 191 Vila Oriental, Diadema, São Paulo, Brazil CEP 09941-690
Phone : (55)11-4224-0200 Fax : (55)11-4227-3133

CANADA

HORIBA Canada, Inc.

Unit102, 5555 North Service Road Burlington, Ontario, Canada, L7L 5H7
Phone : (1)905-335-0234 Fax : (1)905-331-2362

London Office

347 Consortium Court, London, Ontario, Canada, N6E 2S8
Phone : (1)519-668-6920 Fax : (1)519-668-8437

U.S.A.

HORIBA United States Holding, LLC

HORIBA Americas Holding Incorporated

HORIBA Instruments Incorporated

9755 Research Drive, Irvine, CA 92618, U.S.A.
Phone : (1)949-250-4811 Fax : (1)949-250-0924

Albany Field Office

Suite 104, 58 Clifton Country Road, Clifton Park, NY 12065, U.S.A.
Phone : (1)-518-280-3675

Ann Arbor Office

5900 Hines Drive, Ann Arbor, MI 48108, U.S.A.
Phone : (1)734-213-6555 Fax : (1)734-213-6525

Austin Office

9701 Dessau Road, Suite 605, Austin, TX 78754, U.S.A.
Phone : (1)512-836-9560 Fax : (1)512-836-8054

Chicago, IL Field Office

554 Anderson Drive, Unit A Romeoville, IL 60446, U.S.A.
Phone : (1)815-372-9076

Houston Office

5390 Bay Oaks Drive, Pasadena, TX 77505, U.S.A.
Phone : (1)281-482-4334 Fax : (1)281-674-6058

Novato Field Office

359 Bel Marin Keys Blvd, #18, Novato, CA 94949, U.S.A.

HORIBA New Jersey Optical Spectroscopy Center

20 Knightsbridge Rd, Piscataway, NJ 08854, U.S.A.
Phone : (1)732-494-8660 Fax : (1)732-549-5125

Portland Office

7007 S.W. Cardinal Lane, Suite 185, Portland, OR 97224, U.S.A.
Phone : (1)503-624-9767 Fax : (1)503-968-3236

HORIBA Reno Technology Center

3740 Barron way Reno, Nevada 89511, U.S.A.
Phone : (1)775-358-2332 Fax : (1)775-358-0434

Sunnyvale Office

430 Indio Way, Sunnyvale, CA 94085, U.S.A.
Phone : (1)408-730-4772 Fax : (1)408-730-8975

Troy Office

2890 John R Road, Troy, MI 48083, U.S.A.
Phone : (1)248-689-9000 Fax : (1)248-689-8578

Atlanta Field Office

5871 Glenridge Drive, Suite 475, Atlanta, GA, U.S.A.

AUSTRIA

HORIBA (Austria) GmbH

Kaplanstrass 5, A-3430 Tulln, Austria
Phone : (43)2272-65225 Fax : (43)2272-65225-45

BELGIUM

HORIBA Europe GmbH

Antwerp Branch

Duwijkstraat 17, 2500 Lier, Belgium
Phone : (32)3-281-57-92 Fax : (32)3-230-06-95

CZECH REPUBLIC

HORIBA Czech

Prague Office

Prumyslova 1306/7, CZ-10200, Praha 10, Czech Republic
Phone : (420)246-039-265

Olomouc Factory

Zeleznicni 512/7, 772 00 Olomouc, Czech Republic
Phone : (420)588-118-365, (420)588-118-393
Fax : (420)585-310-725

FRANCE

HORIBA Europe Holding SASU

14 Boulevard Thomas Gobert - CS 45002 - 91120 Palaiseau, France

HORIBA Europe Research Center

14 Boulevard Thomas Gobert - Passage Jobin Yvon CS 45002 - 91120 Palaiseau - France
Phone : (33)1-69-74-72-00 Fax : (33)1-69-31-32-20

HORIBA FRANCE SAS

Longjumeau Office

16-18, rue du Canal, 91165 Longjumeau Cedex, France
Phone : (33)1-69-74-72-00 Fax : (33)1-69-09-07-21

Villeneuve d'Ascq Office

231 rue de Lille, 59650 Villeneuve d'Ascq, France
Phone : (33)3-20-59-18-00 Fax : (33)3-20-59-18-08

HORIBA ABX SAS

Parc Euromédecine, rue du Caducée, BP7290, 34184 Montpellier Cedex 4, France
Phone : 33(0)4-67-14-15-16 Fax : 33(0)4-67-14-15-17

GERMANY

HORIBA Europe GmbH / Oberursel Office

Hans Mess Strasse 6, D-61440 Oberursel, Germany
Phone : (49)6172-1396-0 Fax : (49)6172-1373-85

Darmstadt Office

Landwehrstrasse 55, D-64293, Darmstadt, Germany
Phone : (49)6151-5000-0 Fax : (49)6151-5000-3865

Dresden Office

Hugo-Junckers-Ring 1, 01109 Dresden, Germany
Phone : (49) 351-8896807 Fax : (49)-351-8896808

Hanover Office

Frankenring 14, D-30855 Langenhagen, Germany
Phone : (49)2161-47537-0

Korschenbroich Office

Friedrich-Ebert-Str. 9-11, D-41352 Korschenbroich, Germany
Phone : (49)2175-8978-0 Fax : (49)2175-897850

Leichlingen Office

Julius-Kronenberg-Str. 9, D-42799 Leichlingen, Germany
Phone : (49)2175-8978-0 Fax : (49)2175-897850

Munich Office

Waldmeisterstr. 72-74/Robinienstr. 66, D-80935 Munich, Germany
Phone : (49)89-2444779-0 Fax : (49)89-2444779-10

Potsdam Office

Dennis-Gabor-Str. 2, D-14469 Potsdam, Germany
Phone : (49)3316-4900-70 Fax : (49)3316-4900-74

Stuttgart Office (Boeblingen)

Hanns-Klemm-Str. 56, D-71034 Boeblingen, Germany
Phone : (49)7031-677-9440 Fax : (49)7031-677-9450

Stuttgart Office (Neuhausen)

Zabergaeustr. 3, D-73765 Neuhausen, Germany
Phone : (49)7158-933-800 Fax : (49)7158-933-899

Wolfsburg Office

Klauskamp, Heinenkap II 38444 Wolfsburg, Germany
Phone : (49)5361-38653-16 Fax : (49)5361-38653-24

HORIBA Jobin Yvon GmbH

Neuhofstrasse 9, D. 64625, Bensheim, Germany
Phone : (49)0-62-51-84-750 Fax : (49)0-62-51-84-7520

HORIBA FuelCon GmbH

Steinfeldstraße 1, 39179 Barleben, Germany
Phone : (49)39203-514-400 Fax : (49)39203-514-409

HORIBA Tocadero GmbH

Johann-Hittorf-Str. 8 12489 Berlin Germany
Phone : (49)0-30-6392-3150 Fax : (49)0-30-6392-3151

ITALY

HORIBA ITALIA Srl

Via Luca Gaurico 209, 00143 Roma, Italy
Phone : (39)6-51-59-22-1 Fax : (39)6-51-96-43-34

Torino Office

Via Ferroggio, 30, 10151, Torino, Italy
Phone : (39)1-19-04-0601 Fax : (39)1-19-00-0448

HORIBA ABX SAS

Italy Branch

Viale Luca Gaurico 209/211, 00143 Roma, Italy
Phone : (39)6-51-59-22-1 Fax : (39)6-51-96-43-34

MAURITIUS

MIRA Engineering Service Mauritius Ltd.

9th Floor, Orange Tower, Cybercity, Ebene, Mauritius

NETHERLANDS

HORIBA Europe GmbH

Netherlands Branch

Science Park Eindhoven, 5080 (Industrial park "Ekkersrijt") 5692 EA Son Netherlands
Phone : (31)40-2900240 Fax : (31)40-2900624

POLAND

HORIBA ABX Sp. z o. o.

ul. Putawska 182 02-670 Warszawa, Poland
Phone : (48)22-673-2022 Fax : (48)22-673-2026

PORTUGAL

HORIBA ABX SAS

Portugal Branch

Alfrapark Estrada de Alfragide n° 67, Edificio F - Piso 0 Sul, 2610-008 Amadora, Portugal
Phone : (35)12-14-72-17-70 Fax : (35)12-14-72-17-89

ROMANIA

HORIBA (Austria) GmbH

Romania Branch

B-dul.Republicii, nr. 164, Etaj Parter, Birourile nr. 3 si 4, Pitesti, 110177, Judetul Arges, Romania
Phone : (40)348-807117 Fax : (40)348-807118

RUSSIA

HORIBA OOO

Altufievskoe shosse, 13, building 5, 127106, Moscow, Russia
Phone : (7)495-221-87-71 Fax : (7)495-221-87-68

Zelenograd Office

Office 106, 2nd West st., 1, build 1, 124460, Zelenograd city, Moscow, Russia
Phone : (7)499-995-09-54

SPAIN

HORIBA MIRA SPAIN, S.L.

Calle Oficios, nave 22, 04620 Vera (Almeria), Spain
Phone : (34)-950-39-11-53

HORIBA ABX SAS

Spain Branch

Calle Apolonio Morales. Num.6(Bajos), 28036 Madrid, Spain
Phone : (34)91-353-30-10 Fax : (34)91-353-30-11

SWEDEN

HORIBA Europe GmbH

Sweden Branch (Goteborg)

Grimboasen 10 A, S-417 49 Gothenburg, Sweden
Phone : (46)10-161 1500 Fax : (46)10-161 1503

Sweden Branch (Sodertalje)

Sydhamnsvagen 55-57, SE- 15138 Sodertalje, Sweden
Phone : (46)8-550-80701 Fax : (46)8-550-80567

TURKEY

HORIBA Europe GmbH

Istanbul Office

Küçükbakkalköy Mah. Kayışdağı Cad., Flora Residence No:3/2504, 34750 Ataşehir/Istanbul, Turkey
Phone : (90)216-572-1166 Fax : (90)216-572-1167

HORIBA World-Wide Network

United Kingdom

HORIBA UK Limited

HORIBA UK Finance Limited

Kyoto Close, Moulton Park, Northampton, NN3 6FL, United Kingdom

Phone : 44(0)1604 542500 Fax : 44(0)1604 542699

HORIBA Jobin Yvon IBH Ltd.

133 Finnieston St. Glasgow G3 8HB, United Kingdom

Phone : (44)141-229-67-89 Fax : (44)141-229-67-90

HORIBA Test Automation Ltd.

Brook Court, Whittington Hall, Worcester WR5 2RX, United Kingdom

Phone : (44)1905-359359 Fax : (44)1905-359332

HORIBA MIRA Limited

HORIBA MIRA Certification Limited

MIRA Int'l Limited

MIRA Land Limited

MIRA Service Limited

MIRA Technology Park Limited

Watling Street, Nuneaton, Warwickshire, CV10 0TU, United Kingdom

Phone : (44)24-7635-5000

HORIBA MIRA Limited

Quatro Park

Unit 1, Quatro Park, Paycocke Road, Basildon, Essex, SS14 3GH, United Kingdom

Phone : (44) 1268-290100

CHINA

HORIBA INSTRUMENTS (SHANGHAI) Co., Ltd.

No.200, Taitao Road, Anting Town, Jiading District, Shanghai, 201814, China

Phone : (86)21-6952-2835 Fax : (86)21-6952-2823

HORIBA Precision Instruments (Beijing) Co., Ltd.

Chaoyang District, Bei Yuan Road 40, Beijing, 100012 China

Phone : (86)10-8492-9402 Fax : (86)0-8492-7216

HORIBA Technology (Suzhou) CO.,LTD.

No.1 building, Industry park, No.101 Chenmenjing Rd, Taicang, Jiangsu, China (215400)

HORIBA (China) Co., Ltd.

Room 1604, Building 1, No.185 Moyu Road, Anting Town, Jiading District, Shanghai, China, 201805

Phone : (86)21-6289-6060 Fax : (86)21-6289-5553

HORIBA (China) Trading Co., Ltd.

Unit D, 1 Floor, Building A, Synnex International Park, 1068 West Tianshan Road, Shanghai, 200335, China

Phone : (86)21-6289-6060 Fax : (86)21-6289-5553

Beijing Branch

12F, Metropolis Tower, No. 2, Haidian Dong 3 street Beijing 100080, China

Phone : (86)10-8567-9966 Fax : (86)10-8567-9066

Guangzhou Branch

Room 1611/1612, Goldlion Digital Network Center, 138 Tiyu Road East, Guangzhou 510620, China

Phone : (86)20-3878-1883 Fax : (86)20-3878-1810

Shanghai Service Center

Room 303, No.84, Lane887, Zu-Chong-Zhi Road, Zhangjiang Hi-tech Park, Shanghai, 201203, China

Phone : (86)21-5131-7150 Fax : (86)21-5131-7660

Shanghai Technical Center

No.200, Taitao Road, Anting Town, Jiading District, Shanghai, 201814, China

Phone : (86)21-6289-6060 Fax : (86)21-6289-5553

MIRA China Ltd.

BSuite 501, Block B, Hongqiao Sunnyworld

No. 1226 South Shenbin Road

Shanghai, 201106, China

Phone : (86)21-6220-6377 Fax : (86)21-6220-6379

INDIA

HORIBA India Private Ltd.

246, Okhla Industrial Estate, Phase 3, New Delhi, 110020, India

Phone : (91)11-4646-5000 Fax : (91)11-4646-5020

Bangalore Office

No.55,12th Main, Behind BDA Complex, 6th sector, HSR Layout, Bangalore South, Bangalore-560102, India

Phone: (91)80-4127-3637

Chennai Office

No.9, 01&02 Floor, Ganapathy Colony, Thiru-Vi-Ka Industrial Estate, Guindy, Chennai, 600032, India

Phone : (91)44-42077899

Kolkata Office

EK Tower/6th Floor/Office-4A, Action Area-IID, Newtown, Pin Code 700161, India

Haridwar Factory

Plot No. 26, Sector-7, IIE, SIDCUL, Haridwar, Uttarakhand - 249403, India

Phone : (91)1334-239139

Technical Center

D-225, Chakan MIDC Phase-II, Bhamboli Village, Pune-410501, India

Phone : (91)02135-676000

INDONESIA

PT HORIBA Indonesia

JL. Jalur Sutera Blok 20A, No. 16-17, Kel. Kunciran, Kec. Pinang Tangerang 15144, Indonesia

Phone : (62)21-3044-8525 Fax : (62)21-3044-8521

KOREA

HORIBA KOREA Ltd.

25, 94-Gil, Ilijik-Ro, Manan-Gu, Anyang-Si, Gyeonggi-Do, 13901, Korea

Phone : (82)31-296-7911 Fax : (82)31-296-7913

Ulsan Office

613, Doosan We've the Zenith, 1877, Sinjeong-Dong, Nam-Gu, Ulsan-Si, 44679, Korea

Phone : (82)52-275-0122 Fax : (82)52-276-0136

HORIBA STEC KOREA, Ltd.

98, Digital valley-ro Suji-gu, Yongin-si Gyeonggi-do 16878, Korea

Phone : (82)31-8025-6500 Fax : (82)31-8025-6599

HORIBA MIRA, Ltd.

Korea Branch Office

25, 94-Gil, Ilijik-Ro, Manan-Gu, Anyang-Si, Gyeonggi-Do, 13901, Korea

Phone : (82)70-4689-0680 Fax : (82)31-296-7913

PHILIPPINE

HORIBA INSTRUMENTS (SINGAPORE) PTE LTD.,

MANILA Office

27/F Tower 2, Enterprise Center 6766, Ayala Avenue cor Paseo de Roxas, Makati City, Philippines, 1226

Phone : (63)2-8885-8468

SINGAPORE

HORIBA Instruments (Singapore) Pte. Ltd.

3 Changi Business Park Vista #01-01, Singapore, 486051

Phone : (65)6-745-8300 Fax : (65)6-745-8155

West Office

83 Science Park Drive #02-02A, The Curie, Singapore 118258

Phone : (65)6-908-9660

TAIWAN

HORIBA Taiwan, Inc.

8F.-8, No.38, Taiyuan St. Zhubei City, Hsinchu County 30265, Taiwan (R.O.C.)

Phone : (886)3-5600606 Fax : (886)3-5600550

Tainan Office

1F., No.117, Chenggong Rd, Shanhua, Township, Tainan Country 741, Taiwan (R.O.C.)

Phone : (886)6-583-4592 Fax : (886)6-583-2409

THAILAND

HORIBA Holding (Thailand) Limited

393 395 397 399 401 403 Latya Road, SomdetChaophraya, Klongsan, Bangkok 10600, Thailand

Phone : (66)2-861-5995 Fax : (66)2-861-5200

HORIBA (Thailand) Limited

393 395 397 399 401 403 Lad Ya Road, Somdetchaophraya, Klongsan District, Bangkok 10600, Thailand

Phone : (66)2-861-5995 ext.123 Fax : (66)2-861-5200

East Office

850/7 Soi Lat Krabang 30/5, Lat Krabang Road, Lat Krabang, Bangkok 10520, Thailand

Phone : (66)0-2-734-4434 Fax : (66)0-2-734-4438

VIETNAM

HORIBA Vietnam Company Ltd.

Lot 3 and 4, 16 Floor, Detech Tower II, No.107 Nguyen Phong Sac Street, Dich Vong Hau Ward, Cau Giay District, Hanoi, Vietnam

Phone : (84)-24-3795-8552 Fax : (84)-24-3795-8553

Ho Chi Minh Branch Office

Room 8.6-8th Floor, Le Meridien Building, 3c Ton Duc Thang Street, Ben Nghe ward, District 1, Ho Chi Minh City, Vietnam

Phone : (84)28-7305-4492 Fax : (84)28-6287-6269

* This content is based on our investigation at the year of issue unless otherwise stated.

Readout HORIBA Technical Reports English Edition No.54

Publication Date : July 10th, 2020
Publisher : HORIBA, Ltd.
Editor : NISHIKATA Kentaro
Associate Editor : NOMURA Satoshi, NAKATANI Shigeru
Andrew WHITLEY, Marcus RIEKER, Florian FORMANEK
Publication Members : NAKATA Yasushi, URAKAMI Chikako, SAKAMOTO Junichi,
OHTAKE Yoshihiro, MATSUDA Tetsuya, SATAKE Hiromi
DTP, Printing : SHASHIN KAGAKU Co., Ltd.
Information : R&D Planning Center, Research & Development Division, HORIBA, Ltd.
2, Miyanohigashi-cho, Kisshoin, Minami-ku, Kyoto 601-8510, Japan
Phone : (81)75-313-8121
E-mail : readout@horiba.co.jp
URL : <https://www.horiba.com/us/en/publications/readout/>