

Product Introduction

Development of the Ambient Carbon Dioxide Monitor APCA-370

NAGASAWA Kenya

MIZUNO Yusuke

In recent years, there has been an increasing need to measure carbon dioxide (CO₂) in our atmosphere with high accuracy. This is due to the necessity of measuring, controlling, and reducing the emissions of the greenhouse gas, CO₂, in each country participating in the Paris Agreement. The HORIBA APCA-370 is a device that measures carbon dioxide in the atmosphere with high accuracy. This has been achieved by adopting our unique measurement technology method, cross flow modulation, and a self-regenerating CO₂ purifier. This paper introduces the development history and features of the APCA-370 in detail.

Introduction

Reduction of greenhouse gases emissions - CO₂, nitrous oxide, methane, and others - is one of the goals for the Paris Agreement adopted in 2015. The monitoring of CO₂ concentration in our atmosphere has been attracting attention, and the requirements for monitoring CO₂ has been increasing year over year, especially in Europe.

Since the early 1960s, many countries have been measuring CO₂ in areas with low anthropogenic emissions (abbreviated as background CO₂ monitoring). This is led by the WMO (World Meteorological Organization) to clarify long-term global changes in atmospheric components that effect weather and climate. In Japan, the Japan Meteorological Agency has released data collected from Ryori Village (Iwate Prefecture), Minamitori Island (Ogasawara Village, Tokyo), and Yonaguni Island (Okinawa Prefecture). Recent measurements of CO₂ concentration have exceeded 400 ppm. This concentration increased by 47% compared with the average value of 278 ppm before the Industrial Revolution (around 1750).^[1]

Technologies for capturing and effectively utilizing emitted CO₂ have been developed and have been a key to minimizing CO₂ emissions. Highly sensitive measurement of CO₂ is essential for detecting the leakage of captured CO₂. A device that measures CO₂ with high sensitivity, high accuracy, and long-term stability is required for the background CO₂ monitoring and the leakage of captured CO₂. The HORIBA APCA-370 was developed to satisfy these requirements.

Product Overview

Generally, when a molecule composed of two or more different atoms is irradiated with infrared light, the molecule will absorb the infrared light with specific wavelength based on the energy levels of vibration and rotational motion of the molecule. Non-dispersive infrared absorption (NDIR) performs quantitative analysis by measuring the amount of specific wavelength absorption of a molecule. The change in the amount of infrared absorption depends on the concentration of the absorbing molecule (the measuring gas). This relationship is expressed by the Lambert-Beer law of Equation 1.

$$I = I_0 \exp(-mcd) \dots \dots \dots (1)$$

- I₀ : Intensity of incident light
- I : Intensity of transmitted light
- c : Concentration of absorbing molecule (measuring gas)
- m: absorption coefficient (constant determined by molecule and wavelength)
- d : Thickness of absorption molecular layer (gas layer)

Since I₀, μ and d are constants that can be determined by the type of measuring gas component and the device, the concentration of measuring gas, c, can be determined by measuring the intensity of transmitted light, I. For the measurement of CO₂, the NDIR method is widely used because CO₂ has strong absorption in the infrared region. NDIR is simple in structure, easy to maintain, and suitable for continuous measurement.^[2]

Double beam type NDIR has been used in our measurement of CO₂. Figure 1 shows the schematic diagram of a

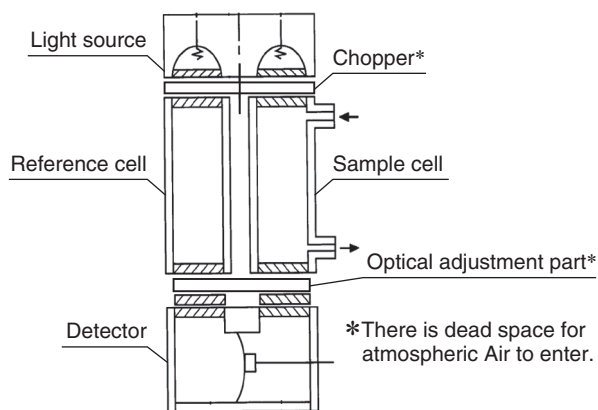

Figure 1 Schematic diagram of a double beam type NDIR

double beam type NDIR. The infrared light emitted from the light source passes through the sample cell and the reference cell and enters the detector. The transmitted light in the sample cell and reference cell enter the detector alternately via the splitting of infrared light by a continuously rotating optical chopper. The amount of infrared light entering the sample cell and the reference cell is adjusted to be substantially equal in the optical adjustment part. The intensity of the transmitted light that passes through the sample cell will decrease as the result of the proportion of absorption of infrared light to CO₂ concentration present. The intensity of transmitted light passing through the reference cell will remain unchanged due to the presence of a sealed gas that does not absorb infrared light. The difference in the transmitted light is detected by the detector and converted into an electric signal.^[3]

There are two issues in this method when monitoring background CO₂ or detecting leakage of recovered CO₂ with high sensitivity, high accuracy, and long-term stability. The first issue is the effect of change in CO₂ concentration in the dead space. The optical system has some dead space in the structure of the chopper and the light adjustment part. Ambient air containing CO₂ can infiltrate the space. It is possible that when humans are present and exhaling CO₂, the CO₂ concentration in the space is changed, and this change can effect the reading value. This effect is a non-negligible error for highly sensitive measurements of CO₂. Therefore, the dead space must be purged for the CO₂ concentration remains constant, or the optical system must have a structure in which CO₂ does not enter. The second issue is drift. The output at zero reading will drift slightly over time. This is called zero-drift. Successive changes in the reflectance of the sample cell surface and the transmittance of the window both cause zero-drift. This drift brings about a non-negligible error during the measurement of low amounts of CO₂, such as the leakage of the recovered CO₂ described in introduction. Thus, it is necessary to calibrate the mea-

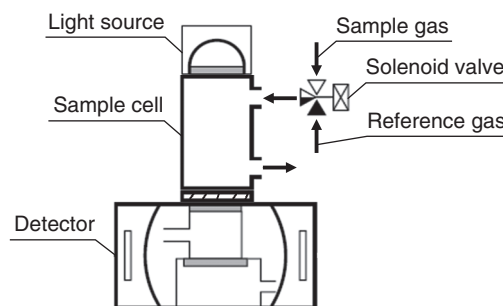

Figure 2 Schematic diagram of a cross-flow modulation type NDIR

surement system more frequently than usual.

To solve this issue, the APCA-370 adopts HORIBA's unique fluid modulation method (cross-flow modulation). Figure 2 shows the basic structure and operating principle. The APCA-370 consists of a light source, a cell, a detector, and a flow modulator (solenoid valve). In an infrared analyzer using the cross-flow modulation method, fixed amounts of sample gas and reference gas that does not contain CO₂ are alternately introduced into the sample cell by solenoid valve, and an alternating current is produced as a signal as a result of the two gases different absorption strengths. Therefore, the cross-flow modulation without optical chopper part and light adjustment part is designed to minimize the dead space. The change of the condition of the cell window surface and reflectivity of the cell inner wall surface over certain periods can



Figure 3 External Appearance of the APCA-370

Table 1 Specification of APCA-370

Measurement principle	NDIR	
Measurement target	Carbon dioxide (CO ₂) in ambient air	
Range	0 to 500/1000 ppm	
Lower detectable limit	0.5 ppm (2σ)	
Reproducibility (repeating accuracy)	± 1.0% of the full scale	
Linearity (readout error)	± 2.0 % of the full scale	
Zero drift	± 1.0 ppm/day	
Span drift	± 2.0 % of the full scale/day	
Response time	60 sec or shoter (T ₉₀ from the inlet)	
Gas flow rate	Approximately 0.7 L/min	
External dimensions	(W)	430 mm
	(H)	221 mm
	(D)	550 mm
mass	Approximately 20 kg	

be canceled by supplying a sample gas and reference gas to only one cell when detecting gas concentration. Cross-flow modulation has very low zero-drift.^[3,4] The external appearance and main specifications of the APCA-370 system are shown in Figure 3 and Table 1.

Adoption of Self-regenerating CO₂ purifier

What is important in adopting the cross flow modulation method is the CO₂ content contained in the reference gas. As described above, in the cross-flow modulation method, the measured value is the difference in the concentration of CO₂ between the sample gas and the reference gas. Therefore, the amount of CO₂ contained in the reference gas is one of the measurement errors. There are two methods for supplying reference gas. These are by using a gas cylinder without CO₂ or removing CO₂ from the atmosphere or sample gas with the adsorbent and purifying it to the reference gas. The gas cylinder needs to be changed frequently as the cross-flow modulation requires large amounts of reference gas. Frequent replacement of gas cylinders increases the burden on the user.

Soda lime is used to purify CO₂. Regeneration is difficult and the adsorbent must be replaced periodically. This makes maintenance relatively complicated, but not as much as replacing the gas cylinder. Therefore, the APCA-370 adopts an adsorbent that has a high adsorption performance for CO₂, and desorbs CO₂ when the temperature is increased. The APCA-370 has two purifiers packed with adsorbent. One is performing reference gas purification, while the other is performing regeneration with increasing temperature. Purification and regeneration operations are performed alternately, and a reference gas is always introduced into the sample cell to enable continuous measurement.

A uniqueness to minimize consumption of adsorbents in the purifier.

APCA-370 reuses the reference gas as a purification gas in its gas flow system as shown in Figure 4, and therefore it enables to reduce consumption of adsorbents in the purifier. The sample gas (Q1) is introduced from the sample inlet and flows into the sample cell by passing through the solenoid valve. The gas is then introduced to the purifier (Q2). Some of the gas are used as a reference gas returning to the sample cell without CO₂ (Q3), and the rest of the gas is for a purification gas to regenerate ability of adsorption in the purifier (Q4). The returning reference gas (Q3) flows into the sample cell and comes back to the purifier again. Hence, the types of gas introduced into the purifier during the operation are followings: sample gas with CO₂ and reference gas without CO₂. As a result, total

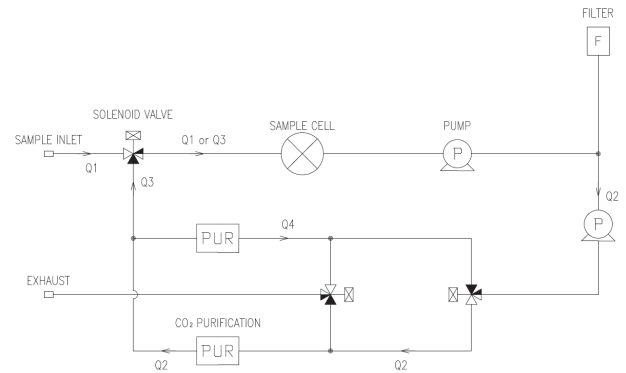

Figure 4 Schematic diagram of APCA-370 gas flow

consumption of adsorbents in the purifier is significantly reduced, compared with the system in which the sample gas with CO₂ keeps coming into the purifier. APCA-370 is able to reduce consumption of adsorbents down to 40% from conventional gas flow systems.

Verification test

A demonstration test of APCA-370 was conducted from May 24, 2019 to December 6, 2019 at an air quality monitoring station (AQMS) in our factory. AQMS is shown in Figure 5. The device periodically introduces 0 ppm gas without calibration, and the results are shown in Figure 6. Zero-drift was about 0.1 ppm at the maximum in six months, and the drift amount was below the Lower detectable limit. These results indicate that APCA-370



Figure 5 Air Quality Monitoring Station (AQMS)

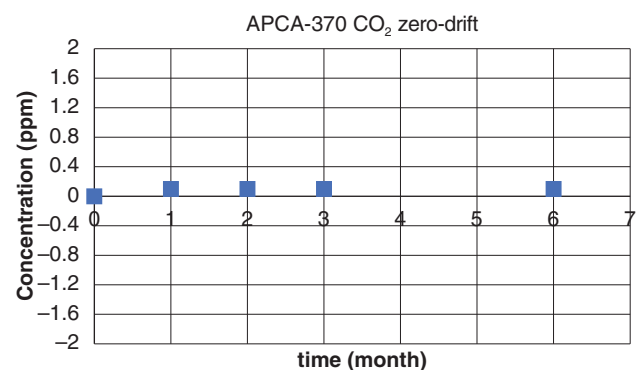

Figure 6 The result of zero-drift

has low zero-drift and can perform long-term stable measurement.

Conclusion

At present, with the increasing public interest in environmental issues, highly accurate and highly reliable atmospheric measurement devices are required. The APCA-370 introduced here is expected to be applied not only to background CO₂ monitoring but also to various fields such as indoor CO₂ monitoring for which demand will increase in the near future. Our mission as a comprehensive manufacture of analytical instrument, is to improve the APCA-370 actively develop domestic and overseas markets, meet customer and contribute to society.

* Editorial note: This content is based on HORIBA's investigation at the year of issue unless otherwise stated.

References

- [1] “二酸化炭素濃度の経年変化” 気象庁. 2020-01-21.
 (“change over the years of carbon dioxide” Japan Meteorological Agency. 2020-01-21)
https://ds.data.jma.go.jp/ghg/kanshi/ghgp/co2_trend.html,
(accessed 2020-02-26)
- [2] Junji AOKI, Pneumatic Infrared Detector, *Readout*, **7**, 64-71(1993).
- [3] Kazunori MIZUMOTO, Development of the Multi-Component Gas Analyzer VA-5000 Series, *Readout*, **51**, (2018)
- [4] Takao IMAKI, Monitoring System for atmospheric CO₂, *Readout*, **1**, 33-39(1990)



NAGASAWA Kenya

Process & Environmental Instruments R&D Dept.
Research & Development Division
HORIBA, Ltd.



MIZUNO Yusuke

Deputy Dept. Manager
Process & Environmental Instruments R&D Dept.
Research & Development Division
HORIBA, Ltd.