

Product Introduction

Sulfur in Oil Analyzer SLFA-60

Sumito OHZAWA

The SO_x in motor exhaust leading to air pollution is restricted, and a regulation value is becoming severe every year. In order to sufficient performance of the emission gas processing unit especially, reduction of sulfur content in fuel is indispensable. On the other hand, as for the crude oil used as the materials of fuel, there is much sulfur content with high viscosity oil and shale oil are also mined. Management of the sulfur content in a materials stage is important. Sulfur in oil analyzer SLFA-60 is the equipment which targeted management of the sulfur content in a materials stage. The printed circuit board and software were renewed in order to correspond to many kinds of oil.

Introduction

SO_x in automotive exhaust comes from the combustion of sulfur materials in fuel. These compounds contribute to general air pollution and are a major contributor to acid rain. They also degrade the performance of the catalytic converters which are designed to protect the environment. As a result the permitted levels of sulfur continue to decrease over time.

In the United States, both gasoline and diesel fuel levels have been adjusted several times. For gasoline, in 1995 it was reduced from 300 PPM to 30 PPM. In 2017 it will again be reduced, this time to 10 PPM to conform to Tier III Gasoline Regulations. Diesel fuel was reduced to 500 PPM in 1993 for low sulfur diesel and then to 15 PPM in 2006 for ultra-low sulfur diesel. It is expected to also go to 10 PPM in the not too distant future.

In the European Union (EU) fuel regulations were tightened in going from Euro-1 Rules to the Euro-5 Rules. In 2005 the sulfur content of both gasoline and diesel fuel was reduced to 50 PPM. This was followed by further reduction to 10 PPM in 2010. It is anticipated that new fuel sources will be included in these regulations in the near future.

In parallel, the sources for these fuels have been changing dramatically. New sources such as very sour, heavy crude oils, as well as shale oil from the fracking process,

continue to be more completely exploited. These new feedstocks for the distillation process must be properly treated to assure the quality of the fuel products. This changing scenario presents some real challenges for refiners of these materials.

Overview of the SLFA-60

Principles of measurement

The SLFA-60 is an X-ray Fluorescent analyzer which can measure the sulfur content of a variety of matrices including oil. This device conforms to K2541-4, "Crude oil and petroleum products – Determination of sulfur content Part 4; Energy-dispersive X-ray fluorescence method." It is also compliant with ASTM D4294-10, "Standard Test Method for Sulfur in Petroleum and Petroleum Products by Energy Dispersive X-ray

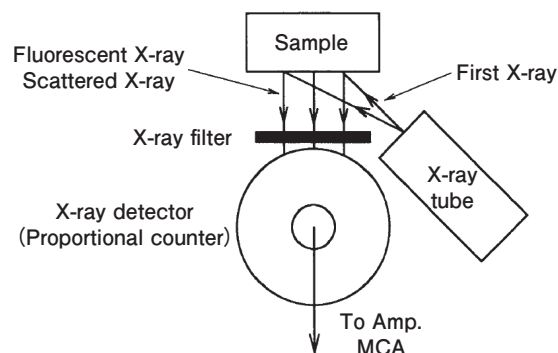

Figure 1 Scheme of measurement

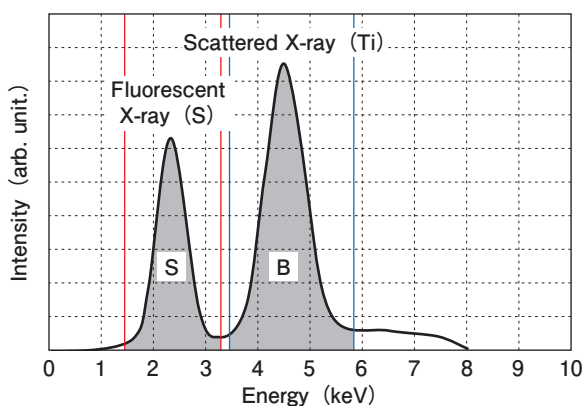

Figure 2 A view of an energy spectrum

Fluorescence Spectrometry in the Americas. It is also covered by ISO 20847:2004”, Petroleum Products – Determination of sulfur content of low sulfur automotive fuels – Energy-dispersive X-ray fluorescence spectrometry in Europe.

As is shown in Figure 1, the exciting X-rays are generated by an X-ray tube and are referred to as the primary X-ray beam. These X-rays are focused directly on the sample material located in the sample cup. Most of this X-ray beam is simply scattered by the matrix surrounding the sample in the cup. This energy from the primary X-rays and the scattered X-rays have an energy very close to 4.5 keV. This energy is characteristic of titanium which is the anode material in the X-ray tube. Some of the primary X-rays do strike the sulfur atoms which are present in the matrix. This interaction generates fluoresced X-rays at 2.3 keV which are those characteristic of sulfur. If a constant flux of primary X-rays hit the sample, the number of fluoresced X-rays at 2.3 keV will be constant and will be proportional to the sulfur concentration. The only exception to this relationship is at high (>0.02 wt %) where self-absorption becomes an issue unless proper calibrations are performed.

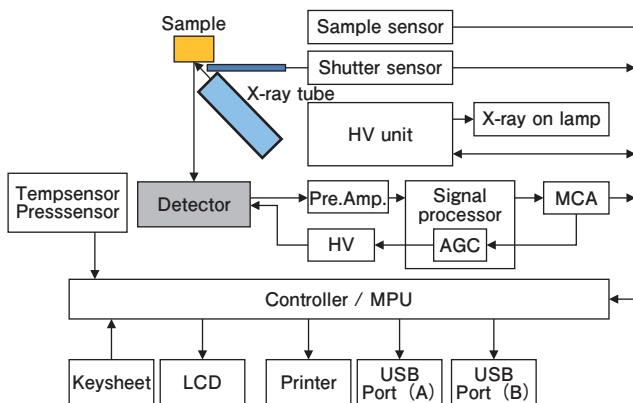

Figure 3 Block diagram of SLFA-60

Both the scattered and fluoresced X-rays exit the sample cup together and encounter an Nb filter which is designed to remove the fluoresced X-rays from interfering elements. After the X-rays of interest pass through this foil, they should be nearly the only X-rays which enter the Proportional-Counter. In this detector, electric charges are generated which are proportional to the energies of the impinging X-rays. These individual charges are then converted into voltage signals in the pre-amp. These signals are converted into an energy spectrum in the multi-channel pulse-height analyzer using a spectrum processing circuit. Figure 2 shows a typical energy spectrum coming from the SLFA-60 detection system.

The data shown can be used to measure the sulfur concentration by determining the area under the sulfur peak. By preparing solutions of varying sulfur concentrations and plotting these areas versus concentration, a calibration curve can be derived. This allows unknown samples to be measured and the area to be used to determine the concentration. By examining the scattered peak in the sample in relationship to this peak in the calibrant, matrix corrections can be applied to correct the sulfur determination for this effect.

Configuration of the SLFA-60

The block diagram of the SLFA-60 is shown in Figure 3. The external appearance of the instrument is shown in Figure 4.

Unique features of the SLFA-60

- The signal processing is completely digital including a high-speed data sampling circuit. This provides significant reduction in the size and weight of the instrument.
- The automatic calibration selection feature has been increased to three. This eliminates the need to manually change calibration curves as the sample type varies..



Figure 4 Appearance of SLFA-60

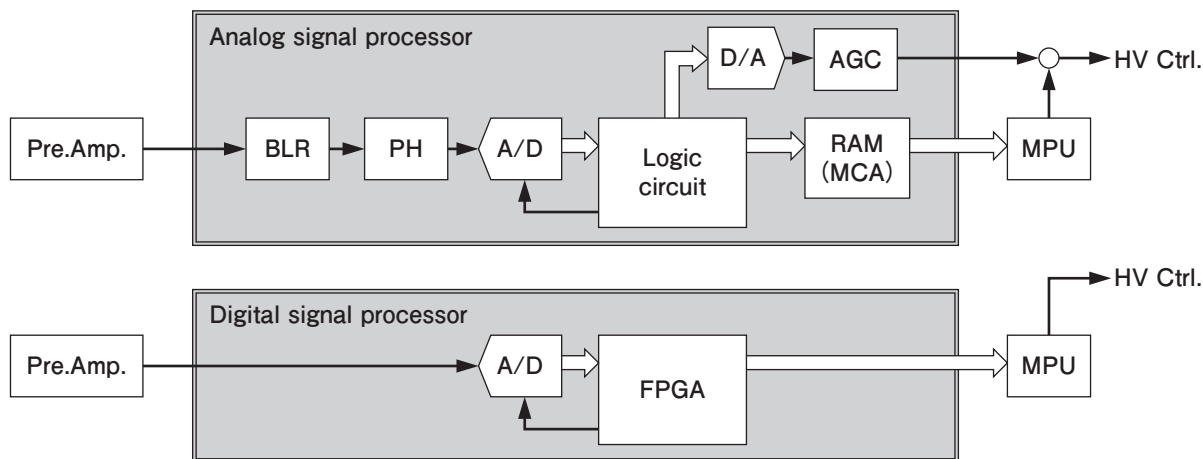

Figure 5 Comparison of analog-signal-processing and digital-signal-processing

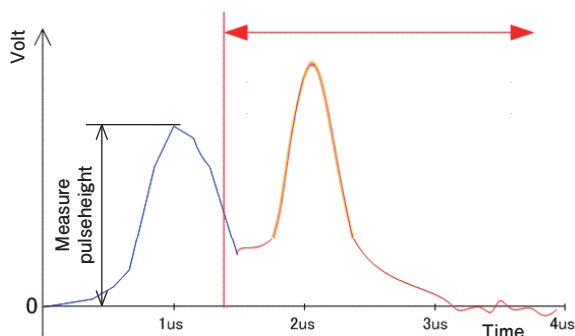
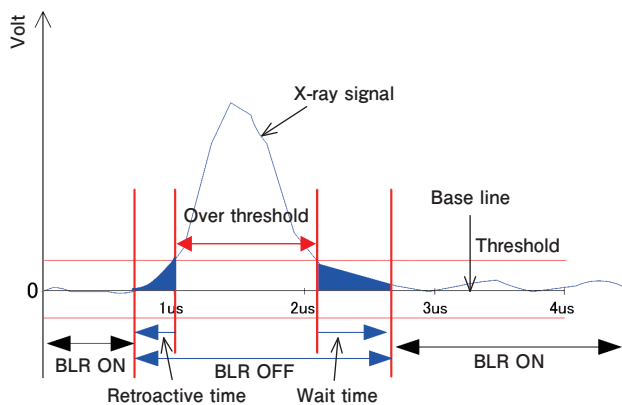
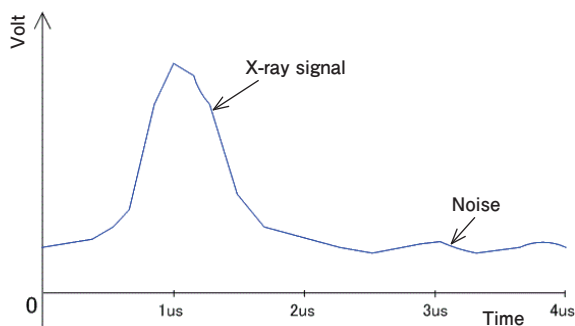

Figure 6 Schematic diagram of the signal processing procedure

- The sample measurement range has been expanded from 5 to 10 wt% to accommodate high-sulfur crude oils.
- The SLFA-60 design is based on HORIBA's renowned industrial design which features many curved surfaces.
- Instrumental results are made easier to read with the larger, colored LCD.
- New USB interface makes data transfer very easy. This can be used for connection to a PC or a thumb drive.
- Compliant with the new cabinet X-ray systems, EN61010-2-091.

Digital Signal Processing

Figure 5 compares analog signal processing to the newer digital signal processing. The bottom drawing illustrates the much simpler design of the new electronics.

Electronic Signal Conditioning

The next four signal processing procedures were all made possible by the digital design. They are illustrated sequentially in Figure 6.

Base line correction (BLC)

This is a process to remove the noise component in the spectra originating from the pre-amplifier. This process is composed of the following two steps. In the first step, the signal baseline is adjusted to approximately the zero level and the threshold for the baseline is set. When a signal exceeds the threshold for a constant period of time, the signal baseline is readjusted to the zero level. (The time scales are defined differently for the baseline and the peak detection).

In the second step, the remaining noise component is subtracted from the X-ray signal from sulfur. When the X-ray signal reaches the detector, the signal voltage exceeds the threshold level, and it recedes below the threshold level after several micro seconds. The total time for the signal collection is the time when the signal exceeded the threshold. The noise component and the X-ray signal are separable by subtracting the retroactive time and the wait time from the sulfur peak.

X-ray pulse detection

The signal detection for the X-ray is set at the high and low end of the time scale. Signal arriving before or after that time window is considered to be noise and so not counted.

Pulse height detection (PH)

The maximum signal intensity for the X-ray is established. The multi-channel analyzer remembers that value. After that, no further counting will occur until a signal of this magnitude is detected. During this “dead time” no further counting will take place.

Automatic gain control (AGC)

This is a method used to control the counting which must occur as the spectrum is shifting. As proportional counters age, the count rate will fluctuate due to changes in composition of the internal gas inside the detector. Ambient conditions as well as the aging of electronic components can also cause the spectrum to shift. When the sulfur peak shifts it can cause peaks to be missed during the counting procedure. By constantly identifying the maximum channel in the peak, the sulfur X-rays are always properly counted.

SLFA-60 Specifications

With the SLFA-60, as with other analytical instruments,

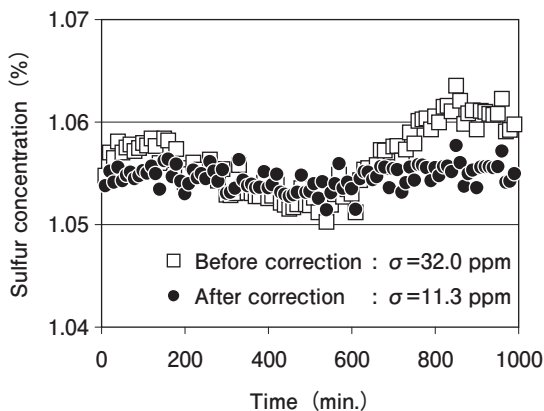

Figure 7 Changes of temperature and atmospheric pressure

the key criteria is repeatability (σ). This statistical parameter is determined from repeat measurements of the same sample. This parameter is comprised of a series of errors which are defined below.

The SLFA series is detecting sulfur fluoresced X-rays.

In this sort of measurement, the response is known to follow a Poisson distribution. In this case the standard deviation of the counts, N , is known to equal \sqrt{N} . In order to overcome this limitation the SLFA-60 does not utilize the count of the sulfur fluoresced X-rays. Instead, the K-value, which is the ratio of the sulfur X-rays to the scattered titanium X-rays, is used to determine sulfur concentration. The statistical error, which is the main contributor to the standard deviation, is obtained by multiplying the standard deviation of the K-Value by the slope of the calibration curve. This results in a smaller number and so a better standard deviation. This is shown in the equations below. The calculation of the statistic error is shown below.

X-ray count rate of sulfur : NS

X-ray count rate of sulfur : NB

Measurement time for the sample : t

Slope of the calibration curve : a

Standard deviation of sulfur counting rate σ_s is,

$$\sigma_s = \sqrt{(NS \times t) / t}$$

Standard deviation of titanium counting rate σ_B is,

$$\sigma_B = \sqrt{(NB \times t) / t}$$

Because $K = NS / NB$, the standard deviation of K value is,

$$\sigma_K = \sqrt{((\sigma_s / NB)^2 + (NS \times \sigma_B / NB^2)^2)}$$

Then by multiplying the slope of the calibration curve, the statistic error is,

$$\text{Statistic error} = a * \sigma_K$$

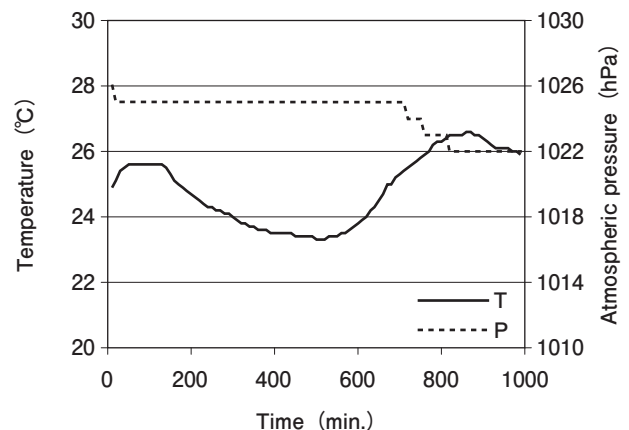

Figure 8 Results of repeated measurement

Changes in temperature or atmospheric pressure

The count rate for sulfur and titanium will be varying due to changes in ambient conditions. These changes caused by the changing performance of the X-ray source and detector must be corrected by the instrument. In order to do this correction the SLFA-60 is equipped with temperature and pressure sensing capabilities.

Evaluation of repeatability

Evaluation conditions:

Sample : Crude oil containing 1% sulfur

Measurement time : 600 second

Number of repetition : 99

Figure 8 shows uncorrected and corrected data for a 1.0 wt% sample of crude oil run on the SLFA-60. The swings in temperature and pressure which resulted in this unstable data are illustrated in Figure 7. The solid dots in Figure 8 illustrate the improved standard deviation after the correction has been applied.

X-ray counting rate of sulfur : NS = 4.9 kcps

X-ray counting rate of titanium : NB = 8.8 kcps

Measurement time : t = 600 second

Slope of the calibration curve : a = 2.251

⇒ Statistic error : 9.1 ppm

The uncorrected data had as standard deviation of 320 ppm while the corrected was 11.3 ppm.

Conclusion

This paper provides a brief introduction to the main features of the SLFA-60. The SLFA-60 provides the same accuracy and repeatability as its predecessor, but features many benefits of using digital electronics. This reduces the size and weight of the electronics as well as simplifying its use. This latest addition to the SLFA-60 line-up will greatly enhance the product line. It will also serve as a springboard for future developments of this product line-up.

References

- [1] Oil Hand Book: JX Nippon Oil & Energy
- [2] Yoshiaki Okada, *Readout(HORIBA Technical Report)*, 5, 43(1992)

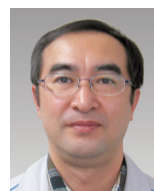

Sumito OHZAWA

Scientific & Semiconductor Instruments R&D Dept.
Application R&D Center
Research & Development Division
HORIBA, Ltd.