

Introduction of HORIBA FuelCon GmbH Evaluation Technologies for Battery and Fuel Cell

HORIBA FuelCon社の紹介

バッテリーと燃料電池の評価技術

2050年までにCO₂(二酸化炭素)排出量を大幅削減するための国家や社会の動きやエネルギーセキュリティを背景に、自動車のエネルギー効率の飛躍的な向上や、太陽光や風力など再生可能エネルギーによる発電が再び着目されています。今、自動車産業は市場、技術、規制など多次元の変化を目の当たりにしています。電動車両の普及により将来全ての自動車にモーターとバッテリーが搭載されることは、新たな企業参入の機会を生みます。また、欧州の燃費規制や中国の新エネルギー車促進などの政策は、各国の取り組みとして自動車の電動化に向けた開発やハイブリッドや燃料電池を含む電動車両の普及を後押ししています。その結果、全体のバランスや最適化を進めるため、より多くの検証が必要となり、自動車会社の開発工数を大幅に肥大化させていく課題も顕在化してきました。HORIBA FuelCon GmbH(FuelCon)は、クリーンで高効率なエネルギー社会を目指し、業界のニーズをサポートしています。このセクションでは、FuelConが提供するバッテリーと燃料電池に関連する技術的な課題解決に向けたソリューションを紹介します。

Introduction

Due to the ongoing concern about the environment, the automotive industry is witnessing a multidimensional shift, focusing on three major challenge areas: Changing Market, Changing Technology and Changing Legislation. Addressing these challenges while keeping up with the decreasing development time demands an increasing amount of more complex and integrated, but at the same time efficient validation.

The whole industry is aligning itself to this major shift. Keeping with our culture of innovation and commitment to the environment we are supporting the industry needs in “Making the World Cleaner and More Efficient”. The changing market is driven by an increasing complexity and the need for faster development cycles.

These changes demand the industry to simultaneously work on multiple technologies, while increasing the need for a more complex but also more efficient validation. The automotive industry focuses a lot of effort onto the area of new propulsion technologies, especially on electrified solutions (xEV). Many of the necessary components currently lack the technological maturity and therefore require more validation. HORIBA FuelCon GmbH (FuelCon) is assisting them in overcoming the associated technical challenges through the application of our battery and fuel cell validation solutions.

This section introduces the battery and fuel cell verification solutions provided by FuelCon.

Yasunari HANAKI

花木 保成

Carsten Krüger

カーステン クルーガー

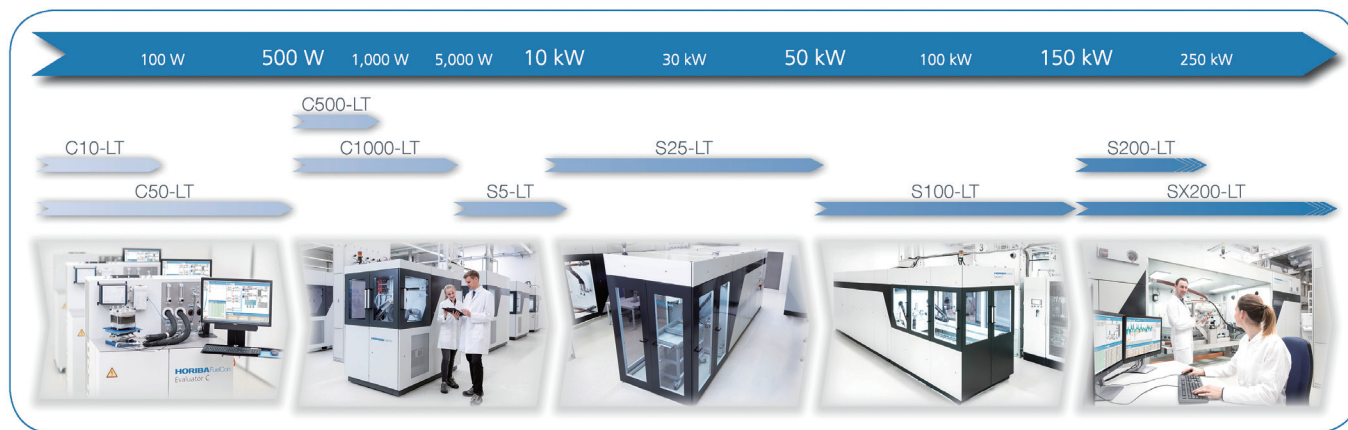

Figure1 Evaluator LT series

Evaluator LT for PEM*1 Fuel Cells

FuelCon's Evaluator LT test stations are proven solutions for our customers' specific requirements: long-term studies, performance tests, system qualification and material characterization. Our product line (Figure 1) ranges from test and diagnostic solutions for PEM and high temperature PEM single cells, components, stacks and systems to manufacturing equipment of PEM stacks.

*1: PEM: Polymer Electrolyte Membrane

The Evaluator LT test stations ensure efficient completion of automated test programs within a temperature range from -40°C up to 250°C (high temperature PEM) and a power range from 1 W up to 250+ kW. With several dynamic humidification options and system pressure levels they allow running any test program and load cycle characteristic for portable, stationary and mobile fuel cell applications. Their robust PLC system control guarantees the performance of life cycle tests, as well as a reproducible performance and the optimization of assembling processes - always with maximum safety for operators, laboratory and test item.

FuelCon exclusively focuses on test and diagnostic systems for fuel cells and energy converters. Particular internal processes and measures ensure that all your sensitive technical and commercial details are kept strictly confidential. Our TISAX certification guarantees maximum data security.

Evaluator HT for Solid Oxide Fuel Cell (SOFC)

FuelCon's Evaluator HT test stations are proven solutions for our customers' specific requirements: long-term studies, performance tests, system qualification and material characterization of SOFC single cells, components, stacks, hot boxes or complete systems. Our product line (Figure 2) ranges from test and diagnostic solutions to equipment for integrated manufacturing and quality management as well as sintering stations for assembling of SOFC stacks.

The Evaluator HT test stations ensure efficient operation of automated test programs and thermal cycles at temperatures up to 1,100°C. The systems can run in both fuel cell mode and electrolysis mode. Their robust PLC (Programmable Controller) system control guarantees the reproducible performance of life cycle tests as well as the optimization of assembling processes



Figure2 Evaluator HT series

- always with maximum safety for operators, laboratory and test item. For all Evaluator HT stations, proven furnace designs and various modules for reproducible, defined adjustment of single cells or stacks are available with various mixing options for the input gases to simulate any fuel cell scenario.

Classes

Different testing tasks require different testing systems. Therefore, FuelCon offers a complete product line of test system types designed to meet specific customer requirements.

FuelCon’s Evaluator C series on the one hand is specifically designed to characterize components such as interconnector plates, sealings, electrodes or membrane electrode assemblies (MEA: Membrane Electrode Assemblies), gas diffusion layers (GDL), bipolar plates, sealings, complete single cells.

The Evaluator S series on the other hand provides testing of stacks, hot boxes (for SOFC) and fuel cell systems.

End-of-Line (EOL) stations allow fast final testing in the production of stacks under fully reproducible gas compositions, temperatures, humidification as well as under precise electrical loading.

All stations are available to be upgraded for testing cells and stacks in electrolyzer mode simply adding some process parts and modifying the electronic load.

FuelCon’s sintering stations allow to produce stacks under fully reproducible gas compositions, temperature cycles as well as under precise mechanical compression.

Humidification Technologies

The humidification of the anode and cathode gas flows is an important duty in every fuel cell test station. It typically requires the highest effort among the process part of a test station and is the largest energy consumer within the station. Besides the process parts, the control system plays an important role to ensure a proper functionality.

Depending on the chosen humidification technology, FuelCon’s real-time control system guarantees a constant gas humidification within the specified flow

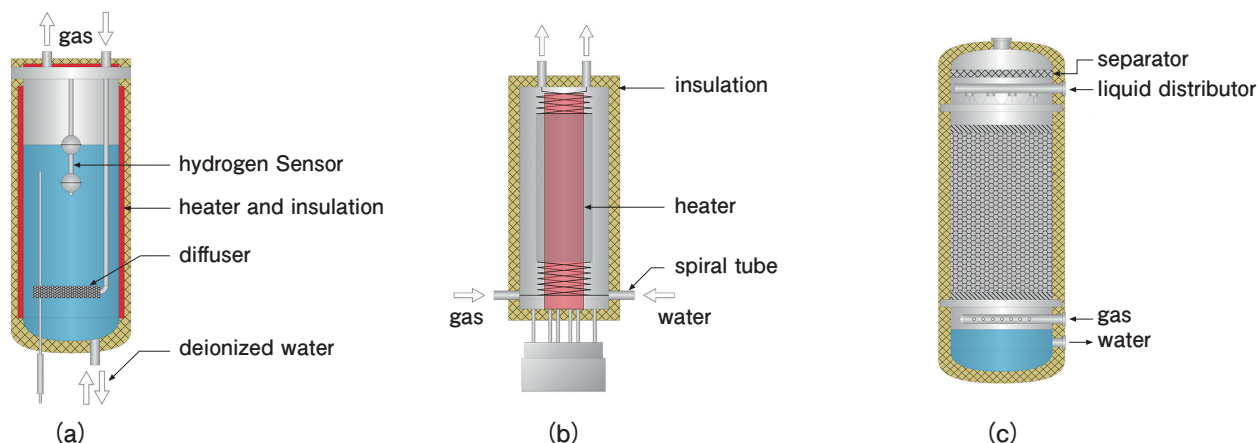

Figure 3 Humidification method;
 (a) bubbler method (dew point 25°C - 90°C, gas flow rate 0.1 - 200 NI/min, for stationary operation),
 (b) injection method (dew point -20°C - 150°C, gas flow rate 0.5 - 600 NI/min, for dynamic operation), and
 (c) shower method (dew point 25°C - 90°C, gas flow rate 200 - 15,000 NI/min, for dynamic operation).

temperature-pressure range of the test station. Especially during a dynamic operation, FuelCon's PLC based control system shows its strength developed over years at a large number of test stations. FuelCon supports customers to choose the right humidification system depending on your specific needs, in case of fuel cell technology, duty cycles, dynamic, accuracy and the characteristic flow pressure-temperature field.

The following technologies are available:

- Advanced Saturator: low to medium gas flow, stationary operation (Figure 3a)
- Direct Injection: medium to high gas flows, dynamic operation (Figure 3b)
- Counter-flow: high gas flow, dynamic or stationary operation(Figure 3c)

Each technology is equipped with dry gas bypasses and an automatic refill of de-ionized water. The operator can choose the desired physical property of the set point (dew point, relative humidity, water amount or steam / carbon ratio) by using the TestWork GUI.

Evaluator B for Batteries

The increased interest in electric mobility and energy storages results in a high demand for test engineering, for research and development as well as validation and qualification. For the development of powerful batteries and battery systems, recording characteristic curves, examining degradation, identifying the cycle stability, the SOC or the capacity are only some of the many necessary test tasks.

As an established manufacturer of automated test plants, HORIBA FuelCon offers, with the Evaluator B (Figure 4), a customer-specific concept that fulfills the ambitious demands of these applications delivering high precision and flexibility.

All Evaluator B systems possess a real-time level as well as a higher-level data management that is realized by means of a server-client architecture. The



Figure 4 Evaluator B

control is carried out through the user-friendly software TestWork. The open interface concept of the system furthermore enables simply integrating additional components as for instance CAN² bus interfaces, electronic control units, additional liquid cooling circuits, climate chambers or acquiring further temperature or voltage measurement values.

*2: CAN: Controller Area Network. Standard of robust internal communication network designed to allow microcontrollers and devices to communicate with each other in applications without a host computer.

Our test stations are applied in universities, test laboratories and research institutions as well as for the assembly of batteries and cells in the automotive branch.

Battery Emulator Technology TrueData X-OPS 48

The TrueData X-OPS 48 systems (Figure 5) are able to emulate the behavior of electrical energy storage systems up to 60 V both functionally and electrically. Therefore they are perfectly qualified for uses like motor test stations, electromotor test stations or 48 V component tests.

Due to the universal port concept, the devices are easy to actuate via CAN interface and consequently it is completely unproblematic to include them into preexisting test runs. Because of the compact construction, there is also a mobile version of the TrueData X-OPS 48 devices, which can be used comfortably with various test stations.

Currents up to ± 500 A are possible for the simulation of starter behaviors and start-stop scenarios. Higher currents and performances are also achievable due to parallel connection. In addition to constant modes of power, voltage, resistors and performance, it is even possible to set switching conditions and alarm boundaries.

The deposited simulation models permit the emulation of:

- Batteries, battery modules, battery packs and battery systems
- Fuel cells, fuel cell stacks and fuel cell systems
- 48 V on-board power supplies in vehicles

Individualized, time-discrete, time-continuous or hybrid simulink and state flow models can also be processed. TrueData X-OPS 48 is furthermore optionally applicable as a battery tester.

Software TestWork

TestWork (Figure 6) is FuelCon's intuitive software for the automated operation of test stations of the Evaluator product line. Tailored to the specific requirements of our customers, the software not only allows the operation of single test stations, but also enables the management of complete test fields. The graphical user interface has been developed in close consultation with our customers and respects the latest trends in software ergonomics. TestWork focusses on an intuitive operation and does not depend on the skills of the particular user.



Figure 5 TrueData X-OPS 48

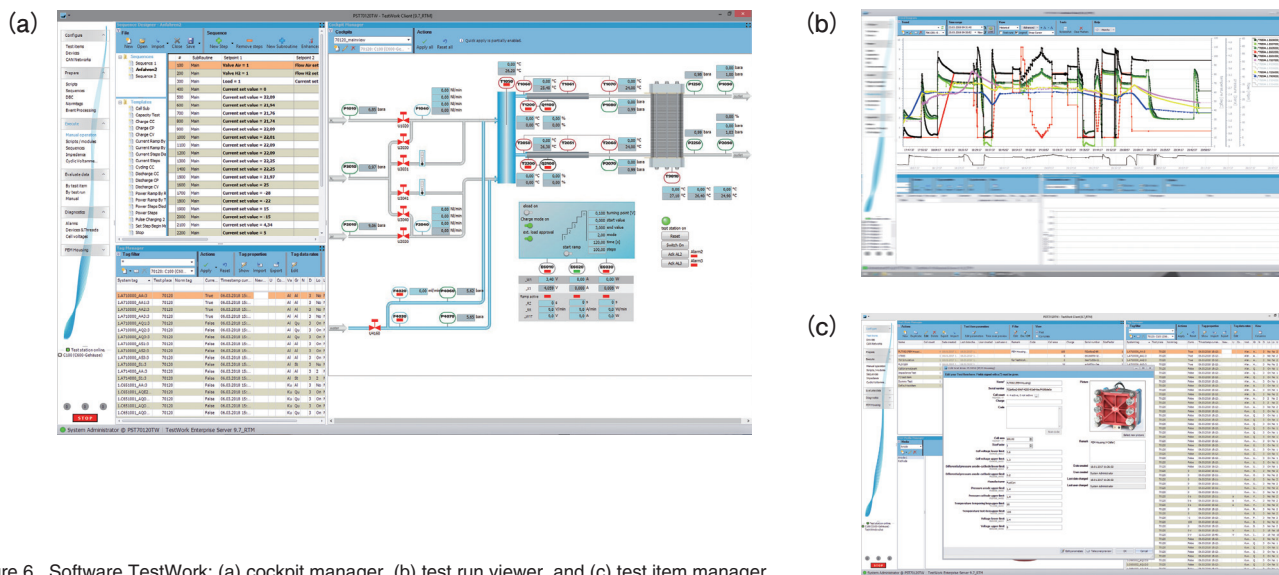

Figure 6 Software TestWork; (a) cockpit manager, (b) test run viewer, and (c) test item manager.

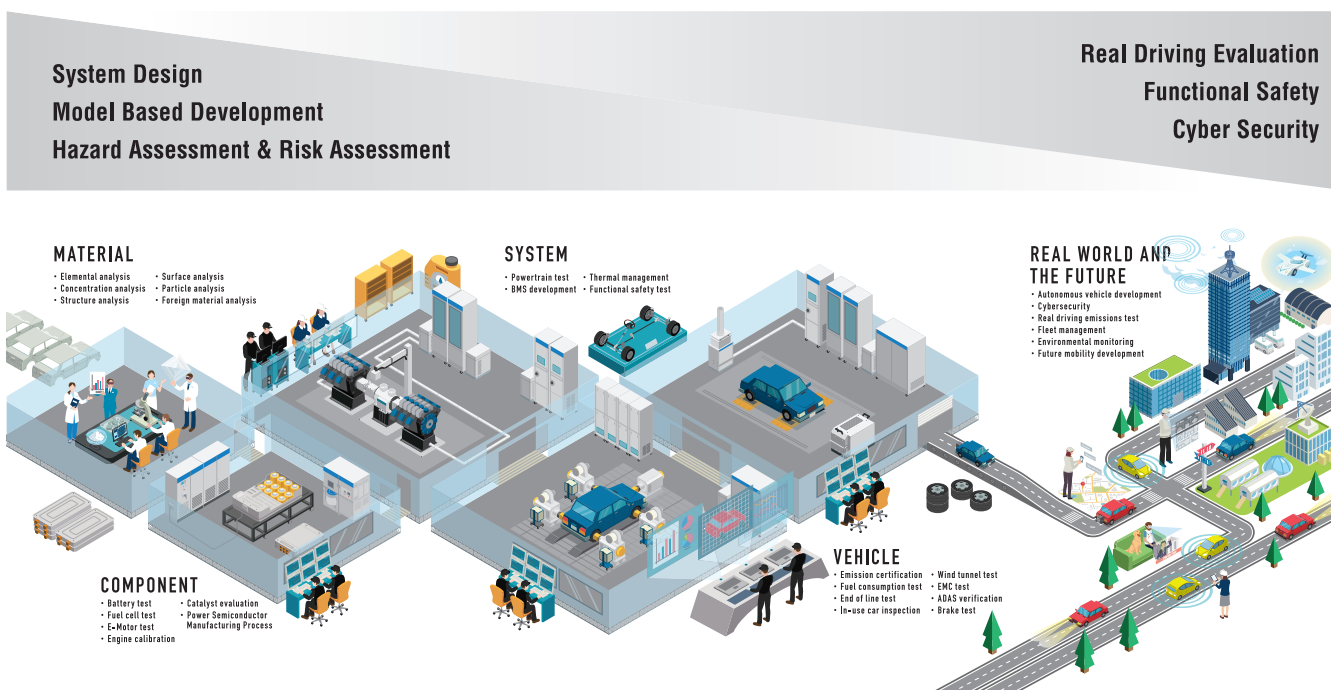

Figure 7 HORIBA front-loading testing system

Our Capability

As shown in Figure 7, “Measure” materials, components, systems, and the car itself in the lab, on the road, and in the simulation. And by automating “Measure”, “connecting” labs and laboratories, and “connecting” labs and actual roads through simulations, we support the efficiency, speed, and optimization of development processes and various tests for motorized vehicles. FuelCon will continue to be assisting them in overcoming the associated technical challenges through the application of our battery and fuel cell validation solutions.

* This content is based on our investigation at this publish unless otherwise stated.



Yasunari HANAKI

花木 保成

Manager, System Solution Dept.
Research & Development Division, HORIBA, Ltd.
株式会社 堀場製作所
開発本部 システムソリューション部
先行技術担当マネジャー



Carsten Krüger

カーステン クルーガー

Head of Marketing, Team Leader Marketing &
Administration
Sales Department
HORIBA FuelCon GmbH